

## Fiber Optic Matrix Switchers

### FOX Matrix 320x

### FOX Matrix 14400

Configurable Fiber Optic Digital Matrix Switchers



# Safety Instructions

## Safety Instructions • English

**WARNING:** This symbol, , when used on the product, is intended to alert the user of the presence of unisolated dangerous voltage within the product's enclosure that may present a risk of electric shock.

**ATTENTION:** This symbol, , when used on the product, is intended to alert the user of important operating and maintenance (servicing) instructions in the literature provided with the equipment.

For information on safety guidelines, regulatory compliances, EMI/EMF compatibility, accessibility, and related topics, see the Extron Safety and Regulatory Compliance Guide, part number 68-290-01, on the Extron website, [www.extron.com](http://www.extron.com).

## Sicherheitsanweisungen • Deutsch

**WARNUNG:** Dieses Symbol , auf dem Produkt soll den Benutzer darauf aufmerksam machen, dass im Inneren des Gehäuses dieses Produktes gefährliche Spannungen herrschen, die nicht isoliert sind und die einen elektrischen Schlag verursachen können.

**VORSICHT:** Dieses Symbol , auf dem Produkt soll dem Benutzer in der im Lieferumfang enthaltenen Dokumentation besonders wichtige Hinweise zur Bedienung und Wartung (Instandhaltung) geben.

Weitere Informationen über die Sicherheitsrichtlinien, Produkthandhabung, EMI/EMF-Kompatibilität, Zugänglichkeit und verwandte Themen finden Sie in den Extron-Richtlinien für Sicherheit und Handhabung (Artikelnummer 68-290-01) auf der Extron-Website, [www.extron.com](http://www.extron.com).

## Instrucciones de seguridad • Español

**ADVERTENCIA:** Este símbolo, , cuando se utiliza en el producto, avisa al usuario de la presencia de voltaje peligroso sin aislar dentro del producto, lo que puede representar un riesgo de descarga eléctrica.

**ATENCIÓN:** Este símbolo, , cuando se utiliza en el producto, avisa al usuario de la presencia de importantes instrucciones de uso y mantenimiento recogidas en la documentación proporcionada con el equipo.

Para obtener información sobre directrices de seguridad, cumplimiento de normativas, compatibilidad electromagnética, accesibilidad y temas relacionados, consulte la Guía de cumplimiento de normativas y seguridad de Extron, referencia 68-290-01, en el sitio Web de Extron, [www.extron.com](http://www.extron.com).

## Instructions de sécurité • Français

**AVERTISSEMENT :** Ce pictogramme, , lorsqu'il est utilisé sur le produit, signale à l'utilisateur la présence à l'intérieur du boîtier du produit d'une tension électrique dangereuse susceptible de provoquer un choc électrique.

**ATTENTION :** Ce pictogramme, , lorsqu'il est utilisé sur le produit, signale à l'utilisateur des instructions d'utilisation ou de maintenance importantes qui se trouvent dans la documentation fournie avec le matériel.

Pour en savoir plus sur les règles de sécurité, la conformité à la réglementation, la compatibilité EMI/EMF, l'accessibilité, et autres sujets connexes, lisez les informations de sécurité et de conformité Extron, réf. 68-290-01, sur le site Extron, [www.extron.com](http://www.extron.com).

## Istruzioni di sicurezza • Italiano

**AVVERTENZA:** Il simbolo, , se usato sul prodotto, serve ad avvertire l'utente della presenza di tensione non isolata pericolosa all'interno del contenitore del prodotto che può costituire un rischio di scosse elettriche.

**ATTENZIONE:** Il simbolo, , se usato sul prodotto, serve ad avvertire l'utente della presenza di importanti istruzioni di funzionamento e manutenzione nella documentazione fornita con l'apparecchio.

Per informazioni su parametri di sicurezza, conformità alle normative, compatibilità EMI/EMF, accessibilità e argomenti simili, fare riferimento alla Guida alla conformità normativa e di sicurezza di Extron, cod. articolo 68-290-01, sul sito web di Extron, [www.extron.com](http://www.extron.com).

## Instrukcje bezpieczeństwa • Polska

**OSTRZEŻENIE:** Ten symbol, , gdy używany na produkt, ma na celu poinformować użytkownika o obecności izolowanego i niebezpiecznego napięcia wewnątrz obudowy produktu, który może stanowić zagrożenie porażenia prądem elektrycznym.

**UWAGI:** Ten symbol, , gdy używany na produkt, jest przeznaczony do ostrzegania użytkownika ważne operacyjne oraz instrukcje konserwacji (obsługi) w literaturze, wyposażone w sprzęt.

Informacji na temat wytycznych w sprawie bezpieczeństwa, regulacji wzajemnej zgodności, zgodność EMI/EMF, dostępności i Tematy pokrewne, zobacz Extron bezpieczeństwa i regulacyjnego zgodności przewodnik, część numer 68-290-01, na stronie internetowej Extron, [www.extron.com](http://www.extron.com).

## Инструкция по технике безопасности • Русский

**ПРЕДУПРЕЖДЕНИЕ:** Данный символ, , если указан на продукте, предупреждает пользователя о наличии неизолированного опасного напряжения внутри корпуса продукта, которое может привести к поражению электрическим током.

**ВНИМАНИЕ:** Данный символ, , если указан на продукте, предупреждает пользователя о наличии важных инструкций по эксплуатации и обслуживанию в руководстве, прилагаемом к данному оборудованию.

Для получения информации о правилах техники безопасности, соблюдении нормативных требований, электромагнитной совместимости (ЭМП/ЭДС), возможности доступа и других вопросах см. руководство по безопасности и соблюдению нормативных требований Extron на сайте Extron: , [www.extron.com](http://www.extron.com), номер по каталогу - 68-290-01.

## 安全说明 • 简体中文

**警告:** 产品上的这个标志意在警告用户该产品机壳内有暴露的危险电压, 有触电危险。

**注意:** 产品上的这个标志意在提示用户设备随附的用户手册中有重要的操作和维护(维修)说明。

关于我们产品的安全指南、遵循的规范、EMI/EMF 的兼容性、无障碍使用的特性等相关内容, 敬请访问 Extron 网站, [www.extron.com](http://www.extron.com), 参见 Extron 安全规范指南, 产品编号 68-290-01。

## 安全記事・繁體中文

**警告:** ⚠️ 若產品上使用此符號, 是為了提醒使用者, 產品機殼內存在著可能會導致觸電之風險的未絕緣危險電壓。

**注意:** ⚠️ 若產品上使用此符號, 是為了提醒使用者, 設備隨附的用戶手冊中有重要的操作和維護(維修)說明。

有關安全性指導方針、法規遵守、EMI/EMF 相容性、存取範圍和相關主題的詳細資訊, 請瀏覽 Extron 網站: [www.extron.com](http://www.extron.com), 然後參閱《Extron 安全性與法規遵守手冊》, 準則編號 68-290-01。

## 安全上のご注意・日本語

**警告:** この記号 ⚠️ が製品上に表示されている場合は、筐体内に絶縁されていない高電圧が流れ、感電の危険があることを示しています。

**注意:** この記号 ⚠️ が製品上に表示されている場合は、本機の取扱説明書に記載されている重要な操作と保守(整備)の指示についてユーザーの注意を喚起するものです。

安全上のご注意、法規遵守、EMI/EMF適合性、その他の関連項目については、エクストロンのウェブサイト [www.extron.com](http://www.extron.com) より『Extron Safety and Regulatory Compliance Guide』(P/N 68-290-01) をご覧ください。

## 안전 지침 · 한국어

**경고:** 이 기호 ⚠️ 가 제품에 사용될 경우, 제품의 인클로저 내에 있는 접지되지 않은 위험한 전류로 인해 사용자가 감전될 위험이 있음을 경고합니다.

**주의:** 이 기호 ⚠️ 가 제품에 사용될 경우, 장비와 함께 제공된 책자에 나와 있는 주요 운영 및 유지보수(정비) 지침을 경고합니다.

안전 가이드라인, 규제 준수, EMI/EMF 호환성, 접근성, 그리고 관련 항목에 대한 자세한 내용은 Extron 웹 사이트([www.extron.com](http://www.extron.com))의 Extron 안전 및 규제 준수 안내서, 68-290-01 조항을 참조하십시오.

## Copyright

© 2008-2019 Extron Electronics. All rights reserved.

## Trademarks

All trademarks mentioned in this guide are the properties of their respective owners.

The following registered trademarks<sup>(®)</sup>, registered service marks<sup>(SM)</sup>, and trademarks<sup>(TM)</sup> are the property of RGB Systems, Inc. or Extron Electronics (see the current list of trademarks on the [Terms of Use](#) page at [www.extron.com](http://www.extron.com)):

### Registered Trademarks<sup>(®)</sup>

Extron, Cable Cubby, Codec Connect, ControlScript, CrossPoint, DTP, eBUS, EDID Manager, EDID Minder, Flat Field, FlexOS, Global Configurator, Global Scriptor, GlobalViewer, Hideaway, IP Intercom, IP Link, Key Minder, LinkLicense, LockIt, MediaLink, MediaPort, NetPA, PlenumVault, PoleVault, PowerCage, PURE3, Quantum, SoundField, SpeedMount, SpeedSwitch, System *INTEGRATOR*, TeamWork, TouchLink, V-Lock, VN-Matrix, VoiceLift, WallVault, WindoWall, XTP, and XTP Systems

**Registered Service Mark<sup>(SM)</sup>:** S3 Service Support Solutions

### Trademarks<sup>(TM)</sup>

AAP, AFL (Accu-Rate Frame Lock), ADSP (Advanced Digital Sync Processing), Auto-Image, CableCover, CDRS (Class D Ripple Suppression), DDSP (Digital Display Sync Processing), DMI (Dynamic Motion Interpolation), Driver Configurator, DSP Configurator, DSVP (Digital Sync Validation Processing), eLink, EQIP, EverLast, FastBite, FOX, FOXBOX, HyperLane, IP Intercom HelpDesk, MAAp, MicroDigital, Opti-Torque, ProDSP, QS-FPC (QuickSwitch Front Panel Controller), Room Agent, Scope-Trigger, ShareLink, Show Me, SIS, Simple Instruction Set, Skew-Free, SpeedNav, StudioStation, Triple-Action Switching, True4K, Vector<sup>(TM)</sup> 4K, VideoLounge, WebShare, XTRA, ZipCaddy, and ZipClip

## FCC Class A Notice

This equipment has been tested and found to comply with the limits for a Class A digital device, pursuant to part 15 of the FCC rules. The Class A limits provide reasonable protection against harmful interference when the equipment is operated in a commercial environment. This equipment generates, uses, and can radiate radio frequency energy and, if not installed and used in accordance with the instruction manual, may cause harmful interference to radio communications. Operation of this equipment in a residential area is likely to cause interference. This interference must be corrected at the expense of the user.

**NOTE:** For more information on safety guidelines, regulatory compliances, EMI/EMF compatibility, accessibility, and related topics, see the “**Extron Safety and Regulatory Compliance Guide**” on the Extron website.

## Battery Notice

This product contains a battery. **Do not open the unit to replace the battery.** If the battery needs replacing, return the entire unit to Extron (for the correct address, see the Extron Warranty section on the last page of this guide).

**CAUTION:** Risk of explosion. Do not replace the battery with an incorrect type. Dispose of used batteries according to the instructions.

**ATTENTION :** Risque d’explosion. Ne pas remplacer la pile par le mauvais type de pile. Débarrassez-vous des piles usagées selon le mode d’emploi.

## Class 1 Laser Product

Any service to this product must be carried out by Extron Electronics and its qualified service personnel.

**CAUTION:** Using controls, making adjustments, or performing procedures in a manner other than what is specified herein may result in hazardous radiation exposure.

**NOTE:** For more information on safety guidelines, regulatory compliances, EMI/EMF compatibility, accessibility, and related topics, see the “**Extron Safety and Regulatory Compliance Guide**” on the Extron website.

## Produit laser de classe 1

Si ce produit a besoin d’un quelconque entretien, celui-ci doit être fait par Extron Electronics et son personnel qualifié.

**ATTENTION :** L’utilisation de commandes, la réalisation de réglages, ou l’exécution de procédures de manière contraire aux dispositions établies dans le présent document, présente un risque d’exposition dangereuse aux radiations.

**Remarque :** Pour plus d’informations sur les directives de sécurité, les conformités de réglementation, la compatibilité EMI/EMF, l’accessibilité, et les sujets en lien, consultez le « **Informations de sécurité et de conformité Extron** » sur le site internet d’Extron.

## Conventions Used in this Guide

### Notifications

The following notifications are used:

 **WARNING:** Potential risk of severe injury or death.  
**AVERTISSEMENT :** Risque potentiel de blessure grave ou de mort.

**CAUTION:** Risk of minor personal injury.  
**ATTENTION :** Risque de blessure mineure.

**ATTENTION:**

- Risk of property damage.
- Risque de dommages matériels.

**NOTE:** A note draws attention to important information.

**TIP:** A tip provides a suggestion to make working with the application easier.

### Software Commands

Commands are written in the fonts shown here:

```
^ARMerge Scene , ,Op1 scene 1,1 ^B51 ^W^C  
[Ø1] RØØØ4 ØØ3ØØ ØØ4ØØ ØØ8ØØ ØØ6ØØ [Ø2] 35 [17] [Ø3]
```

```
Esc[X13 *X18* X26* X29* X27]CE ←
```

**NOTE:** For commands and examples of computer or device responses mentioned in this guide, the character “Ø” is used for the number zero and “O” represents the capital letter “o.”

Computer responses and directory paths that do not have variables are written in the font shown here:

```
Reply from 2Ø8.132.18Ø.48: bytes=32 times=2ms TTL=32  
C:\Program Files\Extron
```

Variables are written in slanted form as shown here:

```
ping xxx.xxx.xxx.xxx -t  
SOH R Data STX Command ETB ETX
```

Selectable items, such as menu names, menu options, buttons, tabs, and field names are written in the font shown here:

```
From the File menu, select New.  
Click the OK button.
```

## Specifications Availability

Product specification are available on the Extron website, [www.extron.com](http://www.extron.com).

## Extron Glossary of Terms

A glossary of terms is available at <http://www.extron.com/technology/glossary.aspx>.

# Contents

---

## **Introduction..... 1**

About this Guide.....	1
About the FOX Matrix Switchers .....	1
Fiber Cable Transmission Modes .....	4
Definitions.....	4
Features .....	4

---

## **Installation..... 7**

Setup and Installation Checklist .....	7
Get Ready .....	7
Configure the Matrix Switcher .....	7
Perform Physical Installation .....	7
Install Software .....	7
Rear Panel Boards, Cabling, and Features.....	8
I/O Boards.....	10
Remote Port.....	13
Ethernet Connection.....	14
Reset Button and LED.....	15
Power Supply Modules and Indicator LEDs ..	15
Cooling Fan Assemblies.....	15
Front Panel Features.....	16
Reset Operations.....	18
Performing Soft System Resets (Resets 3, 4, and 5) .....	19

---

## **Programming Guide..... 20**

Host Control Ports.....	20
Serial Ports .....	20
Ethernet (LAN) Port.....	21
Host-to-Switcher Instructions .....	22
Switcher-initiated Messages .....	22
Switcher Error Responses .....	23
Using the Command and Response Tables .....	23
Command and Response Table for SIS Commands .....	24
Command and Response Table for IP- and SNMP-Specific SIS Commands .....	32
Special Characters .....	35

---

## **Matrix Software..... 36**

About this Program .....	36
Software Operation via Ethernet .....	36
Software Operation via a Serial Port.....	37
Installing the Software.....	37
Using the Matrix Switchers Control Program.....	40
Starting the Program .....	40
IP Settings / Options Dialog Box.....	43
Updating Firmware .....	48
Uploading HTML Files.....	51
Windows Buttons, List Boxes, and Trash Can.....	52
Windows Menus.....	52
Using Emulation Mode.....	56
Using the Help System .....	57

---

## **HTML Operation ..... 58**

Opening the Embedded Web Pages.....	59
Status Tab .....	60
System Status Page .....	60
Input Link Page.....	61
Configuration Tab .....	62
System Settings Page .....	62
Passwords Page.....	65
Email Settings Page.....	66
SNMP Settings Page .....	68
Firmware Upgrade Page.....	70
File Management Tab .....	71
File Management Page .....	71
Control Tab.....	72
Set and View Ties Page.....	72

---

**Maintenance and Modifications ..... 74**

Mounting the Switcher.....	74
UL Guidelines .....	74
Mounting Instructions .....	75
Battery and Power Precautions .....	75
Removing and Installing an I/O Board or Blank Panel .....	75
Removing an I/O Board or Blank Panel.....	77
Installing an I/O Board or Blank Panel.....	77
Removing and Installing a Power Supply Module.....	78
Removing a Power Supply Module .....	78
Installing a Power Supply Module .....	79
Removing and Installing a Fan Module.....	80
Removing a Fan Module .....	80
Installing a Fan Module .....	81

---

**Ethernet Connection ..... 82**

Ethernet Link.....	82
Ethernet Connection.....	82
Default IP Address.....	82
Pinging to Determine the Extron IP Address.....	83
Pinging to Determine the Web IP Address.....	83
Configuring the Switcher for Network Use via the ARP Command .....	84
Connecting as a Telnet Client.....	85
Telnet Tips .....	86
Subnetting — A Primer.....	87
Gateways .....	87
Local and Remote Devices .....	87
IP Addresses and Octets .....	88
Subnet Masks and Octets .....	88
Determining Whether Devices Are on the Same Subnet.....	88

# Introduction

**⚠ WARNING:** The FOX matrix switcher outputs continuous invisible light (Class 1 rated), which may be harmful to the eyes; use with caution.

**AVERTISSEMENT :** Le grilles de commutation de la gamme FOX émet une lumière invisible en continu (conforme à la classe 1) qui peut être dangereux pour les yeux, à utiliser avec précaution.

- Do not look into the rear panel fiber optic cable connectors or into the fiber optic cables themselves.
- Ne regardez pas dans les connecteurs de câble fibre optique sur le panneau arrière ou dans les câbles fibre optique eux-mêmes.
- Plug the attached dust cap into the optical transceiver when the fiber optic cable is unplugged.
- Branchez la protection contre la poussière dans l'ensemble émetteur/récepteur lorsque le câble fibre optique est débranché.

- [About this Guide](#)
- [About the FOX Matrix Switchers](#)
- [Definitions](#)
- [Features](#)

## About this Guide

This guide contains installation, configuration, and operating information for the Extron FOX Matrix 320x Switcher and FOX Matrix 14400 Switcher. These customizable matrix switchers support up to 320 (FOX Matrix 320x) or 144 (FOX Matrix 14400) inputs and outputs.

**NOTE:** In this guide, “FOX matrix switcher” and “switcher” refer to either switcher model unless otherwise specified.

## About the FOX Matrix Switchers

The FOX matrix switchers (see [figure 1](#) on the next page for a FOX Matrix 14400 example) distribute optical and electronic input signals to one or more optical and electronic outputs. The matrix switchers can route multiple input and output configurations simultaneously. The switchers are configurable, assembled from individual input/output (I/O) boards, each of which supports 16 inputs by 16 outputs in a combination of the following types of board:

- **Singlemode and multimode fiber optic 16x16 I/O boards** — These non-pathologically compliant fiber optic boards route signals that are compatible with all Extron FOX 500, FOXBOX, and PowerCage FOX fiber optic product lines.

- **FOX 3G I/O 1616 SM P board** (available for FOX Matrix 14400 only) — This pathologically-compliant fiber optic board passes digital signals in broadcasting applications, while addressing the compatibility issues of passing pathological signals generated from 3G-SDI, HD-SDI, and SDI signals over fiber optic systems, including those defined by the RP 178 and RP 198 standards.

**NOTE:** This board is not available for the FOX Matrix 320x.

- **BNC 3G/HD/SD-SDI 16x16 I/O board** — This pathologically-compliant board supports and passes 3G-SDI, HD-SDI, and SD-SDI signals in their native (electronic) format.

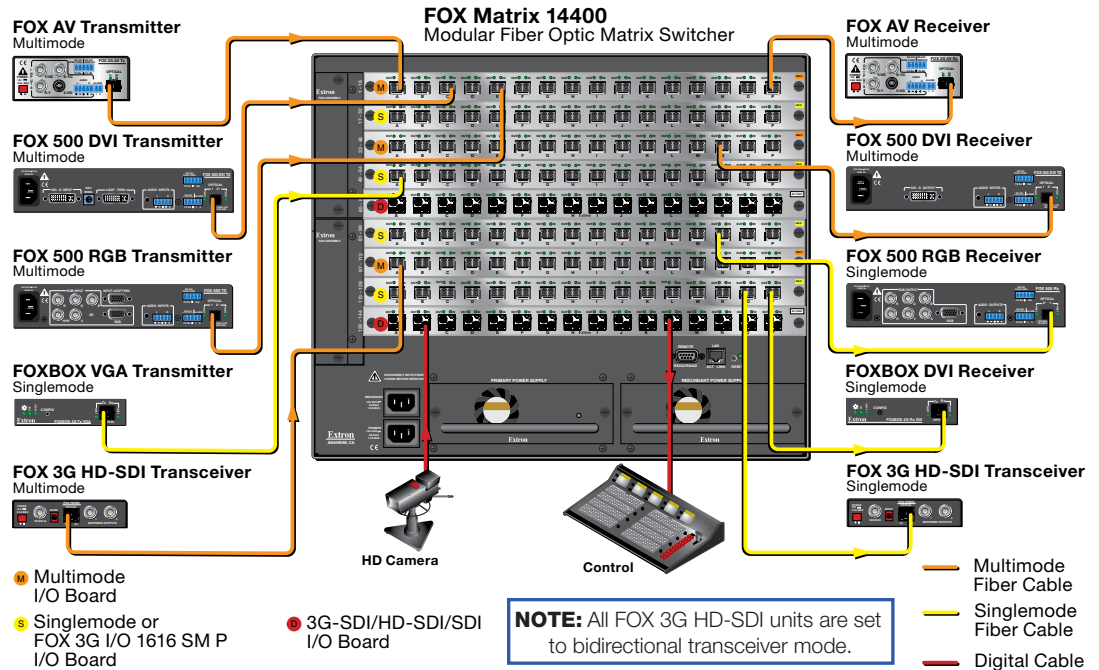

**Figure 1. Typical FOX Matrix 14400 Application**

**NOTE:** The non-pathologically compliant multimode and singlemode fiber optic I/O boards are physically and functionally identical, with the exception of the effective range of transmission. In this guide, any reference to fiber optic transmission applies to either transmission mode unless otherwise specified. The pathologically-compliant fiber optic I/O board is identified separately in this guide where appropriate.

By adding or removing I/O boards, the FOX matrix switcher is expandable and contractable within the following ranges:

- **FOX Matrix 320x** — Includes up to 20 I/O boards. It is expandable from a 16-input by 16-output matrix to a 320-input by 320-output matrix.
- **FOX Matrix 14400** — Includes up to 9 I/O boards. It is expandable from a 16-input by 16-output matrix to a 144-input by 144-output matrix.

The Extron proprietary fiber optic signal, generated by FOX 500, FOXBOX, PowerCage FOX, and FOX II transmitters, can include video, stereo audio, and transmitter-to-receiver RS-232 serial communications. The video component of the signal can be of a variety of formats, depending on the transmitter and receiver:

- RGB video
- Digital Visual Interface (DVI) video
- 3G-SDI, HD-SDI, or SDI video
- Low resolution (composite video or S-video)

**NOTES:**

- Compatible optical signals are digital signals from 270 Mbps through 4.25 Gbps that are sent and received via fiber optic small form factor pluggable (SFP) modules with LC-type connectors. The FOX matrix switchers support all compatible optical signals, whether transmitted or received by an Extron fiber optic system component or not.
- The FOX 500, FOXBOX, and PowerCage FOX transmitter-to-receiver communications, including the serial link, occupy one matrix switcher input and output. This matrix switcher also supports the FOX 500 return (receiver-to-transmitter) serial communications, but returning this signal stream to the transmitter occupies a separate matrix switcher input and output.

The matrix switchers input and output the optical signals that they route on fiber optic transceiver modules and the 3G-SDI, HD-SDI, and SDI video signals on BNC connectors.

The switcher has four (FOX Matrix 320x) or two (FOX Matrix 14400) internal, hot-swappable, 100 VAC to 240 VAC, 50-60 Hz, 400-watt power supplies that provide worldwide power compatibility and reliability.

The matrix switcher is a single box solution to complex fiber optic and broadcast signal routing applications. Each input and output is individually isolated and buffered. Any input can be switched to any one output or all outputs with virtually no crosstalk or signal noise between channels.

The matrix switcher can be remotely controlled using either the Extron Matrix Switchers Control Program or the Simple Instruction Set (SIS) (see **Programming Guide** on page 20). Control is available via the:

- Rear panel Remote RS232/RS422 port
- Rear panel LAN port
- Front panel RS-232 serial Config (configuration) port

The SIS is a set of basic ASCII code commands that provide simple control through a control system or PC without the need to enter long strings of code. SIS commands can be entered via any of the ports listed above.

The switcher can be operated remotely by any of the following connected to a serial port or LAN port:

- Control system
- PC computer
- Extron FPC 6000 Front Panel Controller for FOX Matrix 320x and FOX Matrix 14400
- Extron MKP 2000 remote control panel
- Extron MKP 3000 remote control panel
- **(RS-232 or RS-422 only)** Extron MCP 1000 remote control panel, an MKP 1000 remote keypad, or both

The matrix switcher is housed in a rack-mountable, metal enclosure with mounting flanges for standard 19-inch racks. The sizes are as follows:

- **FOX Matrix 320x** — 17U high
- **FOX Matrix 14400** — 9U high

## Fiber Cable Transmission Modes

Two versions of the non-pathologically compliant FOX matrix switcher fiber optic I/O board are documented in this guide. They are categorized by the type of fiber optic cable, multimode or singlemode, which defines the effective range of transmission:

- **Multimode** — Long distance, up to 300 m (985 feet)
- **Singlemode** — Very long distance, up to 30 km (18.75 miles)

### NOTES:

- All transceiver modules on a fiber optic I/O board, as delivered from Extron, are configured the same: either all multimode or all singlemode.
- You can mix multimode and singlemode fiber optic I/O boards in a FOX matrix switcher, but ensure that you connect the proper transmission mode fiber cables to the board.

## Definitions

The following terms, which apply to all Extron matrix switchers, are used throughout this guide:

- **Tie** — An input-to-output connection.
- **Set of ties** — An input tied to two or more outputs. (An output can never be tied to more than one input.)
- **Configuration** — One or more ties or one or more sets of ties.
- **Current configuration** — The configuration that is currently active in the switcher (also called “configuration 0”).
- **Global memory preset** — A configuration that has been stored. Up to 64 global presets can be stored in memory. When a preset is retrieved from memory, it becomes the current configuration. Presets can be saved and recalled via any of the serial ports or the LAN port.
- **Room** — A subset of outputs that are logically related to each other, as determined by the operator. The switchers support up to 10 rooms, each of which can consist of from 1 to 16 outputs.
- **Room memory preset** — A configuration that has been stored that consists of outputs in a single room. When a room preset is retrieved from memory, it becomes the current configuration. Up to 10 room presets can be associated with a room.

## Features

- **Fiber optic inputs and outputs** — With fiber optic I/O boards, the switchers input and output fiber optic signals on SFP optical connectors. The fiber optic I/O boards support digital signals from 270 Mbs through 4.25 Gbps.
- **SDI, HD-SDI, or 3G-SDI inputs and outputs** — With 3G/SDI/HD-SDI I/O boards, the switchers input and output SDI and HD-SDI signals on BNC connectors. The 3G/SDI/HD-SDI I/O boards support multi-rate SDI at rates up to 2.97 Gbps, and comply with SMPTE 259M-C, 292M, 424M, and ITU digital video standards.
- **Cross-format compatibility** —
  - An input on an 3G/SDI/HD-SDI I/O board can be tied to an output on a fiber optic I/O board or another 3G/SDI/HD-SDI I/O board.
  - An input on a fiber optic I/O board can be tied to an output on an 3G/SDI/HD-SDI I/O board or another fiber optic I/O board.

- **Switching flexibility** — The switcher provides individually buffered, independent matrix switched outputs.
  - **Any input can be tied to any or all outputs.**
  - **Quick multiple tie** — Multiple inputs can be switched to multiple outputs simultaneously. This allows all displays (outputs) to change from source to source at the same time.
- **Input link detection** — In critical environments or unmanned, remote locations, it may be vital to know that sources are active and switching. The switcher confirms that input sources are active by detecting light. Link detection provides instantaneous feedback via the serial ports of the switchers or local-area network (LAN) port. The input information can be displayed on any control system or in a control program on a LAN or Internet (IP) connection.
- **Rooming** — The switcher can be programmed to group multiple outputs to specific “rooms,” allowing them to have their own presets.
- **Operational reliability** — The FOX matrix switcher can support round-the-clock operation in mission-critical applications, using a combination of hot-swappable components and redundant power supplies.
  - **Field upgradable, hot-swappable modular design** — You can repair, upgrade, reconfigure, or expand the matrix by simply installing a new I/O board or replacing a board of one type with one of another. Hot-swappable components let you replace any I/O board at any time without powering down the switcher.
  - **Primary and redundant, hot-swappable power supplies** — The hot-swappable, externally accessible redundant power supply is configured to automatically take over the load from the primary supply in the case of a failure.

The complete power circuit, from the plug, through the power supply, to the insertion of the power onto the power distribution plane, is separate and redundant (see figure 2). If the installation includes uninterruptible or completely separate power sources, the switcher remains powered up through any power interruption except a simultaneous loss of power on both power sources.

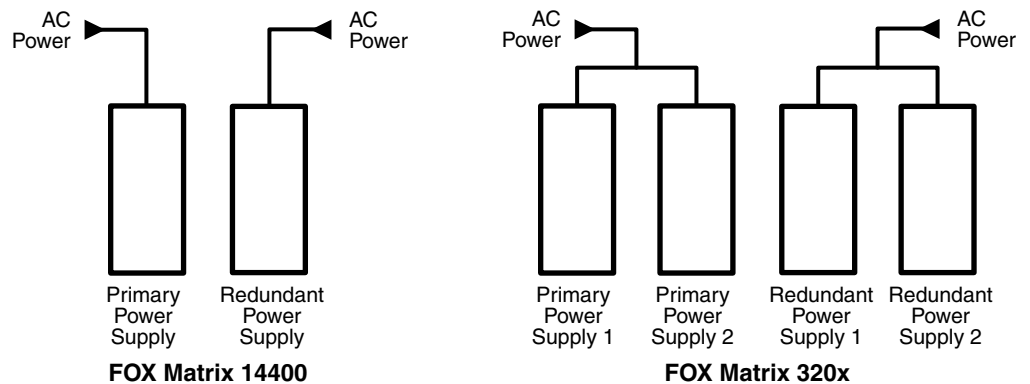

**Figure 2. Redundant Power Supply Backs Up Primary**

The hot-swappable redundant power supply means no downtime for the switcher and no loss of functionality should one power supply fail. Should a primary power supply fail, the redundant power supply immediately assumes the load of the failed primary supply. A failed power supply is easily replaceable from the rear at any time without powering down the matrix and with no tools required.

- **Ease of maintenance** — A failed power supply can be easily replaceable from the rear at any time without powering down the matrix, and with no tools required.
- **Power supply status LEDs** — Front panel and rear panel LEDs indicate the status of the primary and redundant power supplies.

- **Hot-swappable fans** — The hot-swappable, externally accessible fans allow quick replacement to avert overheating in the case of a failure. Fans can be replaced without powering down the switcher.
- **Operational flexibility** — Operations such as input and output selection and setting of presets can be performed via the Ethernet port or either serial port. The serial ports allow remote control via a PC or a control system. The Ethernet link allows multiple remote links with two levels of password protection. Remotely control the matrix switcher using one or more of the following:
  - Windows®-based Matrix Switchers Control Program
  - Simple Instruction Set (SIS)
  - Remote control panels and keypads
- **SNMP support for remote monitoring** — Supports the Simple Network Management Protocol (SNMP) internet-standard protocol, allowing IT personnel to manage devices on the IP network.
- **Laser controls** — Non-pathologically compliant fiber optic boards can be set, via SIS commands, to individually or globally disable the output laser drivers so that a driver does not output light. They can also be set, individually or globally, to automatic so that a driver turns on when a tie is made involving that driver or off when no tie is made.
- **Upgradeable firmware** — The firmware that controls all switcher operation can be upgraded in the field via either serial port or the Ethernet port, without taking the switcher out of service. Firmware upgrades are available for download at [www.extron.com](http://www.extron.com), and can be installed using the Matrix Switchers Control Program or the embedded HTML pages.
- **Global memory presets** — 64 global memory presets are a time-saving feature that lets you set up and store input/output configurations in advance. You can then recall those configurations when needed, with a few simple steps, via serial port or Ethernet control.
- **Rack mounting** — Rack mountable in any conventional 19-inch wide rack.
- **Permanent, rechargeable battery** — The matrix switcher has a rechargeable lithium battery to track time of day when power is disconnected.

 **WARNING:** There is a danger of explosion if the battery is incorrectly replaced. Replace it only with the same or equivalent type recommended by the manufacturer. Dispose of used batteries according to the instructions of the manufacturer.

**AVERTISSEMENT :** Si la pile est mal remplacée, il y a un risque d'explosion. Remplacez la batterie seulement avec le même type ou un type similaire de pile, recommandé par le fabricant. Débarrassez-vous des piles utilisées selon les instructions du fabricant.

**ATTENTION:**

- Non-Extron personnel must not attempt to remove the battery. Doing so voids the warranty.
- Du personnel ne faisant pas partie d'Extron ne doit pas essayer de retirer la batterie. Cela annulerait la garantie.

# Installation

This section details the installation and configuration of the FOX matrix switchers, including:

- [Setup and Installation Checklist](#)
- [Rear Panel Boards, Cabling, and Features](#)
- [Front Panel Features](#)
- [Reset Operations](#)

## Setup and Installation Checklist

### Get Ready

- Familiarize yourself with the matrix switcher.
- Obtain IP setting information for the matrix switcher from the local network administrator (see [Ethernet Connection](#), beginning on page 82).

### Configure the Matrix Switcher

- Install the desired I/O boards (see [Removing and Installing an I/O Board or Blank Panel](#) on page 75).

### Perform Physical Installation

- If desired, install the switcher in a rack (see [Mounting the Switcher](#) on page 74).
- Cable input and output devices to the I/O ports (see [I/O boards](#) on page 10).
- As desired, connect computers, control systems, or both to the rear panel Remote port (see [Remote Port](#) on page 13), LAN port (see [Ethernet Connection](#) on page 14), and front panel Configuration port (see [Front Panel Features](#) on page 16).
- Connect power (see [Power Supply Modules and Indicator LEDs](#) on page 15).
- Test the switcher by creating a tie (see the [Create ties](#) SIS commands on page 25).

### Install Software

- Install the Matrix Switchers Control Program (see [Installing the Software](#) on page 37).

## Rear Panel Boards, Cabling, and Features

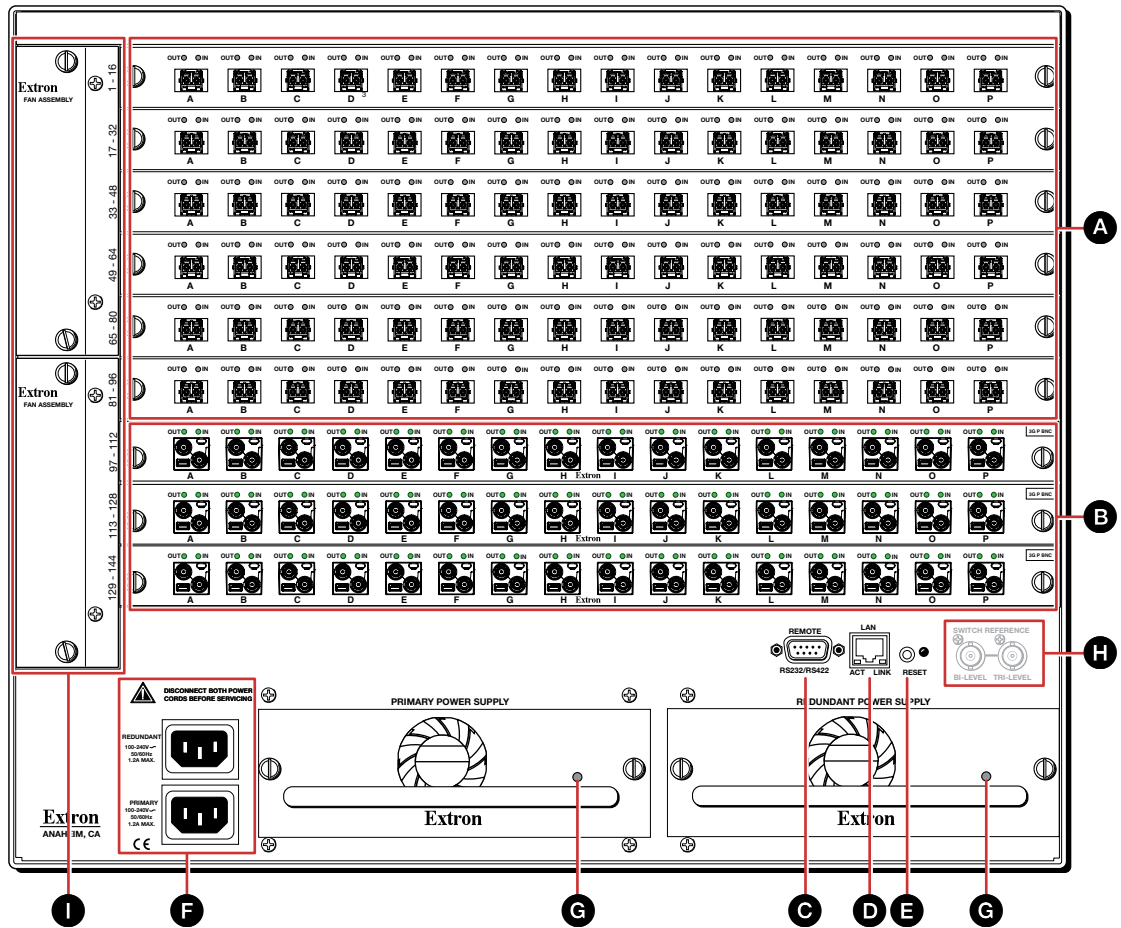

**Figure 3. FOX Matrix 14400 Switcher Rear Panel**

- A** Fiber optic boards with connectors and LEDs (see page 11)
- B** 3G-SDI, HD-SDI, and SDI boards with connectors and LEDs (see page 12)
- C** Remote RS232/RS422 port (see page 13)
- D** LAN connector (Ethernet connection) (see page 14)
- E** Reset button and LED (see page 15)
- F** Primary and Redundant AC power connectors (see page 15)
- G** Power supply modules and indicator LEDs (see page 15)
- H** Switch Reference BNCs — Present but not used on the FOX Matrix 14400.  
Not present on the FOX Matrix 320x.
- I** Cooling fan assemblies (see [Removing and Installing a Fan Module](#) on page 80)

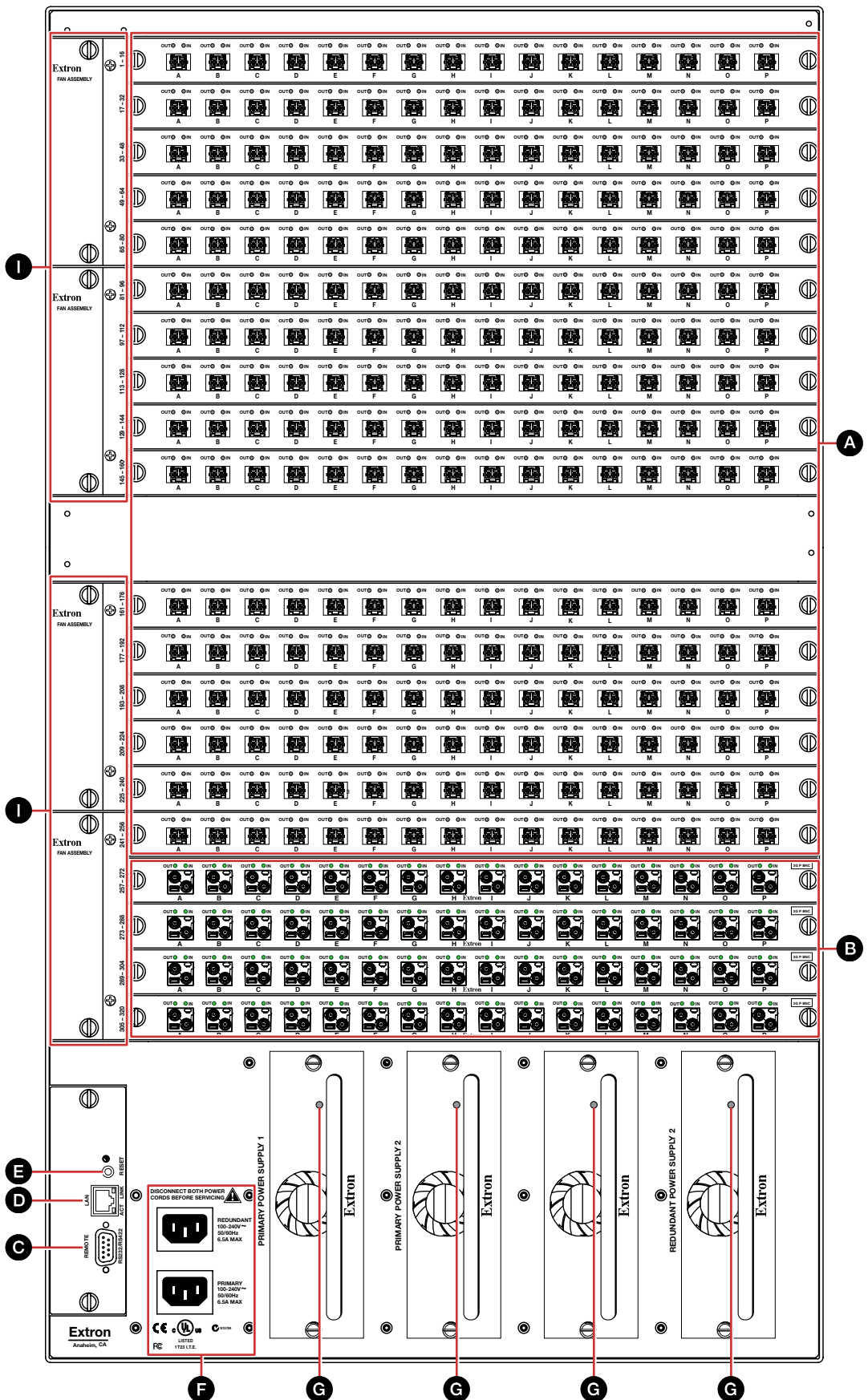

Figure 4. FOX Matrix 320x Switcher Rear Panel

**ATTENTION:**

- Use electrostatic discharge (ESD) precautions (be electrically grounded) when you make connections. ESD is damaging, even if you cannot feel, see, or hear it.
- Prenez des précautions contre les décharges électrostatiques (ESD) (soyez électriquement relié à la terre) lorsque vous effectuez des connexions. Les ESD peuvent endommager l'équipement, même si vous ne pouvez pas le sentir, le voir ou l'entendre.
- Remove system power before making all connections.
- Débranchez l'alimentation du système avant de faire n'importe quelle connexion.

**I/O Boards**

As shown in figure 5, each I/O board is identified by the input and output numbers supported by the board position, which are printed on the side of each fan module (1 - 16, 17 - 32, and so on). The transceiver modules on fiber optic I/O boards and BNC blocks on the 3G/HD/SD-SDI are identified as A through P.

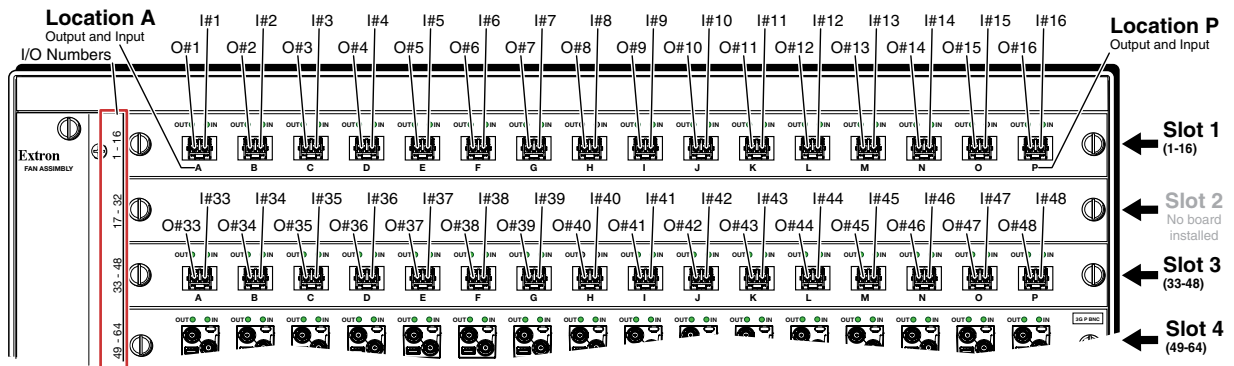

**Figure 5. Arrangement of Inputs and Outputs on the I/O Boards**

Each module, numbered from left to right, includes one of the outputs and one of the inputs supported by the board. For example, the input and output numbers supported by the I/O board in location 33 - 48 (slot 3) are as follows: A = 33, B = 34, C = 35, D = 36, E = 37, F = 38, G = 39, H = 40, I = 41, J = 42, K = 43, L = 44, M = 45, N = 46, O = 47, and P = 48.

**NOTE:** On each transceiver module, the output is to the *left* of the input.

Slot	Inputs and Outputs	Slot	Inputs and Outputs
1	1 through 16	11*	161 through 176
2	17 through 32	12*	177 through 192
3	33 through 48	13*	193 through 208
4	49 through 64	14*	209 through 224
5	65 through 80	15*	225 through 240
6	81 through 96	16*	241 through 256
7	97 through 112	17*	257 through 272
8	113 through 128	18*	273 through 288
9	129 through 144	19*	289 through 304
10*	145 through 160	20*	305 through 320

\* FOX Matrix 320x only

## Fiber optic boards

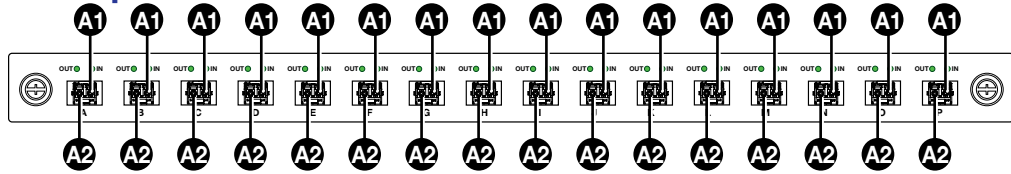

**Figure 6. Fiber Optic Board**

**A** Fiber optic board, connectors (see [figure 3](#) on page 8 and [figure 4](#) on page 9)—

**⚠ WARNING:** The FOX matrix switchers fiber optic I/O boards output continuous invisible light (Class 1 rated), which may be harmful to the eyes; use with caution. Plug the attached dust cap into the optical transceiver when the fiber optic cable is unplugged.

**AVERTISSEMENT :** Le grilles de commutation de la gamme FOX cartes d'entrée/sortie fibre optique émet une lumière invisible en continu (conforme à la classe 1) qui peut être dangereux pour les yeux, à utiliser avec précaution Branchez la protection contre la poussière dans l'ensemble émetteur/récepteur lorsque le câble fibre optique est débranché.

### NOTES:

- Ensure that you use the proper fiber cable for your I/O board. Typically, singlemode fiber has a yellow jacket and multimode cable has an orange or aqua jacket.
- Unlike most Extron transmitters and receivers, which output an optical stream on one connector in a block and receive a return optical stream on the second connector in the same block, the FOX matrix switchers uses one connector on the block as an input and the second connector on the same block as a separate output.
- All transceiver modules on a fiber optic I/O board, as delivered from Extron, are configured the same: either all multimode or all singlemode.
- You can mix multimode and singlemode fiber optic I/O boards in a FOX matrix switcher, but ensure that you connect the proper transmission mode fiber cables to the board.

**A1 Input connector and LED** — For all one-way video, audio, and serial communications output by a transmitter, connect a fiber optic cable to the Input LC connector (see [figure 7](#)).

Connect the far end of this fiber optic cable to the Optical Tx LC connector on a FOXBOX Tx transmitter or to any other compatible Extron fiber optic device.

### NOTES:

- For a FOX 500 transmitter, connect this fiber optic cable to the Optical 1 LC connector.
- **Alternatively**, for the serial return, (receiver-to-transmitter) function, connect the far end of the cable to the Optical 2 connector on a receiver.

**Input LED** — See [Fiber optic I/O board LED indications](#) on the next page.

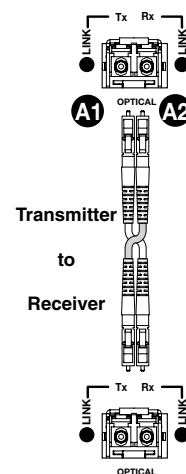

**Figure 7. Optical Connections**

- A2 Output connector** — For all one-way video, audio, and serial communications output to a receiver, connect a fiber optic cable to the Output LC connector (see [figure 7](#), on the previous page).

Connect the far end of this fiber optic cable to the Optical Rx LC connector on a FOXBOX Rx receiver or to any other compatible Extron fiber optic device.

**NOTES:**

- For a FOX 500 receiver, connect this fiber optic cable to the Optical Rx LC connector.
- Alternatively**, for the serial return, (receiver-to-transmitter) function, connect the far end to the Optical 2 connector on a transmitter.

**Output LED** — See “Fiber optic I/O board LED indications,” below.

**Fiber optic I/O board LED indications**

On the fiber optic I/O boards, the input and output LEDs on the transceivers provide useful indications of the status of the lasers and the reclocking function (see the table below).

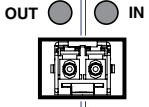
Definition			Definition
	Output LED indication	Input LED indication	
Reclocked at 4.25 Gbps	On	On	Reclocked at 4.25 Gbps
Not reclocked, laser off, or no signal	Off	Off	Not reclocked or no signal
Non-4G signal present or not reclocked	Fast blink	Fast blink	Non-4G signal present or not reclocked

**NOTE:** If the reclocking feature is bypassed (see the [Set output reclocker](#) SIS command on page 26), the output LED is always on.

**3G/HD/SD-SDI boards**

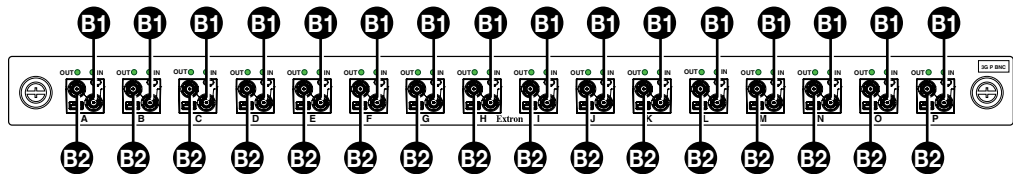
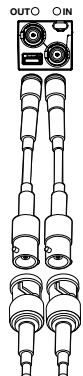

**Figure 8. 3G/HD/SD-SDI Board**

- B BNC connectors** (see [figure 3](#) on page 8 and [figure 4](#) on page 9) — Connect inputs and output using the included DIN-to-female-BNC pigtail connectors, as follows:

**NOTE:** The pigtails are not installed on the board during shipment.

- To install the pigtails**, press them onto the DIN connectors until they snap into place.
- To remove the pigtails**, pull back on the knurled collar and pull the pigtail straight back from the DIN connector.



- B1 Multi-rate SDI Input connectors** — Connect 3G-SDI, HD-SDI, or SDI video inputs to these BNC connectors.
- B2 Multi-rate SDI Output connectors** — Connect digital displays to these BNC connectors.

## Remote Port

- Ⓒ **Remote RS232/RS422 port** (see [figure 3](#) on page 8 and [figure 4](#) on page 9) — Connect a host device, such as a computer or touchpanel control, to the switcher via this 9-pin D connector for serial RS-232 or RS-422 control (see figure 9).

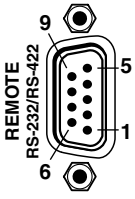

Pin	RS-232 Function	RS-422 Function
1	—	Not used
2	Tx	Transmit data
3	Rx	Receive data
4	—	Not used
5	Gnd	Signal ground
6	—	Not used
7	—	Not used
8	—	Not used
9	—	Not used

**Figure 9. Remote RS232/RS422 Connector**

See [Programming Guide](#), beginning on page 20, for definitions of the SIS commands (serial commands to control the switcher via this connector) and [Matrix Software](#), beginning on page 36, for details on how to install and use the control software.

**NOTE:** The switcher can support either the RS-232 or the RS-422 serial communication protocol, and can operate at 9600, 19200, 38400, or 115200 baud rates.

See the [Command and Response Table for IP- and SNMP-Specific SIS Commands](#) on page 33 to configure this port under SIS control.

If desired, connect any of the following to the Remote RS232/RS422 connector:

- Extron FPC 6000 Front Panel Controller for FOX Matrix 320x and FOX Matrix 14400 (see the *FPC 6000 User Guide* for details).
- MKP 2000 remote control panel (see the *MKP 2000 Remote Control Panel User Guide* for details)
- MKP 3000 remote control panel (see the *MKP 3000 Remote Control Panel User Guide* for details).

## Ethernet Connection

- D LAN port** (see [figure 3](#) on page 8 and [figure 4](#) on page 9) — For IP control of the system, connect the matrix switcher to a PC or to an Ethernet LAN via this RJ-45 connector. You can use a PC to control the networked switcher with SIS commands from anywhere in the world. You can also control the switcher from a PC that is running the Extron Matrix Switchers Control Program or has downloaded HTML pages from the switcher.

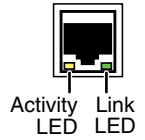

**Link LED indicator** — The green (link) LED indicates that the switcher is properly connected to an Ethernet LAN. This LED should light steadily.

**Act LED indicator** — The amber (activity) LED indicates transmission of data packets on the RJ-45 connector. This LED should flicker as the switcher communicates.

### Cabling

It is vital that your Ethernet cables be the correct cable type and that they be properly terminated with the correct pinout. Ethernet links use Category (CAT) 3, 5e, or CAT 6, unshielded twisted pair (UTP) or shielded twisted pair (STP) cables, terminated with RJ-45 connectors. Ethernet cables are limited to a length of 328 feet (100 meters).

#### NOTES:

- Do not use standard telephone cables. Telephone cables do not support Ethernet or Fast Ethernet.
- Do not stretch or bend cables. Transmission errors can occur.

The cable used depends on your network speed. The switcher supports both 10 Mbps (10Base-T — Ethernet) and 100 Mbps (100Base-T — Fast Ethernet), half-duplex and full-duplex Ethernet connections.

- 10Base-T Ethernet requires CAT 3 UTP or STP cable at minimum.
- 100Base-T Fast Ethernet requires CAT 5e UTP or STP cable at minimum.

### RJ-45 connector wiring

The Ethernet cable can be terminated as a straight-through cable or a crossover cable and must be properly terminated for your application (see [figure 10](#)).

- Crossover cable** — Direct connection between the computer and the FOX matrix switcher
- Patch (straight) cable** — Connection of the FOX matrix switcher to an Ethernet LAN

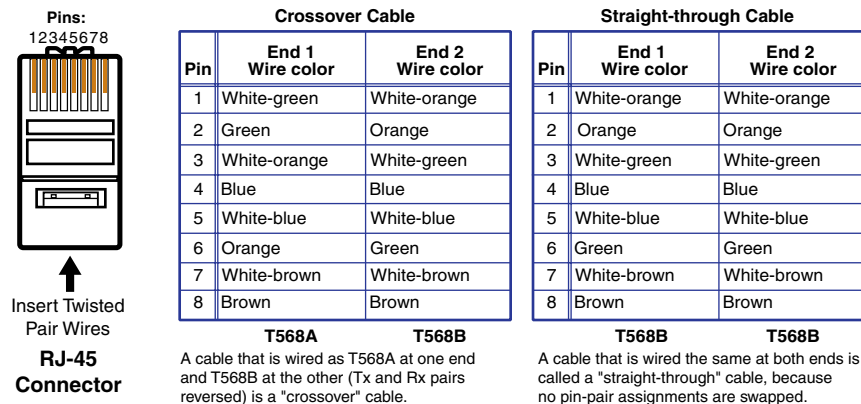

**Figure 10. RJ-45 Connector and Pinout Tables**

## Reset Button and LED

- E Reset button** (see [figure 3](#) on page 8 and [figure 4](#) on page 9) — The recessed **Reset** button initiates four levels of matrix switcher reset. For four different reset levels, press and hold the button while the switcher is running or while you power up the switcher (see [Reset Operations](#) on page 18 for details).



- **Hard reset (mode 1)** — Restore the switcher to the default factory conditions and return the switcher to the default firmware that shipped with the unit.

**NOTE:** Hard reset does not clear the current configuration.

- **Events (mode 3) reset** — Toggle events monitoring on and off.
- **IP settings (mode 4) reset** — Reset the IP functions of the switcher.

**NOTE:** The IP settings reset does not replace any user-installed firmware.

- **Absolute (mode 5) reset** — Restore the switcher to the default factory conditions.

**NOTE:** Factory loaded firmware is active until it is replaced or the power is cycled.

## Power Supply Modules and Indicator LEDs

- F Primary and Redundant AC power connectors** (see [figure 3](#) and [figure 4](#)) — Plug standard IEC power cords into these connectors to connect the switcher to 100 VAC to 240 VAC, 50 or 60 Hz power sources.

**NOTE:** For the most reliable power, connect the a power cord from the Redundant power connector to either an uninterruptible power source or to a power source that is completely independent from the primary power source.

- G Primary and Redundant power supply indicator LEDs** (see [figure 3](#) and [figure 4](#)) —
- Green** — Indicates that the associated power supply is operating within normal tolerances.
- Red** — Indicates that the associated power supply is operating outside the normal tolerances or has failed (see [Removing and Installing a Power Supply Module](#) on page 78 to replace the power supply).

## Cooling Fan Assemblies

- I Primary and Redundant cooling fans** (see [figure 3](#) and [figure 4](#)) — Cool the equipment. If a fan has failed, replace it at your earliest opportunity (see [Removing and Installing a Fan Module](#) on page 80 to replace the fans).

## Front Panel Features

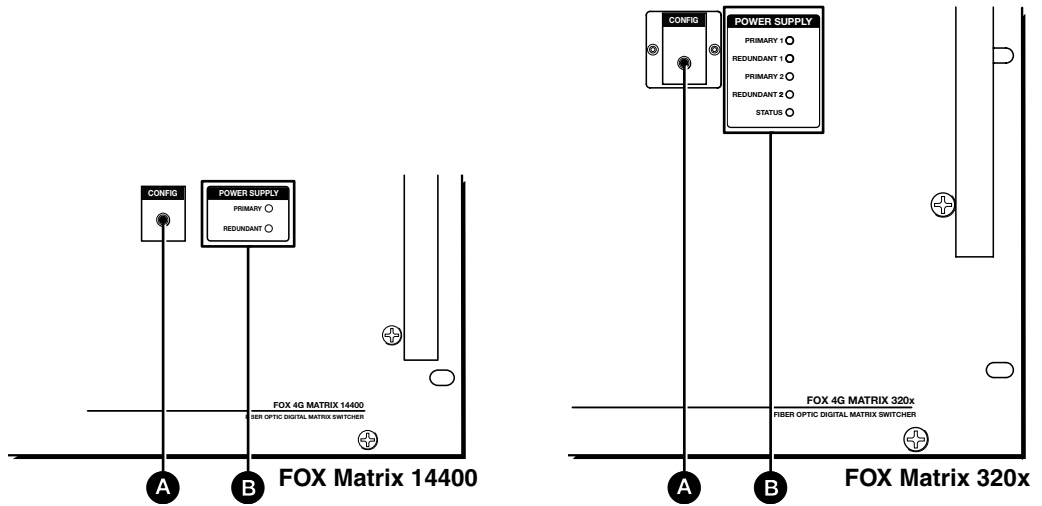

**Figure 11. Front Panel Configuration Port and LED Indicators**

- A Configuration port** — This 2.5 mm mini stereo jack serves the same serial communications function as the rear panel Remote port (although RS-232 only), but it is easier to access than the rear port after the matrix switcher has been installed and cabled. The optional 9-pin D to 2.5 mm mini jack TRS RS-232 cable (see figure 12), can be used for this connection.

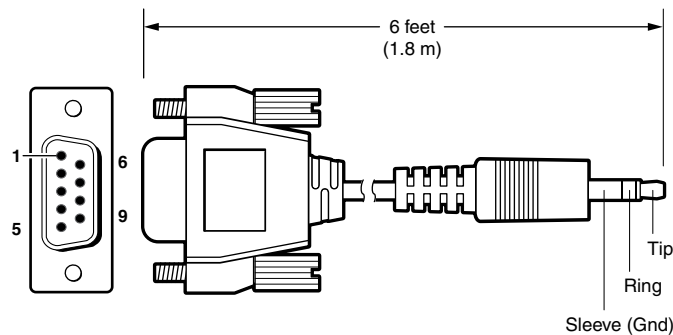

9-pin D	Connection	TRS Plug
Pin 2	Rx line on the computer	Tip
Pin 3	Tx line on the computer	Ring
Pin 5	Signal ground on the computer	Sleeve

**Figure 12. Optional 9-pin TRS RS-232 Cable**

**NOTES:**

- This port is independent of the rear panel Remote port and is not affected by changes to the protocol of the rear panel port. This front panel port protocol can be changed under SIS command control only (see the **Serial Port Parameters** SIS command on page 34 to configure this port under SIS control).
- A front panel Configuration port (RS-232) connection and a rear panel Remote port connection can both be active at the same time.

This port is RS-232 only, with its default protocols as follows:

- 9600 baud
- no parity
- 8 data bits
- 1 stop bit
- no flow control

**NOTE:** The maximum distance from the matrix switcher to the controlling device can be up to 200 feet (61 meters). Factors such as cable gauge, baud rates, environment, and output levels (from the switcher and the controlling device) all affect transmission distance. Distances of about 50 feet (15 meters) or less are typically not a problem. In some cases, the matrix switcher may be capable of serial communications via RS-232 up to 250 feet (76 meters) away.

**B Power Supply and Status LEDs —**

**Primary and Redundant Power Supply LEDs —**

- **Green** — Indicates that the associated power supply is operating within normal tolerances.
- **Amber (FOX Matrix 320x only)** — Indicates that AC power has been disconnected or the power supply has been removed.
- **Red** — Indicates that the associated power supply is operating outside the normal tolerances or has failed (see **Removing and Installing a Power Supply Module** on page 78 to replace the power supply).

**Status LED (FOX Matrix 320x only) —**

- **Green** — Indicates that the controller board is operating normally and that the temperature and backplane voltages are all within normal tolerances.
- **Red** — Indicates that either the controller board has failed or that temperature or backplane voltages are outside of acceptable levels (see the **Request system status** SIS command on page 31 to identify the source of the indication).

## Reset Operations

The rear panel **Reset** button initiates four levels of resets (numbered 1, 3, 4, and 5 for the sake of comparison with an Extron IPL product). The **Reset** button is recessed, so use a pointed stylus, ballpoint pen, or small screwdriver to access it.

See the following table for a summary of the modes.

### ATTENTION:

- Review the reset modes carefully. Using the wrong reset mode may result in unintended loss of flash memory programming, port reassignment, or a controller reboot.
- Étudier de près les différents modes de réinitialisation. Appliquer le mauvais mode de réinitialisation peut causer une perte inattendue de la programmation de la mémoire flash, une reconfiguration des ports ou une réinitialisation du contrôleur.

**NOTE:** The reset modes listed below close all open IP and Telnet connections and close all sockets. Also, the following modes are separate functions, not a continuation from mode 1 to mode 5.

Reset Mode Comparison and Summary			
Mode	Activation	Result	Purpose and Notes
1 Factory Firmware Reset	Hold down the recessed <b>Reset</b> button while applying power to the switcher.  <b>NOTE:</b> After a mode 1 reset is performed, update the switcher firmware to the latest version. Do not operate the switcher firmware version that results from the mode 1 reset. If you want to use the factory default firmware, you must upload that version again (see <b>Updating firmware</b> on page 48 for details on uploading firmware).	<b>The switcher reverts to the factory default firmware.</b> Event scripting does not start if the switcher is powered on in this mode. All user files and settings, such as IP settings, are maintained.  <b>NOTE:</b> If you do not want to update firmware, or you performed a mode 1 reset by mistake, cycle power to the switcher to return to the firmware version that was running before the mode 1 reset. Use the <b>00</b> (Query controller firmware version) SIS command on page 31 to confirm that the factory default firmware is no longer running (look for the asterisk [*] following the version number).	Use mode 1 to return the switcher to the factory default firmware version if incompatibility issues arise with user-loaded firmware.
3 Run/Stop Program Reset	Hold the <b>Reset</b> button for approximately 3 seconds, until the Reset LED blinks once, then momentarily press <b>Reset</b> within 1 second.	<b>Mode 3 turns events on or off.</b> During resetting, the Reset LED blinks two times if events are starting, three times if events are stopping.	Mode 3 is useful for troubleshooting.
4 Reset All IP Settings Reset	Hold the <b>Reset</b> button for approximately 6 seconds, until the Reset LED blinks twice (once at 3 seconds and again at 6 seconds). Then momentarily press <b>Reset</b> within 1 second.	<b>Mode 4:</b> <ul style="list-style-type: none"> <li>• Enables ARP capability.</li> <li>• Sets the IP address to the factory default.</li> <li>• Sets the subnet address to the factory default.</li> <li>• Sets the gateway address to the factory default.</li> <li>• Sets port mapping to the factory default.</li> <li>• Turns DHCP off.</li> <li>• Turns events off.</li> </ul> The Reset LED blinks four times in succession during the reset.	Mode 4 enables you to set IP address information using ARP and the MAC address.

Reset Mode Comparison and Summary (continued)			
Mode	Activation	Result	Purpose and Notes
5 Reset to Factory Default	Hold the <b>Reset</b> button for approximately 9 seconds, until the Reset LED blinks three times (once at 3 seconds, again at 6 seconds, and then again at 9 seconds). Then momentarily press <b>Reset</b> within 1 second. <div style="border: 1px solid black; padding: 5px; margin-top: 10px;"> <p><b>NOTE:</b> The factory configured passwords for all accounts on this device have been set to the device serial number. In the event of a complete system reset, the passwords convert to the default, which is no password.</p> </div>	<p><b>Mode 5 performs a complete reset to factory defaults (with the exception of the firmware):</b></p> <ul style="list-style-type: none"> <li>• Does everything mode 4 does.</li> <li>• Resets most settings, including:               <ul style="list-style-type: none"> <li>• Clears all ties.</li> <li>• Clears all presets.</li> <li>• Clears all output mutes.</li> </ul> </li> <li>• <b>(FOX Matrix 320x)</b> Sets the output lasers to always on.</li> <li>• Resets all IP options.</li> <li>• Removes all user-loaded files and configurations from the switcher.</li> </ul> <p>The reset LED blinks four times in succession during the reset.</p>	Mode 5 is useful if you want to start over with configuration and uploading or to replace events. Same as the <code>EscZQQQ←</code> SIS command on page 29.

## Performing Soft System Resets (Resets 3, 4, and 5)

Perform a soft reset of the switcher as follows (see figure 13):

1. Use a small screwdriver to press and **hold** the rear panel **Reset** button until the rear panel Reset LED blinks once (program reset), twice (IP settings reset), or three times (factory default reset).

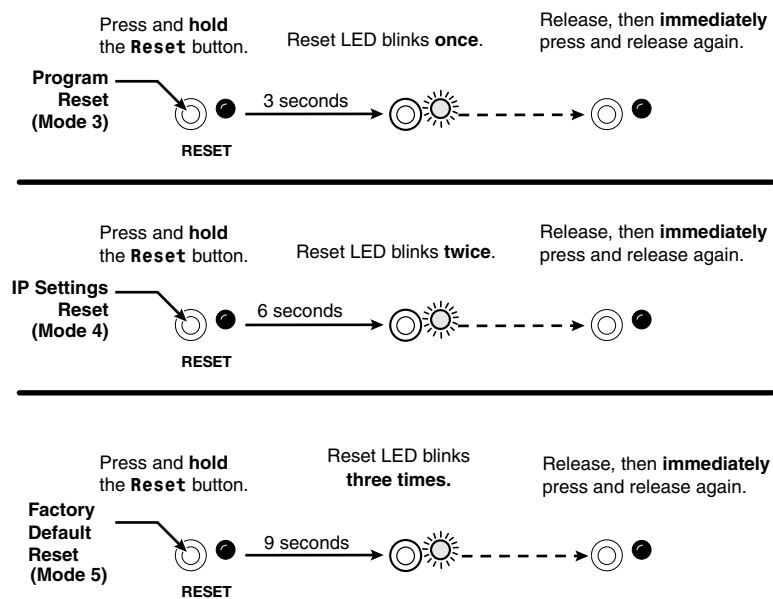

**Figure 13. Resets**

2. Release the **Reset** button and then immediately press and release the **Reset** button again. Nothing happens if the second momentary press does not occur within 1 second.

# Programming Guide

This section describes the operation of the FOX matrix switchers using the Simple Instruction Set, including:

- **Host Control Ports**
- **Host-to-Switcher Instructions**
- **Switcher-Initiated Messages**
- **Switcher Error Responses**
- **Using the Command and Response Tables**
- **Special Characters**

## Host Control Ports

The switcher has two serial ports and an Ethernet LAN port. Any of these ports can be connected to a host device such as a computer running either the Extron DataViewer utility or the HyperTerminal utility or a control system. These ports make control of the switcher possible.

### Serial Ports

The serial ports are:

- **Rear panel Remote port** — A 9-pin D connector for serial RS-232 or RS-422 control (see **Remote Port** on page 13).
- **Front panel Configuration port** — A 2.5 mm mini stereo jack for serial RS-232 control (see **Front Panel Features** on page 16).

The default protocol for both ports is as follows:

- 9600 baud
- no parity
- 8 data bits
- 1 stop bit
- no flow control

The ports can be configured to operate at the 9600, 19200, 38400, or 115200 baud rate.

#### NOTES:

- These two ports are independent of one another. A front panel Configuration port connection and a rear panel Remote port connection can both be active at the same time. Commands are processed in the order received.
- The switcher can operate at 9600, 19200, 38400, or 115200 baud rates, but Extron recommends leaving these ports at 9600 baud only.
- The protocol of these ports can be changed via an SIS command only (see the **Set serial port parameters** SIS command on page 34 to configure these ports using an SIS command).

## Ethernet (LAN) Port

The rear panel Ethernet port on the switcher can be connected to an Ethernet LAN or WAN (see **Ethernet Connection** on page 14). Communications between the switcher and the controlling device is via telnet (a TCP socket using port 23). The TCP port can be changed if necessary. This connection makes SIS control of the switcher possible using a computer connected to the same LAN or WAN. The SIS commands and actions of the switcher are identical to the commands and actions the switcher has when communicating to it via RS-232.

### Establishing a connection

Establish a network connection to a FOX matrix switcher as follows:

1. Open a TCP socket to port 23 using the IP address of the switcher.

**NOTE:** If the local system administrators have not changed the value, the factory-specified default, 192.168.254.254, is the value for this field.

The switcher responds with a copyright message including the copyright year, the name of the product, firmware version, part number, and the current date and time.

#### NOTES:

- The factory configured passwords for all accounts on this device have been set to the device serial number. Passwords are case sensitive
- On password-protected connections, there are two levels of protection: administrator and user.
  - Administrators have full access to all switching capabilities and editing functions.
  - Users can create ties, create and recall presets, set mutes, and view all settings with the exception of passwords.
- If the switcher is not password-protected, the device is ready to accept SIS commands immediately after it sends the copyright message.
- If the switcher is password-protected, a **password** prompt appears below the copyright message.

2. If the switcher is password protected, enter the appropriate administrator or user password.

If the password is accepted, the switcher responds with **Login User** or **Login Administrator**.

If the password is not accepted, the **Password** prompt reappears.

### Connection timeouts

The Ethernet link times out after a designated period of time of no communications. By default, this timeout value is set to five minutes but the value can be changed (see the **Configure port timeout** SIS commands on page 34).

**NOTE:** Extron recommends leaving the default timeout at 5 minutes and periodically issuing the SIS **Q** command (see **Query firmware version** SIS command on page 31) to keep the connection active. If there are long idle periods, Extron recommends disconnecting the socket and reopening the connection when another command must be sent.

## Number of connections

A FOX matrix switcher can have up to 200 simultaneous TCP connections, including all HTTP sockets and Telnet connections. When the connection limit is reached, the switcher accepts no new connections until some have been closed. No error message or indication is given that the connection limit has been reached. To maximize performance of an IP Link device, keep the number of connections low and close unnecessary open sockets.

## Using Verbose Mode

Telnet connections to a FOX matrix switcher can be used to monitor for changes that occur on the switcher, such as front panel operations and SIS commands from other Telnet sockets or a serial port. For a Telnet session to receive change notices from the switcher, the Telnet session must be in verbose mode 1 or 3 (see the **Verbose Mode** SIS command on page 34).

## Host-to-Switcher Instructions

SIS commands consist of one or more characters per field. No special characters are required to begin or end a command character sequence. When a command is valid, the unit executes it and sends a response to the host device. All responses from the unit to the host end with a carriage return and a line feed (CR/LF = ↵), which signals the end of the response character string. A string is one or more characters.

## Switcher-initiated Messages

When a local event, such as an equipment power-up, occurs, the unit responds by sending a message to the host. The unit-initiated messages are listed below:

```
(c) Copyright 20yy, Extron Electronics, FOX Matrix 320x, Vx.xx, 60-nnnn-01↵  
{day,date,time}↵
```

- or -

```
(c) Copyright 20yy, Extron Electronics, FOX Matrix 14400, Vx.xx, 60-nnnn-01↵  
{day,date,time}↵
```

The switcher issues the appropriate copyright message (above) when it first powers on. Vx.xx is the firmware version number; 60-xxxx-xx is the part number of the connected unit.

**NOTE:** {Day, date, time} are reported only if the connection is via the LAN port.

### ↵Password:

The switcher initiates the password message immediately after the copyright message when the controlling system is connected using TCP/IP or Telnet and the switcher is password protected. The switcher requires an administrator or user level password before it will perform the commands entered via this link. The switcher repeats the password message response for every entry other than a valid password until a valid password is entered.

**NOTE:** The factory configured passwords for all accounts on this device have been set to the device serial number. Passwords are case sensitive.

### ↵Login Administrator↵

### ↵Login User↵

The switcher initiates the login message when a correct administrator or user password has been entered. If the user and administrator passwords are the same, the switcher defaults to administrator privileges.

## Switcher Error Responses

When the switcher receives a valid SIS command, it executes the command and sends a response to the host device. If the unit is unable to execute the command because the command is invalid or it contains invalid parameters, the unit returns an error response to the host. The error response codes are:

- E01 — Invalid input channel number (too large)
- E10 — Invalid command
- E11 — Invalid preset number
- E12 — Invalid output number (too large)
- E13 — Invalid value (out of range)
- E14 — Illegal command for this configuration
- E17 — Timeout (caused only by direct write of global presets)
- E21 — Invalid room number
- E24 — Privilege violation (Ethernet only. Personnel logged in as users attempting operations requiring administrator privileges. Users have access to all view and read commands [other than the administrator password], and can create ties and presets, and mute and unmute the output.)

## Using the Command and Response Tables

The **command and response table** begins on **page 25**. Either uppercase or lower case letters are acceptable in the command field. Symbols, defined starting below and used throughout the table, represent variables in the command and response fields. Command and response examples are shown throughout the table. The ASCII to Hex conversion table below is for use with the command and response table.

		ASCII to Hex Conversion Table																Esc	1B	CR	0D	LF	0A
Space	→	20	!	21	"	22	#	23	\$	24	%	25	&	26	'	27							
		(	28	)	29	*	2A	+	2B	,	2C	-	2D	.	2E	/	2F						
		0	30	1	31	2	32	3	33	4	34	5	35	6	36	7	37						
		8	38	9	39	:	3A	;	3B	<	3C	=	3D	>	3E	?	3F						
		@	40	A	41	B	42	C	43	D	44	E	45	F	46	G	47						
		H	48	I	49	J	4A	K	4B	L	4C	M	4D	N	4E	O	4F						
		P	50	Q	51	R	52	S	53	T	54	U	55	V	56	W	57						
		X	58	Y	59	Z	5A	[	5B	\	5C	]	5D	^	5E	_	5F						
		`	60	a	61	b	62	c	63	d	64	e	65	f	66	g	67						
		h	68	i	69	j	6A	k	6B	l	6C	m	6D	n	6E	o	6F						
		p	70	q	71	r	72	s	73	t	74	u	75	v	76	w	77						
		x	78	y	79	z	7A	{	7B		7C	}	7D	~	7E	DEL	7F						



## Command and Response Table for SIS Commands

Command	SIS Command (Host to Unit)	Response (Unit to Host)	Additional description
<b>NOTES:</b>			
<ul style="list-style-type: none"> <li>The matrix switchers support 1-, 2-, and 3-digit numeric entries (1*1, 02*02, or 003*003).</li> <li>Commands can be entered back-to-back in a string, with no spaces. For example: 1*1!02*02&amp;003*003%.</li> </ul>			
<b>Create ties</b>			
<b>NOTES:</b>			
<ul style="list-style-type: none"> <li>The quick multiple tie and tie input to all output commands activate all I/O switches simultaneously.</li> <li>The <b>!</b> tie command, <b>&amp;</b> tie command, and <b>%</b> tie command can be used interchangeably.</li> <li>The <b>!</b> tie all command, <b>&amp;</b> tie all command, and <b>%</b> tie all command can be used interchangeably.</li> <li>When you create a tie where <math>\overline{x1} = 000</math>, you tie no input to the specified output (<math>\overline{x2}</math>) (untie <math>\overline{x2}</math>). When you create a tie where <math>\overline{x2} = 000</math>, you untie all outputs from input <math>\overline{x1}</math>.</li> </ul>			
Tie input $\overline{x1}$ to output $\overline{x2}$ <i>Example:</i>	$\overline{x1}*\overline{x2}!$ 1*3!	Out $\overline{x2}$ •In $\overline{x1}$ •A11← Out003•In001•A11←	Tie input $\overline{x1}$ to output $\overline{x2}$ . Tie input 1 to output 3.
Tie input $\overline{x1}$ to output $\overline{x2}$ <i>Example (see 2nd Note bullet, above):</i>	$\overline{x1}*\overline{x2}\&$ 10*4&	Out $\overline{x2}$ •In $\overline{x1}$ •RGB← Out004•In010•RGB←	Tie input $\overline{x1}$ to output $\overline{x2}$ . Tie input 10 to output 4.
Tie input $\overline{x1}$ to output $\overline{x2}$ <i>Example (see 2nd Note bullet, above):</i>	$\overline{x1}*\overline{x2}\%$ 7*5%	Out $\overline{x2}$ •In $\overline{x1}$ •Vid← Out005•In007•Vid←	Tie input $\overline{x1}$ to output $\overline{x2}$ . Tie input 7 to output 5.
Quick multiple tie <i>Example:</i>	$\overline{Esc}+Q\overline{x1}*\overline{x2}!... \overline{x1}*\overline{x2}! \leftarrow$ $\overline{Esc}+Q3*4!3*5\%3*6!4*7! \leftarrow$	Qik← Qik←	!, &, and % ties are valid. Tie input 3 to output 4, output 5, and output 6. Tie input 4 to output 7.
Tie input to all outputs <i>Example (see last Note bullet, above):</i>	$\overline{x1}*!$ 5*!	In $\overline{x1}$ •A11← In005•A11←	Tie input $\overline{x1}$ to all outputs. Tie input 5 to all outputs.
<b>TIP:</b> 0*! clears all ties.			
Tie input to all outputs <i>Example (see last Note bullet, above):</i>	$\overline{x1}* \&$ 8* &	In $\overline{x1}$ •RGB← In008•RGB←	Tie input $\overline{x1}$ to all outputs. Tie input 8 to all outputs.
Tie input to all outputs <i>Example (see last Note bullet, above):</i>	$\overline{x1}* \%$ 10* %	In $\overline{x1}$ •Vid← In010•Vid←	Tie input $\overline{x1}$ to all outputs. Tie input 10 to all outputs.
<b>Read ties</b>			
<b>NOTES:</b>			
<ul style="list-style-type: none"> <li>The <b>!</b> read tie command, <b>&amp;</b> read tie command, and <b>%</b> read tie command can be used interchangeably.</li> <li>When the switcher is in verbose mode, the response is Out<math>\overline{x2}</math>•In<math>\overline{x1}</math>•(A11)(RGB) or (Vid)←.</li> </ul>			
Read tied input	$\overline{x2}!$	$\overline{x1}$ ←	Input $\overline{x1}$ is tied to output $\overline{x2}$ .
Read tied input, RGB output	$\overline{x2}\&$	$\overline{x1}$ ←	Input $\overline{x1}$ is tied to output $\overline{x2}$ .
Read tied input, Vid output	$\overline{x2}\%$	$\overline{x1}$ ←	Input $\overline{x1}$ is tied to output $\overline{x2}$ .
<b>Channel mutes</b>			
Channel mute	$\overline{x2}*1B$	Vmt $\overline{x2}*1$ ←	Mute output $\overline{x2}$ (no signal is output, but the light output remains active).
Channel unmute	$\overline{x2}*0B$	Vmt $\overline{x2}*0$ ←	Unmute output $\overline{x2}$ (signal is output).
Read channel mute status	$\overline{x2}B$	$\overline{x3}$ ←	0 = mute off, 1 = mute on.
Global channel mute	1*B	Vmt1←	Mute all output channels.
Global channel unmute	0*B	Vmt0←	Unmute all output channels.
<b>KEY:</b>			
$\overline{x1}$ = Input number	000 – (maximum number of inputs for your configuration) (000 = untied)		
$\overline{x2}$ = Output number	001 – (maximum number of outputs for your configuration)		
$\overline{x3}$ = Mute	0 = not muted; 1 = muted		

## Command and Response Table for SIS Commands (continued)

Command	SIS Command (Host to Unit)	Response (Unit to Host)	Additional description
<b>Reclocking</b>			
<b>NOTES:</b>			
<ul style="list-style-type: none"> <li>Laser board reclockers are set on a per SFP basis. If an SFP is reclocked, the corresponding input and output reclockers reclock at the same rate.</li> <li>HD-SDI reclockers are set on a per output basis only.</li> <li>If the connected input or output device is a FOX USB Extender unit, ensure that the re-clockers are set to bypass mode.</li> </ul>			
Set output reclocker	<b>X4</b> * <b>X5</b> =	Rte <b>X4</b> * <b>X5</b> ←	Set the rate for reclocker <b>X4</b> to <b>X5</b> .
<i>Example:</i>	8*00=	Rte08*00←	Set the rate for reclocker 8 to bypass.
Read reclocker status	<b>X4</b> =	<b>X5</b> ←	Show current rate status for reclocker <b>X4</b> .
<b>Laser controls</b>			
Enable individual laser driver	<b>Esc</b> <b>X2</b> *1FIBR←	Fibr <b>X2</b> *1←	Enable the laser for output <b>X2</b> . The laser lights so long as power is applied.
Disable individual laser driver	<b>Esc</b> <b>X2</b> *0FIBR←	Fibr <b>X2</b> *0←	Disable the laser for output <b>X2</b> . The laser is off.
Set individual output laser driver to automatic	<b>Esc</b> <b>X2</b> *2FIBR←	Fibr <b>X2</b> *2←	Set the laser driver for output <b>X2</b> to automatic. The laser lights when a tie is made to output <b>X2</b> , but is off when no tie is made to output <b>X2</b> or the output is muted.
Read status of all laser drivers	<b>Esc</b> FIBR←	<b>X6</b> · <b>X6</b> · <b>X6</b> · <b>X6</b> · ... <b>X6</b> ·←	List the laser driver status of all installed outputs. <i>n</i> is the highest numbered output for your switcher.
Global laser enable	<b>Esc</b> 1*FIBR←	Fibr1←	Enable all output laser drivers.
<b>NOTE:</b> If your switcher has <b>any</b> BNC 3G/HD/SD-SDI boards installed, the global commands are not available. The switcher returns E14.			
Global laser disable	<b>Esc</b> 0*FIBR←	Fibr0←	Disable all output laser drivers.
Global laser automatic	<b>Esc</b> 2*FIBR←	Fibr2←	Set all output laser drivers to automatic.
<b>Save, recall, and directly write presets</b>			
<b>NOTES:</b>			
<ul style="list-style-type: none"> <li>If you try to recall a preset that is not saved, the matrix switcher responds with the error code E11.</li> <li>The following characters are invalid or not recommended in preset names: + , ` @ = [ ] { } ' " ; :   \ and ?.</li> </ul>			
Save current configuration as a global preset	<b>X7</b> ,	Spr <b>X7</b> ←	Command character is a comma.
<i>Example:</i>	9,	Spr9←	Save current ties as preset 9.
Recall a global preset	<b>X7</b> .	Rpr <b>X7</b> ←	Command character is a period.
<i>Example:</i>	5.	Rpr05←	Recall preset 5, to become the current configuration.
<b>Direct write process</b>			
<b>NOTE:</b> The direct write of a global preset should always be preceded by a clear global preset ties command of that same preset number. In a directly-written preset, the tied input of each output position (or no tied input) remains unchanged unless overwritten or cleared.			
If you do not clear the ties in a global preset number before you directly write a global preset to that number, ties that are part of the previous version of the specified preset with the same number can unexpectedly become part of the newly-created preset.			
Clear ties of a global preset	<b>Esc</b> + <b>X7</b> P0*!←	Spr <b>X7</b> ←	Clear all ties in preset <b>X7</b> .
Directly write a global preset	<b>Esc</b> + <b>X7</b> P <b>X1</b> * <b>X2</b> ! <b>X1</b> * <b>X2</b> % <b>X1</b> * <b>X2</b> ! ... <b>X1</b> * <b>X2</b> %←	Spr <b>X7</b> ←	Enter as many ties as are valid for this configuration. The <b>!</b> tie, <b>&amp;</b> tie, and <b>%</b> tie commands are all valid.
<i>Example:</i>	<b>Esc</b> +27P0*!←	Spr27←	Clear all ties in preset 27.
	<b>Esc</b> +27P12*5! <b>10</b> *09%3*2! <b>3</b> *8&←	Spr27←	<u>Brackets are shown to separate ties for clarity only.</u> Create global preset 27, which ties input 12 to output 5, input 10 to output 9, input 3 to output 2, and input 3 to output 8.
<b>KEY:</b>			
<b>X1</b> = Input number	000 – (maximum number of inputs for your configuration) (000 = untied)		
<b>X2</b> = Output number	001 – (maximum number of outputs for your configuration)		
<b>X4</b> = SFP or reclockable output	000 – 144 or 320 (FOX Matrix 320x) (000 = global [SFP only])		
<b>X5</b> = Output reclocking rate	00 = Bypass mode		
	01 = Automatic mode (HDSDI [default] only) or N/A (laser)		03 = 2.125 Gbps (laser only)
	02 = 1.250 Gbps (laser boards only)		04 = 4.250 Gbps (laser only [default])
<b>X6</b> = Laser control	0 = disable	1 = enable (default)	2 = automatic
<b>X7</b> = Global preset number	00 – 64		

## Command and Response Table for SIS Commands (continued)

Command	SIS Command (Host to Unit)	Response (Unit to Host)	Additional description
<b>Save, recall, and directly write presets (continued)</b>			
<b>NOTES:</b>			
<ul style="list-style-type: none"> <li>A room can contain a maximum of 16 outputs (<math>\overline{x2}</math>s).</li> <li>If a room is not defined (does not exist in the switcher), the matrix switcher responds with the error code E11.</li> <li>An output can belong to only one room.</li> <li>The maximum number of rooms (<math>\overline{x8}</math>) is 10.</li> </ul>			
Write room outputs <i>Example:</i>	$\overline{\text{Esc}}\overline{x8}, \overline{x2}^1, \overline{x2}^2, \dots \overline{x2}^n \text{MR} \leftarrow$ $\overline{\text{Esc}}8, 3, 04, 5, 6 \text{MR} \leftarrow$	$\text{Mpr}\overline{x8}, \overline{x2}^1, \overline{x2}^2, \dots \overline{x2}^n \leftarrow$ $\text{Mpr}8, 03, 04, 05, 06 \leftarrow$	See the notes below. Outputs 3, 4, 5, and 6 are assigned to room 8.
Read room outputs	$\overline{\text{Esc}}\overline{x8} \text{MR} \leftarrow$	$\overline{x9}, \overline{x2}^1, \overline{x2}^2, \dots \overline{x2}^n \leftarrow$	
<b>NOTES:</b>			
<ul style="list-style-type: none"> <li>If no outputs have been assigned to the room, the switcher returns [unassigned] <math>\leftarrow</math>.</li> <li>The default name (<math>\overline{x9}</math>) is the room number with four trailing spaces: "Room•#<math>\overline{x8}</math>••••".</li> </ul>			
<i>Example:</i>	$\overline{\text{Esc}}3 \text{MR} \leftarrow$	$\text{Room}\bullet\#03\bullet\bullet\bullet\bullet, 01, 02, 08, 09 \leftarrow$	Outputs 1, 2, 8, and 9 are assigned to room 3.
Save ties as a room preset	$\overline{x8} * \overline{x10},$	$\text{Rmm}\overline{x8} \bullet \text{Spr}\overline{x10} \leftarrow$	Command character is a comma.
<b>NOTE:</b> You must have assigned outputs to a room ( $\overline{\text{Esc}}\overline{x8}, \text{MR} \leftarrow$ ) before you can save a room preset.			
<i>Example:</i>	$3 * 9,$	$\text{Rmm}03 \bullet \text{Spr}09 \leftarrow$	Save current ties as preset 9 for room 3.
Recall room preset	$\overline{x8} * \overline{x10} .$	$\text{Rmm}\overline{x8} \bullet \text{Rpr}\overline{x10} \leftarrow$	Command character is a period.
Clear room preset ties	$\overline{\text{Esc}} + \overline{x8} * \overline{x10} \text{P}0 * ! \leftarrow$	$\text{Rmm}\overline{x8} \bullet \text{Spr}\overline{x10} \leftarrow$	Clear all ties in room $\overline{x8}$ preset $\overline{x10}$ .
Directly write a room preset	$\overline{\text{Esc}} + \overline{x8} * \overline{x10} \text{P}\overline{x1} * \overline{x2}^1 \overline{x1} * \overline{x2}^2 \overline{x1} * \overline{x2}^3 \overline{x1} * \overline{x2}^4 \dots \overline{x1} * \overline{x2}^n ! \leftarrow$	$\text{Rmm}\overline{x8} \bullet \text{Spr}\overline{x10} \leftarrow$	Enter as many ties as are valid for this configuration. The ! <b>tie</b> command, & <b>tie</b> , and % <b>tie</b> commands are all valid and equivalent. <u>Brackets are shown to separate ties for clarity only.</u> Create preset 3 for room 7, which ties input 12 to output 7, input 11 to output 5, input 4 to output 5, and input 6 to output 6.
<i>Example:</i>	$\overline{\text{Esc}} + 7 * 3 \text{P}12 * 7 \& 11 * 5 \& 4 * 5 \% 6 * 6 ! \leftarrow$	$\text{Rmm}07 \bullet \text{Spr}03 \leftarrow$	
<b>View ties, mutes, and presets</b>			
<b>NOTE:</b> The ! <b>read tie</b> command, & <b>read tie</b> command, and % <b>read tie</b> command can be used interchangeably.			
View tied input	$\overline{x2} !$	$\overline{x1} \leftarrow$	Input $\overline{x1}$ is tied to output $\overline{x2}$ .
View output tie <i>Example:</i>	$\overline{x2} \&$ $15 \&$	$\overline{x1} \leftarrow$ $027 \leftarrow$	Input 27 is tied to output 15.
View output tie <i>Example:</i>	$\overline{x2} \%$ $7 \%$	$\overline{x1} \leftarrow$ $002 \leftarrow$	Input 2 is tied to output 7.
View output mutes	$\overline{\text{Esc}} \text{VM} \leftarrow$	$\overline{x3}^1 \overline{x3}^2 \dots \overline{x3}^n \leftarrow$	Each $\overline{x3}$ response is the mute status of an output, starting from output 1. $n$ is the highest-numbered installed output.
<b>NOTE:</b> The switcher reports the mute status for all outputs, up to the highest numbered output on the highest numbered slot with an I/O board installed. The switcher does not recognize gaps in the board installation. For example, if boards are installed in only slots 1 and 3, leaving slot 2 empty, the switcher returns mute status for 48 sequential outputs. The mute status for the outputs in slot 2, inputs 17 through 32, can be ones or zeroes (the switcher allows you to mute an output that is not installed, so long as it is numbered lower than the highest numbered output installed).			
<b>KEY:</b>			
$\overline{x1}$ = Input number		000 – (maximum number of inputs for your configuration) (000 = untied)	
$\overline{x2}$ = Output number		001 – (maximum number of outputs for your configuration)	
$\overline{x3}$ = Mute		0 = not muted; 1 = muted	
$\overline{x8}$ = Room # (for room presets)		01 – 10 (each can have up to 10 presets ( $\overline{x10}$ s) assigned)	
$\overline{x10}$ = Room preset #		01 – 10	

## Command and Response Table for SIS Commands (continued)

Command	SIS Command (Host to Unit)	Response (Unit to Host)	Additional description
<b>View ties, mutes, and presets (continued)</b>			
View global preset configuration	$\text{Esc}[X7]*[X2]*1\text{VC}\leftarrow$	$[X1]^n\bullet[X1]^{n+1}\bullet\dots\bullet[X1]^{n+15}\bullet\text{Vid}\leftarrow$	Show the configuration of preset $[X7]$ . Show the input tied to 16 sequential outputs, starting from output $[X2]$ . $n$ is the starting output number.
<i>Command description:</i>	preset number $([X7])$ *starting output number $([X2])$ *1VC		
<i>Response description:</i>	input number $([X1])$ tied to $[X2]$ * $[X1]$ tied to $[X2]^{n+1}$ * $[X1]$ tied to $[X2]^{n+2}$ * $[X1]$ tied to $[X2]^{n+15}$ * $[X1]$		
<i>Example (32 x 32 matrix):</i>	$\text{Esc}23*25*1\text{VC}\leftarrow$	<p>input 2 tied to output 27      input 8 tied to output 28      no tied input      outputs do not exist</p> <p>Response = tied input: 008•008•002•008•008•001•000•000•...•Vid</p> <p>Output: 25 26 27 28 29 30 31 32 33 34 35 36 37 38 39 40</p> <p>Each position shown in the response is an output: left = output 25 (the starting output number), right = output 32. (Outputs 33 through 40 are not present on this matrix size.) The number in each position is the input tied to that output.</p> <p>In this example, video input 8 is tied to outputs 25, 26, 28, and 29; input 2 is tied to output 27; and input 1 is tied to output 30. No inputs are tied to outputs 31 and 32.</p>	
<b>NOTE:</b> $\text{Esc}[X7]*[X2]*1\text{VC}\leftarrow$ where $[X7] = 0$ returns 16 ties in the current video configuration of the switcher, starting from output $[X2]$ .			
View room preset configuration	$\text{Esc}[X8]*[X10]*[X2]*1\text{VC}\leftarrow$	$[X1]^n\bullet[X1]^{n+1}\bullet\dots\bullet[X1]^{n+15}\bullet\text{Vid}\leftarrow$	Show the configuration of room $[X8]$ , preset $[X10]$ . Show the input tied to up to 16 outputs assigned to room $[X8]$ . $n$ is the starting output number.
<i>Command description:</i>	room number $([X8])$ *room preset number $([X10])$ *starting output number $([X2])$ *1VC		
<i>Response description:</i>	input number $([X1])$ tied to $[X2]$ * $[X1]$ tied to $[X2]^{n+1}$ * $[X1]$ tied to $[X2]^{n+2}$ * $[X1]$ tied to $[X2]^{n+15}$ * $[X1]$		
<b>List input link detection</b>			
<b>NOTE:</b> The switcher reports the link status for only as many inputs as are supported by the highest numbered slot with an I/O board installed. The switcher does not recognize gaps in the board installation. For example, if only two boards are installed, in slots 1 and 3, leaving slot 2 empty, the switcher returns link status for 48 sequential inputs. The input link response for the inputs supported by the board in slot 2, inputs 17 through 32, are all zeroes.			
View all input connections	$\emptyset\text{LS}$	$[X11]^1[X11]^2[X11]^3\dots[X11]^n\leftarrow$	Each $[X11]$ response is the connection status of all inputs, starting from input 1. $n$ is the highest-numbered installed input.
<i>Example:</i>	$\emptyset\text{LS}$	<p>no input detected      input detected</p> <p>Response Status: 0 0 0 1 1 1 0 . . . 0</p> <p>Input: 1 2 3 4 5 6 7      n</p>	
<b>KEY:</b>			
$[X1]$ = Input number (for tie)	$[X2]$ = Output number	$[X11]$ = Connection status	$[X7]$ = Global preset number
$[X8]$ = Room number (for room presets)	$[X10]$ = Room preset number	$\emptyset\emptyset$ – (maximum number of inputs for your configuration) ( $\emptyset\emptyset$ = untied)	$\emptyset 1$ – (maximum number of outputs for your configuration)
		$\emptyset$ = no input connected    1 = input connected	$\emptyset\emptyset - 64$ ( $\emptyset\emptyset$ = current configuration for views only)
		$\emptyset 1 - 1\emptyset$ (each can have up to 10 presets $([X10]$ s) assigned)	$\emptyset 1 - 1\emptyset$ maximum

## Command and Response Table for SIS Commands (continued)

Command	SIS Command (Host to Unit)	Response (Unit to Host)	Additional description
<b>Names</b>			
<b>NOTES:</b>			
<ul style="list-style-type: none"> <li>The HTML language reserves certain characters for specific functions (see <a href="#">Special Characters</a> on page 35).</li> <li>Do not use leading spaces in preset names.</li> <li>If a preset is unassigned, the <b>X10</b> displays [unassigned].</li> <li>If a global preset is saved, but not yet named, the default name is <b>Preset•X7</b>.</li> <li>If a room preset is saved, but not yet named, the default name is <b>RmX8•PrstX9</b>.</li> </ul>			
Write global preset name	<b>EscX7, X9NG</b> ←	NmgX7, X9←	
<i>Example:</i>	<b>Esc1, Security 1NG</b> ←	Nmg001, Security 1←	Name global preset 1 “Security 1”.
Read global preset name	<b>EscX7NG</b> ←	X9←	
<i>Example:</i>	<b>Esc2NG</b> ←	Security 2←	Global preset 2 is named “Security 2”.
Write room preset name	<b>EscX8* X10, X9NP</b> ←	NmpX8* X10, X9←	
<i>Example:</i>	<b>Esc1*3, Podium_DVDNP</b> ←	Nmp01*3, Podium_DVD←	Name room1, preset 3 “Podium_DVD”.
Read room preset name	<b>EscX8* X10NP</b> ←	X9←	
Write input name	<b>EscX12, X9NI</b> ←	NmiX12, X9←	
<i>Example:</i>	<b>Esc1, Podium camNI</b> ←	Nmi001, Podium cam←	Name input 1 “Podium cam”.
Read input name	<b>EscX12NI</b> ←	X9←	
Write output name	<b>EscX2, X9NO</b> ←	NmoX2, X9←	
<i>Example:</i>	<b>Esc1, Main PJ1NO</b> ←	Nmo001, Main PJ1←	Name output 1 “Main PJ1”.
Read output name	<b>EscX2NO</b> ←	X9←	
<b>Resets</b>			
Reset global presets and names	<b>EscZG</b> ←	Zpg←	Clear all global presets and their names.
Reset <b>one</b> global preset	<b>EscX7ZG</b> ←	ZpgX7←	Clear global preset <b>X7</b> .
Reset all mutes	<b>EscZZ</b> ←	Zpz←	Unmute all outputs.
Reset room map	<b>EscZR</b> ←	Zpr←	Clear all room definitions.
Reset individual room	<b>EscX8ZR</b> ←	ZprX8←	Delete room <b>X8</b> .
Reset all room presets	<b>EscZP</b> ←	Zpp←	Clear all room presets and names.
Reset individual room preset	<b>EscX8* X10ZP</b> ←	ZppX8* X10←	Clear an individual room preset and name.
Reset whole switcher	<b>EscZXXX</b> ←	Zpx←	Clear all ties and presets.
Absolute reset	<b>EscZQQQ</b> ←	Zpq←	Similar to <b>Reset whole switcher</b> , plus clear the IP address to 192.168.254.254 and subnet mask to 255.255.000.000.
<b>NOTE:</b> The factory configured passwords for all accounts on this device have been set to the device serial number. In the event of a complete system reset, the passwords convert to the default, which is no password.			
Reset all device settings	<b>EscZY</b> ←	Zpy←	Similar to absolute reset, <b>above</b> , but excludes the following IP settings: IP address, subnet mask, gateway address, unit name, DHCP setting, and port mapping (Telnet, web, and direct address).
<b>KEY:</b>			
<b>X2</b> = Output number		01 – (maximum number of outputs for your configuration)	
<b>X7</b> = Global preset number		001 – 064	
<b>X8</b> = Room number (for room presets)		01 – 10 (each can have up to 10 presets ( <b>X10</b> s) assigned)	
<b>X9</b> = Name		11 characters maximum for room names	
		12 characters maximum for all other names	
<b>X10</b> = Room preset number		00 – 10 (0 = current configuration for room)	
<b>X12</b> = Input number (for other than tie)		01 – (maximum number of inputs for your configuration)	

## Command and Response Table for SIS Commands (continued)

Command	SIS Command (Host to Unit)	Response (Unit to Host)	Additional description
<b>File management</b>			
<b>NOTE:</b> The response to the View File Directory command differs, depending on whether the command is sent via an RS-232/RS-422 or Telnet connection or sent via a web browser connection.			
View file directory RS-232/RS-422 port and Telnet	<b>Esc</b> DF←	<i>filename1, date and time, length</i> ↵ <i>filename2, date and time, length</i> ↵ •      •↵ •      •↵ <i>filenamen, date and time, length</i> ↵ <i># of Bytes•Left</i> ↵↵	List user-supplied files.
View file directory web browser	<b>Esc</b> DF←	Var file = new array (); File [1] = 'filename1,date1, filesize1'; File [2] = 'filename2,date2, filesize2'; •      • •      •  File [n] = 'filenamen, daten, filesizen'; File [n+1] = # of Bytes•Left	List user-supplied files.
Erase user-supplied web pages or files	<b>Esc</b> <filename>EF←	Del<filename>↵	
<b>Information requests</b>			
Information request	I	V[X13]X[X14]•A[X13]X[X14]•S[X15] <sup>1</sup> [X15] <sup>2</sup> ...[X15] <sup>n</sup> ↵	V[X13]X[X14] shows the number of available inputs and outputs for this configuration. A[X13]X[X14] has no meaning for this product. S[X15] <sup>1</sup> [X15] <sup>2</sup> ...[X15] <sup>n</sup> shows the board type installed in each slot. <i>n</i> is either 9 or 20, depending on the model.
Slot, plane, and LC information	0*[X16]I	[X17] <sup>a</sup> [X17] <sup>b</sup> [X17] <sup>c</sup> ... [X17] <sup>n</sup> ↵	
Request part number	N	60 - nnnn - nn↵	See <a href="http://www.extron.com">www.extron.com</a> , for part numbers.
Request part number and board configuration	*N	60 - nnnn - nn . [X15] <sup>1</sup> [X15] <sup>2</sup> [X15] <sup>3</sup> ... [X15] <sup>n</sup> ↵	Part number plus I/O boards installed. <i>n</i> is either 9 or 20, depending on the model.
Read reclocker status	[X4]=	[X5]↵	Show current reclocker status for output [X4].
<b>NOTE:</b> The switcher automatically detects and reclocks the signal if the rate is 4.25 Gbps <b>only</b> . Other rates are ignored.			
View SFP module status	40*[X18]S	[X20]•[X21]•[X22]•[X23]↵	
<b>KEY:</b>	[X4] = SFP or reclockable output number [X5] = Output reclocking rate  [X13] = Number (quantity) of inputs [X14] = Number (quantity) of outputs [X15] = Board installed  [X16] = I/O board slot number [X17] = Transceiver module installed  [X18] = Transceiver module number [X19] = Reclocking status [X20] = Vendor or manufacturer name [X21] = Transmit output power in milliwatts [X22] = Receive optical power in milliwatts [X23] = SFP temperature	000 – 320 or 144 (FOX Matrix 14400) 00 = Bypass mode 01 = Automatic mode (HDSDI boards only)    03 = 2.125 Gbps (laser boards only) 02 = 1.250 Gbps (laser boards only)        04 = 4.250 Gbps (laser boards only) In sets of 16 (016, 032, 048, 064, and so on) In sets of 16 (016, 032, 048, 064, and so on) 0 = No board installed                        4 = Non-pathological multimode board 1 = Non-reclocking multimode board        5 = Non-pathological singlemode board 2 = Non-reclocking singlemode board       6 = Pathological singlemode board 3 = 3G, SDI, HD-SDI board                 X = Unknown board or mix of transceivers 01 – 20 (FOX Matrix 320x) or 01 – 09 (FOX Matrix 14400) 0 = No module installed 1 = Non-pathological multimode module     3 = 3G-SDI, HD-SDI, SD-SDI module 2 = Non-pathological singlemode module    4 = Pathological singlemode module 001 – 320 (or maximum number of transceiver modules for your configuration) 0 = signal reclocked                         1 = signal not reclocked	Degrees Celsius

## Command and Response Table for SIS Commands (continued)

Command	SIS Command (Host to Unit)	Response (Unit to Host)	Additional description
<b>Information requests (continued)</b>			
<p><b>NOTE:</b> There are up to three separate sets of Extron firmware on which the switcher can report: the controller firmware, which is the overall control firmware; the Ethernet protocol firmware, which handles the Ethernet interface; and the latest optional Extron firmware update, which is available at <a href="http://www.extron.com">www.extron.com</a>.</p>			
Query firmware version <i>Example:</i>	Q Q	<u>X24</u> ← 1.23 ←	The factory-installed controller firmware version is 1.23 (sample value only).
Query controller firmware version (verbose)  <i>Response description:</i>  <i>Example:</i>	ØQ Øq	<u>X24</u> - <u>X25</u> - <u>X25</u> ←  <i>Ethernet protocol firmware version-controller firmware version-updated firmware version</i> ←	Provide a detailed status of the Ethernet protocol firmware, the controller firmware, and any firmware upgrade. An asterisk (*) marks the firmware that is running. A caret (^) marks that the firmware has a bad checksum or an invalid load. ??? marks that firmware is not loaded.
			<p>Description * indicates the version running Upload date and time</p> <p>1.23-1.00(1.68-FOMX Series -Wed, 20 Feb 2008 00:00:00 GMT)-1.00*(1.06-FOMX Series -Mon, 17 Mar 2007 16:39:21 GMT) ←</p> <p>Ethernet protocol firmware FOX Matrix firmware version Updated firmware version</p>
Request system status FOX Matrix 320x FOX Matrix 14400 <i>Response description (FOX Matrix 320x):</i> +3.3V•+5V•+2.5V•+1.8V•+12V (backplane) •+12V (primary PS1)•+12V (redundant PS1)•+12V (Primary PS2)•+12V (redundant PS2)•Temp•Fan1 RPM•Fan2•Fan3•Fan4•Fan5•Fan6•Fan7•Fan8•Pri1 PS status•Red1 PS status•Pri2 PS status•Red2 PS status ← <i>Response description (FOX Matrix 14400):</i> +3.3V•+5V•+1.3V•+1.2V•+12V (backplane)•+12V (redundant PS)•+12V (primary PS)•Temp•Fan1 RPM•Fan2•Fan3•Fan4 ← <i>Example</i> <b>(FOX Matrix 14400):</b>	S S	<u>X26</u> • <u>X26</u> • <u>X26</u> • <u>X26</u> • <u>X26</u> • <u>X26</u> • <u>X26</u> • <u>X26</u> • <u>X26</u> • <u>X26</u> • <u>X26</u> • <u>X27</u> • <u>X28</u> • <u>X28</u> • <u>X28</u> • <u>X28</u> • <u>X28</u> • <u>X28</u> • <u>X28</u> • <u>X28</u> • <u>X29</u> • <u>X29</u> • <u>X29</u> • <u>X29</u> ← <u>X26</u> • <u>X26</u> • <u>X26</u> • <u>X26</u> • <u>X26</u> • <u>X26</u> • <u>X26</u> • <u>X27</u> • <u>X28</u> • <u>X28</u> • <u>X28</u> • <u>X28</u> ←  3.27•4.95•1.31•1.22•12.00•12.06•12.12•+078.80•02909•02909•02909•02860 ← 3.3 V power system at 3.27 V Fan 1 rotating at 2,909 RPM	<p>Backplane receiving 12.00 V Internal temperature 78.8° F</p>
<p><b>KEY:</b> <u>X24</u> = Firmware version number to second decimal place (x.xx)  <u>X25</u> = Verbose firmware version-description-upload date and time. See above  <u>X26</u> = Voltage Positive or negative voltage and magnitude  <u>X27</u> = Switcher temperature Degrees Fahrenheit  <u>X28</u> = Fan speed (in RPM)  <u>X29</u> = Power supply status 1 = Ok Ø = Out of tolerance or failed</p>			

# Command and Response Table for IP- and SNMP-Specific SIS Commands

## Symbol definitions

**X40** = Matrix name (Up to 24 alphanumeric characters)

**NOTE:** The HTML language reserves certain characters for specific functions (see [Special Characters](#) on page 35).

<p><b>X41</b> = Default name</p> <p><b>X42</b> = Time and date (for set)</p> <p><b>X43</b> = Time and date (for read)</p> <p><b>X44</b> = GMT offset</p> <p><b>X45</b> = Daylight Saving Time</p> <p><b>X46</b> = IP address</p> <p><b>X47</b> = Hardware (MAC) address</p> <p><b>X48</b> = Number of open connections</p> <p><b>X49</b> = Password</p>	<p><b>FOX-Matrix</b> - + last 3 pairs of MAC address</p> <p>In the format: MM/DD/YY•HH:MM:SS <i>where:</i>          MM = month: 01 (Jan) through 12 (Dec)          DD = day: 01 through 31          YY = year: 00 through 99          HH = hour: 00 through 23          MM = minutes: 00 through 59          SS = seconds: 00 through 59</p> <p>In the format: Day•DD•Mmm•YYYY•HH:MM:SS <i>where:</i>          Day = weekday: Mon through Sun          DD = date: 01 through 31          Mmm = month: Jan through Dec          YYYY = year: 2000 through 2099          HH = hour: 00 through 24          MM = minutes: 00 through 59          SS = seconds: 00 through 59</p> <p>–12.0 through +14.0. Hours and minutes removed from GMT</p> <p>0 = Daylight Saving Time off or ignore      2 = Daylight Saving Time on (Europe)          1 = Daylight Saving Time on (North America)      3 = Daylight Saving Time on (Brazil)</p> <p>nnn.nnn.nnn.nnn          nn-nn-nn-nn-nn-nn</p> <p>0 – 255</p> <p>12 alphanumeric characters</p>
--	--

**NOTE:** The HTML language reserves certain characters for specific functions (see [Special Characters](#) on page 35).

**X50** = Domain name      Standard domain name rules apply (for example: xxx.com)

**NOTE:** The HTML language reserves certain characters for specific functions (see [Special Characters](#) on page 35). The @ character is acceptable only as the lead-in to the domain name (such as @extron.com).

<p><b>X51</b> = E-mail account 1 through 5</p> <p><b>X52</b> = E-mail address</p> <p><b>X53</b> = Notification selections, part 1</p> <p><b>X54</b> = Notification selections, part 2</p> <p><b>X55</b> = Notify when?</p> <p><b>X56</b> = DHCP and SNMP</p> <p><b>X57</b> = Port number</p> <p><b>X58</b> = Baud rate</p> <p><b>X59</b> = Parity</p> <p><b>X60</b> = Data bits</p> <p><b>X61</b> = Stop bits</p> <p><b>X62</b> = Port type</p> <p><b>X63</b> = Verbose mode</p>	<p>65 – 69. 65 = e-mail recipient 1, 66 = 2, 67 = 3, ... 69 = recipient 5</p> <p>Typical e-mail address format (for example: nnnn@xxx.com)</p> <p>I = inputs      F = fans      P = power supply</p> <p>If <b>X53</b> = I, then      <b>X54</b> = 000 (all inputs), or inputs 001 through 144 (320)          If <b>X53</b> = F, then      <b>X54</b> = 00 (all fans)          If <b>X53</b> = P, then      <b>X54</b> = 00 (all power supplies)</p> <p>0 = no response          1 = fail or missing      3 = both 1 &amp; 2          2 = fixed or restored      4 = suspend</p> <p>0 = off or disable      1 = on or enable</p> <p>00 (all ports), 01 (rear panel), 02 (front panel)</p> <p>9600, 19200, 38400, 115200</p> <p>odd, even, none, mark, space (only the first letter required)</p> <p>7, 8 (default)</p> <p>1 (default), 2</p> <p>0 = RS-232, 1 = RS-422</p> <p>0 = clear or none (default for Telnet connection)          1 = verbose mode (default for RS-232 or RS-422 connection)          2 = tagged responses for queries, verbose mode not enabled          3 = verbose mode and tagged for queries</p>
--	---

**NOTE:** If tagged responses are enabled, all read commands return the constant string and the value as the set command does (for example, the read matrix name command `EscCN←` returns `Ipn•X40←`).

**X64** = Port timeout (10-second increments)

**X65** = SNMP port number

**X66** = SNMP contact name and location

**X67** = SNMP community name

**X68** = Trap target

**X69** = SNMP trap version

**X70** = SNMP target 1 through 3

1 (= 10 seconds) – 65000 (default is 30 = 300 seconds = 5 minutes)

00000 (= disable) – nnnnn. Default = 00161. Leading zeroes are not necessary for entry.

Up to 64 alphanumeric characters. Default = Not Specified.

Up to 64 alphanumeric characters.

Default = public (for read community) or private (for read-write community).

1 – 3

2 or 3, or 0 = empty (default) if no target set

70 – 72. 70 = SNMP target 1, ... 72 = target 3

## Command and Response Table for IP- and SNMP-Specific SIS Commands

Command	ASCII Command (host to unit)	Response (unit to host)	Additional description
<b>IP setup commands</b>			
Set matrix name	<b>Esc</b> X40CN ←	Ip n•X40 ←	
Read matrix name	<b>Esc</b> CN ←	X40 ←	
Reset matrix name to factory default	<b>Esc</b> •CN ←	Ip n•X41 ←	“FOX-Matrix- <i>nnnn</i> ” plus the last 3 pairs of the MAC address. <i>nnnn</i> = 320x or 14400.
Set time and date	<b>Esc</b> X42CT ←	Ipt X42 ←	
Read time and date	<b>Esc</b> CT ←	X43 ←	
Set GMT offset	<b>Esc</b> X44CZ ←	Ipz X44 ←	In the command, the divider between hours and minutes can be either a colon (:) or a period. In the response, the divider is a colon.
<i>Example:</i>	<b>Esc</b> B.0CZ ←	Ipz+08:00 ←	
Set Daylight Saving Time	<b>Esc</b> X45CX ←	Ip xX45 ←	
Read Daylight Saving Time	<b>Esc</b> CX ←	X45 ←	
Set IP address	<b>Esc</b> X46CI ←	Ip i X46 ←	
Read IP address	<b>Esc</b> CI ←	X46 ←	
Read hardware address	<b>Esc</b> CH ←	X47 ←	
Read # of open connections	<b>Esc</b> CC ←	X48 ←	
Set subnet mask	<b>Esc</b> X46CS ←	Ip s X46 ←	
Read subnet mask	<b>Esc</b> CS ←	X46 ←	
Set gateway IP address	<b>Esc</b> X46CG ←	Ip g X46 ←	
Read gateway IP address	<b>Esc</b> CG ←	X46 ←	
Set administrator password	<b>Esc</b> X49CA ←	Ip a•X49 ←	
<b>NOTES:</b>			
<ul style="list-style-type: none"> <li>The factory configured passwords for all accounts on this device have been set to the device serial number. Passwords are case sensitive.</li> <li>If the device is reset, the password reverts to the original password condition.</li> </ul>			
Read administrator password	<b>Esc</b> CA ←	X49 ←	
Reset (clear) administrator password	<b>Esc</b> •CA ←	Ip a• ←	
Set user password	<b>Esc</b> X49CU ←	Ip u•X49 ←	
<b>NOTE</b> A user password cannot be assigned if an administrator password does not exist. If the administrator password is cleared (removed), the user password is removed also.			
Read user password	<b>Esc</b> CU ←	X49 ←	
Reset (clear) user password	<b>Esc</b> •CU ←	Ip u• ←	
Set mail server, domain name	<b>Esc</b> X46, X50, X49CM ←	Ip m X46, X50, X49, ←	
Read mail server, domain name	<b>Esc</b> CM ←	X46, X50, X49 ←	

## Command and Response Table for IP- and SNMP-Specific SIS Commands (continued)

Command	ASCII Command (host to unit)	Response (unit to host)	Additional description
<b>IP setup commands (continued)</b>			
Set e-mail recipient	<code>Esc[X51], [X52]CR ←</code>	<code>Ipr[X51], [X52], ←</code>	This command sets the e-mail recipient. To receive e-mail notifications, you must then set the events that the switcher reports, using one or more separate Set email (EM) commands (below).
<i>Example:</i>	<code>Esc69,Jsmith@folklore.netCR ←</code>	<code>Ipr69,Jsmith@folklore.net, ←</code>	
Read e-mail recipient or target	<code>Esc[X51]CR ←</code>	<code>[X52], ←</code>	
Set e-mail events for recipient	<code>Esc[X53][X51], [X54], [X55], ØEM ←</code>	<code>Ipe[X53][X51]*[X54]*[X55]*Ø ←</code>	You must first have set an e-mail recipient for the [X51] variable, using the separate Set email recipient (CR) command above.
<i>Example:</i>	<code>EscI69,63,3,ØEM ←</code>	<code>IpeI69*63*3*Ø ←</code>	E-mail account #69 (recipient #5, JSmith), will receive fail or missing and fixed or restored messages for input 63.
Read e-mail notifications for one account (recipient)	<code>Esc[X53][X51], [X54]EM ←</code>	<code>[X55][X55][X55] ... [X55]*Ø ←</code>	
Set DHCP on or off	<code>Esc[X56]DH ←</code>	<code>Idh[X56] ←</code>	[X56]: Ø = off ( <b>default</b> ), 1 = on
Read DHCP on/off status	<code>EscDH ←</code>	<code>[X56] ←</code>	
Set serial port parameters	<code>Esc[X57]*[X58], [X59], [X60], [X61]CP ←</code>	<code>Cpn[X57]*Ccp[X58], [X59], [X60], [X61] ←</code>	
Read serial port parameters	<code>Esc[X57]CP ←</code>	<code>[X58], [X59], [X60], [X61] ←</code>	
Set serial port mode	<code>Esc[X57]*[X62]CY ←</code>	<code>Cpn[X57]*Cty[X62] ←</code>	[X62]: Ø = RS-232, 1 = RS-422,
Read serial port mode	<code>Esc[X57]CY ←</code>	<code>[X62] ←</code>	
Set verbose mode	<code>Esc[X63]CV ←</code>	<code>Vrb[X63] ←</code>	
Read verbose mode	<code>EscCV ←</code>	<code>[X63] ←</code>	
Configure current port timeout	<code>EscØ*[X64]TC ←</code>	<code>PtiØ*[X64] ←</code>	
View current port timeout	<code>EscØTC ←</code>	<code>[X64] ←</code>	
Configure global IP port timeout	<code>Esc1*[X64]TC ←</code>	<code>Pti1*[X64] ←</code>	
View global IP port timeout	<code>Esc1TC ←</code>	<code>[X64] ←</code>	
<b>SNMP setup commands</b>			
<b>NOTE:</b> See <a href="#">SNMP Settings Page</a> , on page 68. This HTML page provides introductory information about Simple Network Management Protocol (SNMP) and is the preferred method for performing the functions listed below.			
<b>Port mapping</b>			
Map SNMP port	<code>EscA[X65]PMAP ←</code>	<code>PmapA[X65] ←</code>	Assign a specific port. <b>Default:</b> 161.
Reset SNMP port to default	<code>EscA161PMAP ←</code>	<code>PmapAØØ161 ←</code>	
Disable SNMP port	<code>EscAØPMAP ←</code>	<code>PmapAØØØØØ ←</code>	Assign no port for SNMP.
View current SNMP port	<code>EscAPMAP ←</code>	<code>[X65] ←</code>	Assign a valid port to enable.
<b>Unit contact name and location</b>			
<b>NOTE:</b> No contact or location (as opposed to Not•Specified, the default value) is not a valid entry.			
Set unit contact info	<code>EscC[X66]SNMP ←</code>	<code>SnmpC*[X66] ←</code>	Set contact info to [X66].
Reset unit contact info to default	<code>EscC•SNMP ←</code>	<code>SnmpC*Not•Specified ←</code>	
View unit contact info	<code>EscCSNMP ←</code>	<code>[X66] ←</code>	
Set unit location info	<code>EscL [X66]SNMP ←</code>	<code>SnmpL*[X66] ←</code>	Set location info to [X66].
Reset unit location info to default	<code>EscL•SNMP ←</code>	<code>SnmpL*Not•Specified ←</code>	
View unit location info	<code>EscLSNMP ←</code>	<code>[X66] ←</code>	
<b>Community names</b>			
Set unit read-only community name	<code>EscP[X67]SNMP ←</code>	<code>SnmpP*[X67] ←</code>	Set read-only (public) name to [X67].
Reset read-only community name to default	<code>EscP•SNMP ←</code>	<code>SnmpP*public ←</code>	
View unit read-only name	<code>EscPSNMP ←</code>	<code>[X67] ←</code>	
Set unit read-write community name	<code>EscX[X67]SNMP ←</code>	<code>SnmpX*[X67] ←</code>	Set read-write (private) name to [X67].
Reset read-write community name to default	<code>EscX•SNMP ←</code>	<code>SnmpX*private ←</code>	

Command	ASCII Command (host to unit)	Response (unit to host)	Additional description
<b>SNMP setup commands (continued)</b>			
View unit read-write name	<code>[Esc]XSNMP ←</code>	<code>[x67]↵</code>	
<b>Access enable</b>			
Enable SNMP access and traps	<code>[Esc]E1SNMP ←</code>	<code>SnmpE*1↵</code>	
Disable SNMP access and traps	<code>[Esc]E0SNMP ←</code>	<code>SnmpE*0↵</code>	Default is disabled.
View SNMP access setting	<code>[Esc]ESNMP ←</code>	<code>[x56]↵</code>	
<b>Trap targets</b>			
Set trap target	<code>[Esc]T[x67],[x68]*[x46]*[x69]SNMP ←</code>	<code>SnmpT*[x67],[x68]*[x46]*[x69]↵</code>	
Clear trap target	<code>[Esc]T[x68]*0SNMP ←</code>	<code>SnmpT*,[x68]*0.0.0.0*0↵</code>	
View trap target	<code>[Esc]T[x68]SNMP ←</code>	<code>[x67],[x68]*[x46]*[x69]↵</code>	
<b>Trap target notifications</b>			
Set SNMP events for target	<code>[Esc][x53][x70],[x54],[x55],1EM ←</code>	<code>Ipe[x53][x70]*[x54]*[x55]*1↵</code>	Notify target <code>[x70]</code> of events defined by <code>[x53]</code> , <code>[x54]</code> , and <code>[x55]</code> .
<i>Example:</i>	<code>[Esc]F72,0,1,1EM ←</code>	<code>IpeF72*0*1*1↵</code>	Notify account #72 (SNMP target #3) upon any fan failure.
Read SNMP events for target	<code>[Esc][x53][x70],[x54]EM ←</code>	<code>[x55][x55][x55] ... [x55]*1↵</code>	

## Special Characters

The HTML language reserves certain characters for specific functions. The switcher does not accept these characters as part of preset names, name of the switcher, passwords, or locally created file names.

The following characters are not valid or not recommended:

{space (spaces **are** ok for names)} + ~ , @ = ' [ ] { } < > ' " semicolon (;)  
colon (:) | \ and ?.

# Matrix Software

This section introduces the Extron Matrix Switchers Control Program, which is available on the Extron website, including:

- [About this Program](#)
- [Installing the Software](#)
- [Using the Matrix Switchers Control Program](#)

## About this Program

The Extron Matrix Switchers Control Program and Firmware Loader communicate with the switcher via the Ethernet LAN port or a serial port to provide an easy way to set up ties and sets of ties. The program is compatible with Windows 2000, Windows XP, Windows 7, and newer operating systems. Updates to the two Extron programs can be downloaded from the Extron website.

## Software Operation via Ethernet

When a matrix switcher is connected to an Ethernet WAN or LAN, up to 200 users can operate it, locally or remotely, using the Matrix Switchers Control Program (see [Ethernet Connection](#) on page 14 for installation details).

Connection to the switcher via the Ethernet is password protected. There are two levels of password protection: administrator and user. Administrators have full access to all switching capabilities and editing functions. Users can select inputs and outputs, recall presets, and view all settings with the exception of passwords. If the same password or no password is required for logging on, all personnel log on with administrator privileges. Fields and functions that exceed user privileges are not selectable in the Matrix Switchers Control Program when the operator is logged on as a user.

**NOTE:** The factory configured passwords for all accounts on this device have been set to the device serial number. Passwords are case sensitive.

### Ethernet protocol settings

The [IP Settings / Options](#) dialog box (see [figure 22](#) on page 43) provides a location for viewing and, if the PC is connected via the RS-232 link or if you are logged on via the Ethernet port as an administrator, editing settings unique to the Ethernet interface (see [IP Settings / Options Dialog Box](#) on page 43 for more details).

## Software Operation via a Serial Port

On the FOX Matrix 14400, the two serial ports are independent of one another. A front panel Configuration port connection and a rear panel Remote RS-232/RS-422 port connection can be active at the same time.

The default serial port protocol of both ports is as follows:

- 9600 baud
- 1 stop bit
- no parity
- no flow control
- 8 data bits

The serial ports can be configured to operate at the 9600, 19200, 38400, or 115200 baud rate but Extron recommends leaving these ports at 9600 baud only (see the **Serial port parameters** SIS commands on page 34 to configure either port using an SIS command).

## Installing the Software

The Matrix Switchers Control Program and Firmware Loader are available on the Extron website. Download and install both programs as follows:

### NOTES:

- This procedural description is illustrated as using Internet Explorer. Depending on the browser you use, some steps or indications may be different.
- Steps 1 through 7, below, are also used to download firmware update packages.

1. Go to [www.extron.com](http://www.extron.com) and hover the cursor over the **Download** tab (see figure 14, ❶). The Find Software & Downloads links appear (❷).

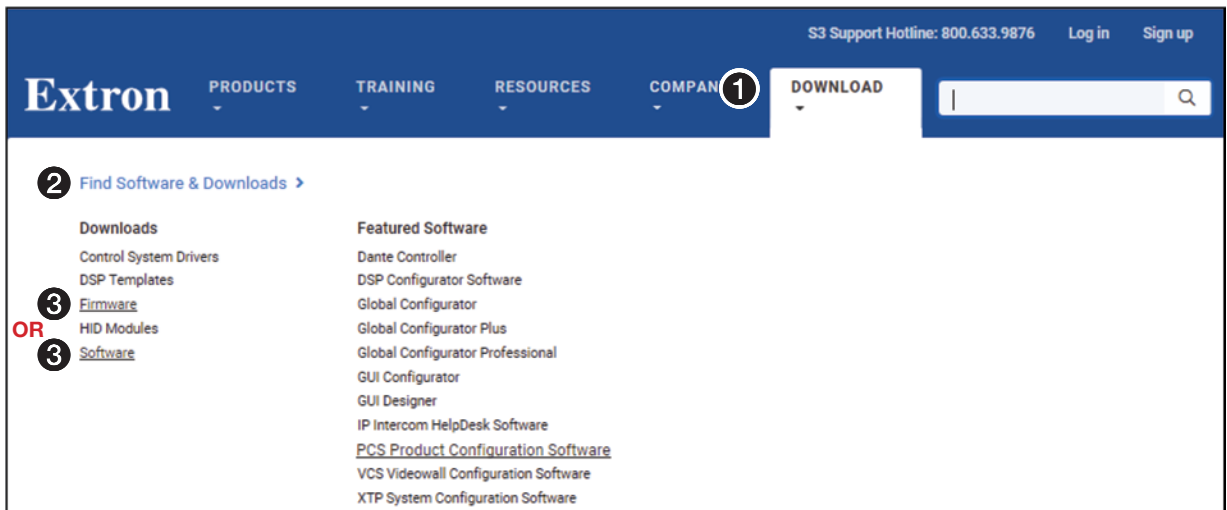

**Figure 14. Selecting the Download Tab**

2. Click the **Software** or **Firmware** link, as appropriate to the operation you are performing (❸). The main download page opens (see **figure 15** on the next page).
3. Click the desired filtering letter (see **figure 15**, ❶) to jump to the nearest page of downloads.
4. Click **Download** for the desired software or firmware package to download (❷). The Log in dialog box appears (see **figure 16** on the next page).

The screenshot shows the Extron website's Download Center. The navigation bar includes 'Extron', 'PRODUCTS', 'TRAINING', 'RESOURCES', 'COMPANY', and 'DOWNLOAD'. A search bar is on the right. The main content area is titled 'Download Center Software (83 files)'. A sidebar on the left lists categories: 'Download', 'Software', 'Control System Drivers', 'DSP Templates', 'Firmware', and 'HID Modules'. A filter bar shows letters A through Z, with 'I' highlighted and a circled '1' next to it. Below the filter bar is a 'Archives' link and a note: 'Please consult Release Notes for important compatibility information and history.' A table lists software items with columns: Description, Part Number, Version, Date, and Size. The first entry is 'Matrix Switchers' with a red 'Updated' badge, Part Number '79-520-01', Version '8.3', Date 'Sep 16, 2013', and Size '15.0 MB'. A circled '2' is next to the 'Download (Login required)' link. Below the table is a 'Release Notes' link with a PDF icon.

**Figure 15. Downloading from the Main Download Page**

The screenshot shows the Extron login dialog box. On the left, there is a sign-up section titled 'Not an insider? We invite you to become one.' It lists benefits for 'Extron Insiders get:' such as 'Product pricing', 'Certification programs', 'Software downloads, such as Global Configurator, GUI Designer, and DSP Configurator', 'Product configuration tools', 'Product and training videos', and 'Quick online repair status'. Below this is a 'Sign up' button with a circled '2'. On the right, the 'Log in to Extron.com' section asks 'If you already have an account, log in here:'. It contains an 'E-Mail' field with a circled '1', a 'Password' field, a 'Keep me logged in' checkbox with a circled '3', and a 'Log in' button with a circled '5'. Below the login fields is a 'Forgot your password?' section with an 'E-Mail' field with a circled '4' and a 'Retrieve Password' button. A note at the bottom says '(Make sure your spam filter allows e-mail from extron.com)'.

**Figure 16. Log in Dialog Box**

5. Enter the **E-Mail** address and **Password** associated with your Extron insider account (see figure 16, **1**).

**TIPS:**

- Click **Sign up** (see [figure 16](#), ② on the previous page) to obtain website credentials.
- Click **Keep me logged in** (③) to eliminate steps 4 and 5 in future downloads.
- Enter your registered e-mail address and click **Retrieve Password** (④) if you have forgotten your credentials.

6. Click **Log in** to copy the software to the computer (⑤).
7. If your browser asks you to confirm that you want to continue, click **Run** or make a similar confirmation that you want to run the installation (see [figure 17](#), ①).

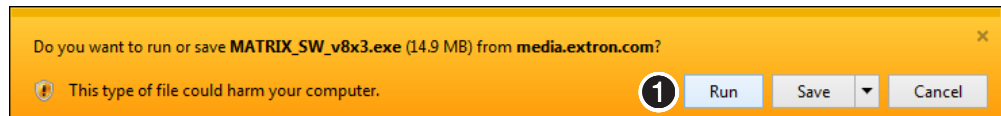

**Figure 17. Download Warning and Confirmation**

**NOTE:** Figure 17 may appear different or may not appear at all, depending on your web browser choice and its security settings.

8. **For a firmware download**, exit this procedure and return to [Updating Firmware](#) on page 48 or [Firmware Upgrade Page](#) on page 70.
9. Follow the on-screen instructions. The installation creates a `C:\Program Files\Extron\Matrix_Switchers` directory, and it places the following four icons into a group folder named “Extron Electronics\Matrix Switchers”:

**NOTE:** The folder is `C:\Program Files(x86)\ ...` for Windows 7 or Windows 8.

- MATRIX Switcher + Control Program
- MATRIX Switcher + Help
- Check for Matrix Updates
- Uninstall MATRIX Switcher

## Using the Matrix Switchers Control Program

Many items found in the Matrix Switchers Control Program are also accessible under SIS control (see [Programming Guide](#), beginning on page 20).

### Starting the Program

1. To run the Matrix Switchers Control Program, click **Start > Programs > Extron Electronics > Matrix Switchers > MATRIX Switcher + Control Pgm.**

The Comm Port Selection dialog box appears (see figure 18).

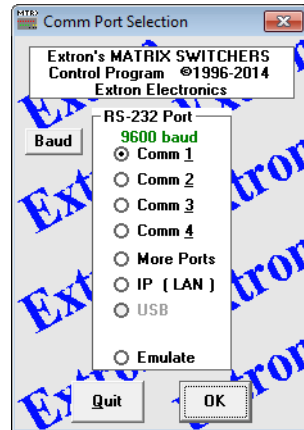

**Figure 18. Comm Port Selection Dialog Box**

2. Choose either the comm port that is connected to one of the serial ports of the switcher, **IP [LAN]**, or **Emulate**.
  - **If you selected a comm port**, check the baud rate displayed in the comm port selection dialog box.

**NOTE:** If you need to change the baud rate, click the **Baud** button and double-click the desired baud rate. The default is **9600**.

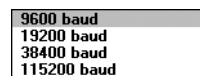

Click **OK**. The Extron Matrix Switchers Control Program window appears, displaying the current configuration of the attached matrix (see [figure 20](#) and [figure 21](#) on page 42). Proceed to step 4.

- **If you selected IP [LAN]**, click **OK** and proceed to step 3.
  - **If you selected Emulate**, click **OK** and see [Using Emulation Mode](#) on page 56.
3. **If you selected IP [LAN] in step 2**, the **IP Connection** dialog box appears (see figure 19).

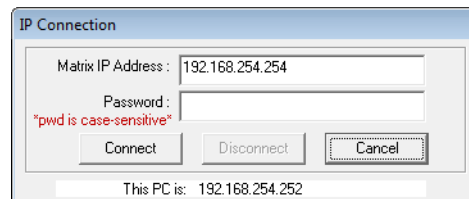

**Figure 19. IP Connection Dialog Box**

- a. Examine the **Matrix IP Address** field in the IP Connection dialog box. The field displays the last IP address entered.
  - **If the IP address is correct**, proceed to step 3b.
  - **If the address is not correct**, either click in the **Matrix IP Address** field and enter the IP address or click the scroll down button (▼) and select from among the recently used addresses. Proceed to step 3b.

**NOTE:** If the local system administrators have not changed the value, the factory-specified default, 192.168.254.254, is the value for this field.

- b. If the switcher is password protected, click in the **Password** field and enter the appropriate administrator or user password.

**NOTE:** The factory configured passwords for all accounts on this device have been set to the device serial number. Passwords are case sensitive.

- c. Click **Connect**. The Extron Matrix Switchers Control Program window appears, displaying the current configuration of the attached matrix (see **figure 20** and **figure 21** on the next page). Proceed to step 4.

- If you logged on using the administrator password or if no password was required, the program connects you to the matrix switcher with all of the administrator rights and privileges. Administrators have full access to all switching capabilities and editing functions.
  - If you logged on using the user password, the program connects you to the matrix switcher with only user capabilities.
  - If an incorrect password was entered, the program beeps and returns to the password entry display.
4. Use the Matrix Switchers Control Program controls to operate the switcher as desired.
    - To create a tie, drag an input box to one or more output boxes. To remove a tie, drag the output box to its tied input box or to the trash can.
    - To make the control program easier to use, assign a device icon to each input and output. Click on a box that represents an input or output and drag the desired icon onto the box from the icon palette that appears.
    - For quick display of information on a specific input or output device, position the pointer tool over that input or output in the control program window. The program opens a pop-up dialog box that provides details about the connection to that device (see the inset box in **figure 21** on the next page).

**NOTE:** The matrix size is so large that you need to scroll up and down to see all of the inputs and outputs.

**TIP:** You can print a map of the current configuration by clicking **File > Print Tie Map**.

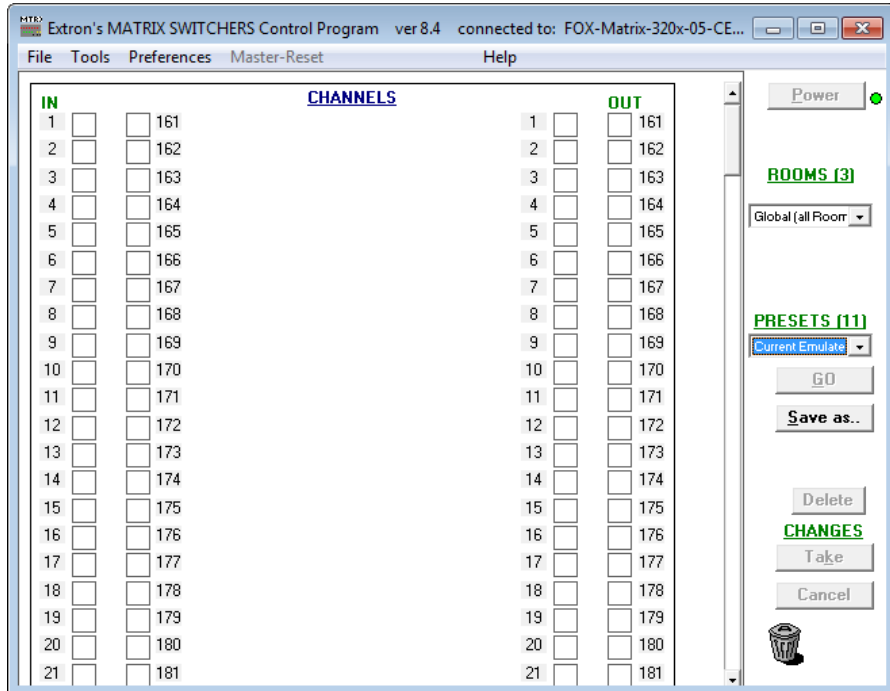

**Figure 20. Extron Matrix Switchers Control Program Window (Blank)**

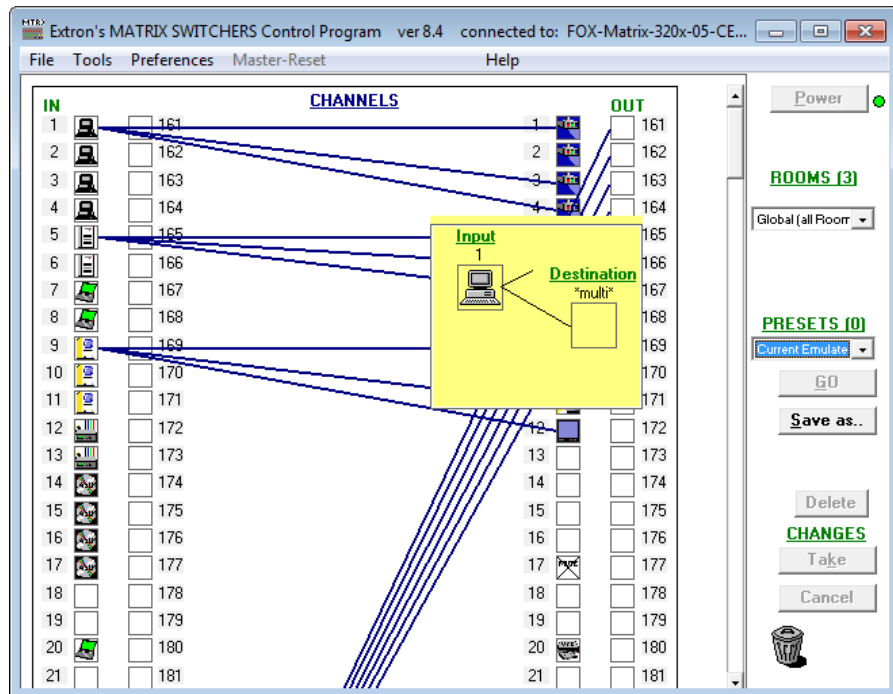

**Figure 21. Sample Matrix Switchers Control Program Window (Complete)**

## IP Settings / Options Dialog Box

The IP Settings / Options dialog box (click **Tools** > **IP options**, see figure 22) provides a location for viewing and, if connected via either serial port or if logged on via the Ethernet port as an administrator, editing settings unique to the Ethernet interface (see **Ethernet Connection** on page 82 for basic information about IP addresses). None of the fields on this screen can be edited while you are logged on as a user.

E-mail Addressee	None	Fail	Fixed	Both	Missing Input(s)	Fans	Power Supply
1 Jsmith@folklore.net	<input type="radio"/>	<input type="radio"/>	<input type="radio"/>	<input checked="" type="radio"/>	<input checked="" type="checkbox"/>	<input checked="" type="checkbox"/>	<input type="checkbox"/>
2 Pocahontas@folklore.net	<input type="radio"/>	<input checked="" type="radio"/>	<input type="radio"/>	<input type="radio"/>	<input type="checkbox"/>	<input checked="" type="checkbox"/>	<input checked="" type="checkbox"/>
3	<input type="radio"/>	<input type="radio"/>	<input type="radio"/>	<input type="radio"/>	<input type="checkbox"/>	<input type="checkbox"/>	<input type="checkbox"/>
4 Mstandish@folklore.net	<input checked="" type="radio"/>	<input type="radio"/>	<input type="radio"/>	<input type="radio"/>	<input type="checkbox"/>	<input checked="" type="checkbox"/>	<input type="checkbox"/>
5	<input type="radio"/>	<input type="radio"/>	<input type="radio"/>	<input type="radio"/>	<input type="checkbox"/>	<input type="checkbox"/>	<input type="checkbox"/>

**Figure 22. Control Program IP Setting/Options Dialog Box**

### NOTES:

- Editing variables in the IP Settings / Options dialog box while connected via the Ethernet port can immediately disconnect the user from the switcher. Extron recommends editing the settings on this screen using a serial port and protecting the Ethernet access to this screen by assigning an administrator password to qualified and knowledgeable personnel only.
- When the control program is connected to the switcher via the RS-232 link, the **Administrator Password** and **User Password** fields are not masked. If a password has been inadvertently changed to an unknown value, you can look up and change a password in this dialog box without knowing the current password.

## Address and Name fields

- The **Matrix IP Address** field contains the IP address of the connected matrix switcher. This value is encoded in the flash memory in the switcher.
- The **Gateway IP Address** field identifies the address of the gateway to the controlling PC to be used if the matrix switcher and the mail server are not on the same subnet.
- The **Subnet Mask** field is used to determine whether the matrix switcher is on the same subnet as the controlling PC when you are subnetting. For more information, see [Subnetting – A Primer](#) on page 87.
- The **Mail Server IP Address** field displays the IP address of the mail server that handles the e-mail for the facility in which the FOX matrix switcher is installed.

Valid addresses consist of four 1-, 2-, or 3-digit numeric subfields, properly called “octets,” separated by dots (periods). Each field can be numbered from 000 through 255. Leading zeroes, up to three digits total per field, are optional. Values of 256 and above are invalid.

The default addresses are as follows, but if these conflict with other equipment at your installation, you can change the addresses to any valid value:

- IP address: 192.168.254.254
- Gateway address: 0.0.0.0
- Subnet mask: 255.255.0.0

### NOTES:

- The address fields are unavailable when the **Use DHCP** checkbox is selected.
- Editing the addresses while connected via the Ethernet port can immediately disconnect the user from the FOX matrix switcher. Extron recommends editing this field using one of the serial ports and protecting the Ethernet access by assigning an administrator password to qualified and knowledgeable personnel only.

The **Extron Name/Descriptor** field contains the name of the matrix switcher. This descriptor can be changed to any valid name, up to 24 alphanumeric characters.

**NOTE:** The HTML language reserves certain characters for specific functions (see [Special Characters](#) on page 35). In the **Mail Server Domain Name** field, the @ character is acceptable only as the lead-in to the domain name (such as *@folklore.net*).

Edit any of these fields as follows:

1. Click in the desired field. The graphic cursor becomes a text cursor.
2. Edit the address or name as desired.
3. Press the <Tab> key on the keyboard or click in another field to exit the field.
4. Click the **Take** button to make the address change take effect.

## Hardware Address field

The hardware (MAC) address is hardcoded in the matrix switcher and cannot be changed.

## Use DHCP checkbox

The **Use DHCP** checkbox directs the matrix switcher to ignore any entered IP addresses and to obtain its IP address from a Dynamic Host Configuration Protocol (DHCP) server (if the network is DHCP capable). Contact the local system administrator to determine whether to use DHCP.

## Date, Time (local), and GMT (offset) fields

The **Date** field displays the current date in the Greenwich Mean Time zone.

The **Time (local)** field displays the current time in the local time zone.

The **GMT** field displays the amount of time, in hours and minutes, that the local time varies from the GMT international time reference.

**NOTE:** Rather than the following procedure, you can click the **Sync Time to PC** button to set the switcher to the internal time of your computer.

If desired, adjust any of these values as follows:

1. Click in the desired field. The field changes to an editable field appropriate to the value being changed and the graphic cursor becomes a text cursor.
  - The **Date** field becomes a set date field, with the date in the format (M)M/(D)D/YYYY. Leading zeroes are not shown. Date :
  - The **Time (local)** field becomes a set time field, with the time in the format HH:MM:SS (00:00:00 to 23:59:59). Time (local) :
  - The **GMT** field becomes a set offset field, with the offset in the format ±HH:MM (-12:00 to +14:00). GMT
2. Edit the field as desired to set the proper value. For time, remember to use 24-hour time. Leading zeroes are optional.
3. Press the <Tab> key on the keyboard or click in another field to exit the set date field.
4. Click the **Take** button to make the date change take effect.

## Sync Time to PC button

Clicking the **Sync Time to PC** button causes the computer you are operating to send its internal time to the switcher in a set time command.

## Use Daylight Saving checkbox

To turn Daylight Saving Time on and off for North America, select the **Use Daylight Saving** checkbox. When Daylight Saving Time is turned on, the switcher automatically updates its internal clock between Standard Time and Daylight Saving Time in the spring and fall on the date that the time change occurs in the country or region selected. When Daylight Saving Time is turned off, the switcher does not adjust its time reference.

**NOTE:** For Daylight Saving Time in Europe and Brazil, see the **Set Daylight Saving Time** SIS command on page 33.

## Administrator Password and User Password fields

The **Administrator Password** field displays the password required to log on to the matrix switcher via the Ethernet port with all of the rights and privileges of an administrator. The **User Password** field displays the password required to log on to the matrix switcher via the Ethernet port as a user, without all of the rights and privileges of an administrator. Passwords are case sensitive and are limited to 12 upper-case and lower-case alphanumeric characters.

Both password fields are masked with asterisks (\*\*\*\*\*) as a security measure.

### NOTES:

- The factory configured passwords for all accounts on this device have been set to the device serial number. Passwords are case sensitive.
- If the device is reset, the password reverts to the original password condition. This means the device may be password protected by the software default (usually “extron”) or there can be no password.
- On password-protected connections, there are two levels of protection: administrator and user. Administrators have full access to all switching capabilities and editing functions. Users can create ties, create and recall presets, set mutes, and view all settings with the exception of passwords.
- Editing the Administrator Password field while connected via the Ethernet port can immediately disconnect the user from the switcher. Extron recommends editing this field using either serial port and protecting the Ethernet access to this screen by assigning an administrator password to qualified and knowledgeable personnel only.
- An administrator password must be created before a user password can be created.
- The HTML language reserves certain characters for specific functions (see **Special Characters** on page 35).

Edit either password field as follows:

1. Click in the desired **Password** field. The pointer tool becomes a text cursor.
2. Edit the case-sensitive password as desired.
3. Press the <Tab> key on the keyboard or click in another field to exit the **Password** field.
4. Click the **Take** button to make the password change take effect.

## Mail Server IP Address field

The **Mail Server IP Address** field displays the IP address of the mail server that handles the e-mail for the facility in which the matrix switcher is installed. Standard IP protocol rules apply to the Mail Server IP address.

Edit this field as follows:

1. Click in the **Mail Server IP Address** field. The pointer tool becomes a text cursor.
2. Edit the IP address as desired.
3. Press the <Tab> key on the keyboard or click in another field to exit the **Mail Server IP Address** field.
4. Click the **Take** button to make the address change take effect.

## Mail Server Domain Name field

The **Mail Server Domain Name** field displays the domain name that the matrix switcher uses to log on to the e-mail server. Standard domain conventions (such as xxx.com) apply.

**NOTE:** The HTML language reserves certain characters for specific functions (see **Special Characters** on page 35). In the **Mail Server Domain Name** field, the @ character is only acceptable as the lead-in to the domain name (such as @folklore.net).

Edit this field as follows:

1. Click in the **Mail Server Domain Name** field. The pointer becomes a text cursor.
2. Edit the name as desired.
3. Press the <Tab> key on the keyboard or click in another field to exit the **Mail Server Domain Name** field.
4. Click the **Take** button to make the name change take effect.

## E-mail Addressee fields

The five **E-mail Addressee** fields permit the administrator to identify the e-mail addresses of the personnel to whom the matrix switcher e-mails notification of its failure and repair status. Figure 23 shows a typical e-mail from the switcher.

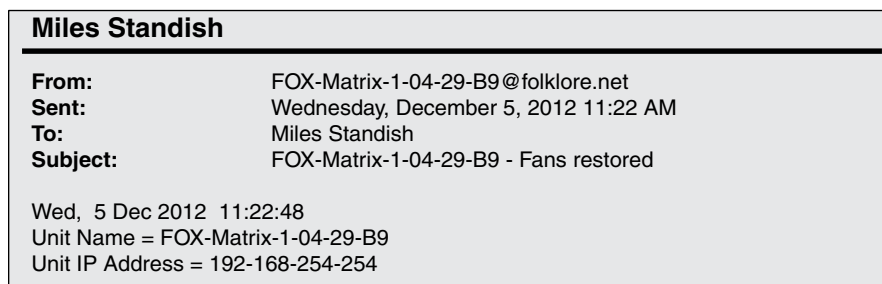

**Figure 23. Typical E-mail Message from the Switcher**

The radio buttons and checkboxes associated with each address field permit the administrator to specify e-mail requirements for each recipient.

Edit these fields and controls as follows:

1. Click in the desired **E-mail Addressee** field. The pointer becomes a text cursor.
2. Edit the e-mail address as desired. Standard e-mail address conventions apply (for example: *aaaa@xxx.com*).
3. Press the <Tab> key on the keyboard or click in another field to exit the **E-mail addressee** field.
4. In the square checkboxes associated with each addressee, select one or more options about which the addressee is to be e-mailed: **Missing Input(s)**, **Fans**, and **Power Supply**. In the floating box that contains the input numbers, select the inputs to be monitored.
5. In the round radio buttons associated with each addressee, select whether the addressee is to be e-mailed of failures, fixes, both, or not to be notified. The **None** radio button is useful for temporarily removing personnel from the e-mail list when they are unavailable, such as when travelling or on vacation.
6. If desired, click the **Send test E-mail** button to test the e-mail function.
7. Click the **Take** button to make the e-mail address changes take effect.

## Updating Firmware

The firmware upgrade utility provides a way to replace the firmware that is coded on the control board of the switcher without taking the switcher out of service.

**NOTE:** Upgrading the firmware does not overwrite the current configuration or presets.

Update the switcher firmware as follows:

1. Perform steps 1 through 7 of **Installing the Software**, on page 37, to download the firmware upgrade from the Extron website.
2. Click **Run** in the **File Download** and **Security Warning** dialog boxes (see **figure 24**, ❶ on the next page). The PC extracts the firmware update received from the Extron website and starts the Extron Installation Program to extract the firmware file.
3. Click **Next** in the **Firmware Upgrade** dialog box (❷). The program extracts the firmware files and places them in a folder identified in the InstallShield Wizard dialog box.

### ATTENTION:

- The firmware file must have an .s19 extension. Other file types can cause the switcher to stop functioning.
- Le firmware doit avoir une extension .S19. D'autres types de fichiers peuvent nuire au fonctionnement de l'émetteur.

### NOTES:

- **Note the folder to which the firmware file is saved.** When downloaded from the Extron website, the firmware is placed in a subfolder of:
  - **Windows 7, Windows 8, or Windows 10:** C:\Program Files (x86)\Extron\Firmware.
  - **Older versions:** C:\Program Files\Extron\Firmware.
- The original factory-installed firmware is permanently available on the matrix switcher. If the attempted firmware upload fails, the switcher reverts to the factory-installed firmware.



**Figure 24. Downloading Firmware Upgrade Files**

4. Click **Finish** in the Firmware Upgrade dialog box to exit the program (see figure 24, ③).
5. Connect a computer that runs the Windows operating system to a switcher serial port (see **item C**, the Remote RS-232/RS-422 port, on page 13 or **item A**, the Configuration port, on page 16) or the switcher LAN port (see **item D**, the Ethernet Port, on page 14).
6. Start the Matrix Switchers Control Program and connect to the matrix switcher (see **Using the Matrix Switcher Control Software**, steps 1 through 4, starting on page 40).

7. Click **Tools > Update** firmware. The **Select Files** dialog box appears (figure 25).

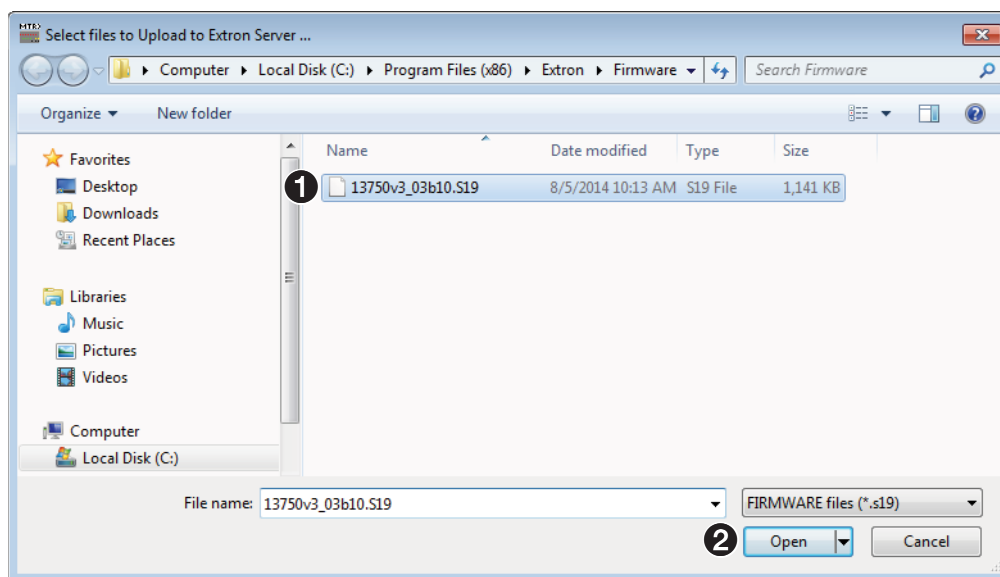

**Figure 25. Select Files Dialog Box**

8. Navigate to the folder where you saved the firmware upgrade file (see figure 25, ①). Select the file.
9. Click the **Open** button (②). The software advises you that you are about to reprogram the switcher firmware. Click **OK** to continue.

A status dialog box, which shows the progress of the upload, appears. The firmware upload to the FOX matrix switcher may take a few minutes.



## Uploading HTML Files

You can create customized HTML pages for the switcher to display. The **HTML Files List** dialog box (see figure 26), accessible via the **Tools** menu, provides a way to view the contents of the file system of the switcher and upload custom HTML pages to the switcher.

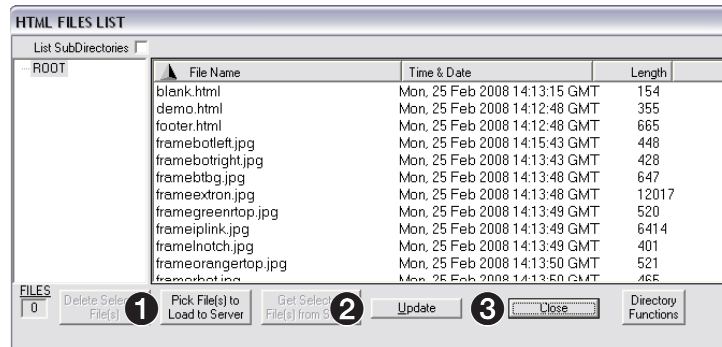

**Figure 26. HTML Files List Dialog Box**

### NOTES:

- The files listed in figure 26 are shown for example only and may not be present on your switcher.
- The **HTML Files List** dialog box is for inserting your own HTML pages. This is not the location to replace the firmware that controls all switcher operation (see [Updating Firmware](#), on page 48, to replace the firmware).
- The HTML language reserves certain characters for specific functions (see [Special Characters](#) on page 35).

Upload HTML pages as follows:

1. Connect the PC to the matrix switcher via any of the serial ports or the Ethernet port of the switcher.
2. Start the Matrix Switchers Control Program and connect to the FOX matrix switcher (see [Using the Matrix Switcher Control Software](#), steps 1 through 4, starting on page 40).
3. Click **Tools > HTML File Manager**.
4. Click the **Pick File(s) to Load to Server** button (see figure 26, ❶). An **Open File** dialog box opens.
5. Navigate to the folder where you saved the HTML files. Select the files.

### NOTES:

- To select multiple files, hold the <Ctrl> key while you select the desired files.
  - If you want one of the HTML files that you created to be the default start-up page, name the file "index.html." The FOX matrix switcher automatically looks for that file name when you first connect to it using an Internet browser.
6. Click the **Open** button. Uploading the files to the FOX matrix switcher may take a few minutes.
  7. Click the **Update** button to confirm the upload (❷).
  8. Click the **Close** button to exit the **HTML Files List** dialog box (❸).

## Windows Buttons, List boxes, and Trash Can

The buttons, list boxes, and trash can on the right side of the Matrix Switchers Control Program window perform the following functions:

- **Power** — Unavailable for FOX matrix switchers.
- **Rooms** — Displays a list of up to 10 rooms. You can select a room from the list to display it in the window.

**NOTE:** A room is a subset of outputs that the operator logically relate to each other. The FOX matrix switcher supports up to 10 rooms, each of which can consist of from 1 to 16 outputs.

- **Presets** — Displays a list of up to 64 global presets and up to 100 room presets (10 rooms x 10 presets per room). You can select a preset from the list to display it in the window and either activate it (**Go**) or delete it (**Delete**).
- **Go** — Activates the selected preset as the current configuration.
- **Save as ..** — Allows the current set of ties to be saved as a preset. Enter the preset number when prompted to do so.
- **Delete** — Allows the current preset to be deleted.
- **Changes – Take** — Allows you to execute any potential changes made to the displayed configuration.
- **Changes – Cancel** — Returns to the previous screen, undoing any changes you have made.
- **Trash can** — Drag and drop from an input or output button to the trash can to erase all ties associated with that input or output.



## Windows Menus

### File menu

- **Save MATRIX settings as ...** — Saves a complete set of up to 64 presets, rooms, room presets, and preset names plus the last active setting (preset 0), to a file. Saved settings include assigned icons and icon captions.
- **Restore MATRIX settings from ...** — Loads and activates a previously saved setting file.
- **Save This-Session's settings** — Saves the current assigned icons and icon captions.
- **Restore Last-Session's settings** — Loads the icons and icon captions that were saved during the last session. If you saved changes from the previous session to disk the last time you exited the program, the ties from that session are also loaded.
- **Select printer ...** — Selects the target printer.
- **Print tie map** — Prints the tie set that is displayed on the screen.
- **Exit** — Closes the Matrix Switchers Control Program.

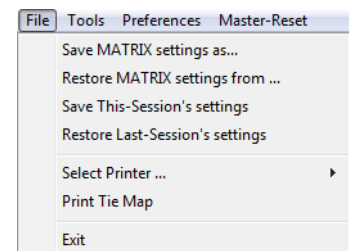

## Tools menu

- **Assign Device Icons** — Displays the complete set of input and output device icons. You can drag any of these icons to the input and output boxes.
- **Edit Device Palette** — Allows you to add your own device icon graphics.
- **Mute-Output settings** — Displays the Mute Adjust dialog box, from which you can mute each output.
- **FOX Re-clocker settings** — Displays the FOX Reclocking Rate Settings dialog box, from which you can select the reclocking rate for one or all outputs and mute and unmute the output.
- **View Input Frequencies** — Displays the Input Detection dialog box, which shows the data rates for SDI and HD-SDI inputs only. This selection is not available if no BNC 3G/HD/SD-SDI I/O boards are installed.
- **Update Firmware ...** — Allows you to replace the firmware that is coded on the control board of the switcher without taking the switcher out of service (see [Updating Firmware](#) on page 48).
- **IP Options** — Allows you to set IP options (see [IP Settings / Options Dialog Box](#) on page 43).
- **HTML file manager** — Displays a list of HTML files installed on the switcher and allows you to upload custom files from a PC connected to the switcher (see [Uploading HTML files](#) on page 51).
- **Hardware status** — Provides an overall view of the status of the matrix switcher, including the power supply voltages, the internal temperature, the Remote RS-232/RS-422 port configuration, and the installed and updated firmware status (see figure 27).

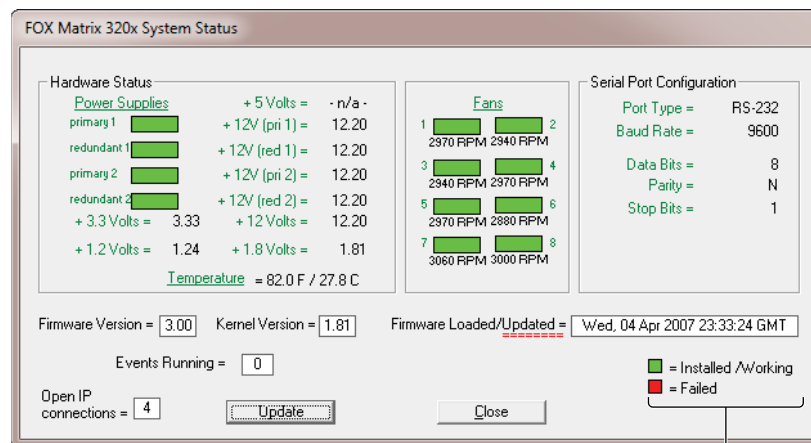
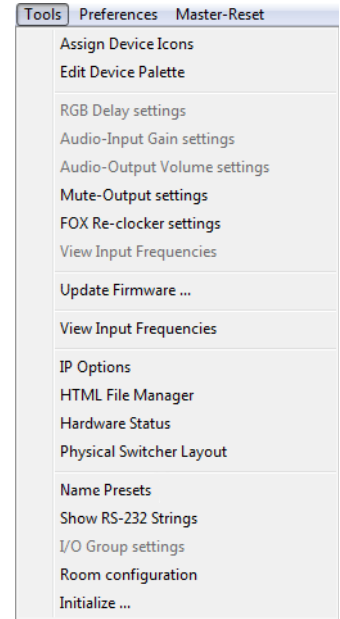

■ = Installed /Working    Proper operation.  
■ = Failed    Component has failed.

**Figure 27. Status Dialog Box**

- **Physical Switcher Layout** — Opens the FOX matrix switcher Physical Configuration dialog box (see figure 28), which displays the I/O board type installed in each slot. The Channels panel can be helpful in identifying a specific input or output. In figure 28, for example, input 49 is identified as slot 4, input transceiver 1 (4i01).

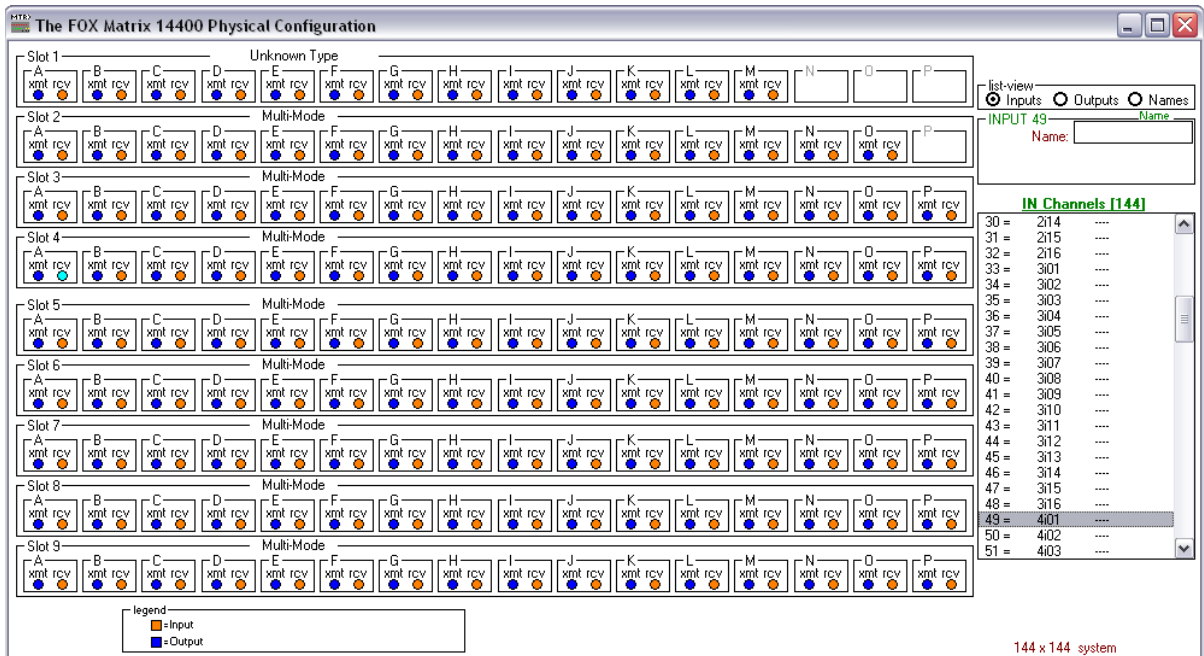

**Figure 28. Physical Configuration Dialog Box**

- **Name Presets** — Allows you to assign a name to each of the 64 global presets and 100 room presets.

**NOTE:** Preset names are limited to 12 upper- and lower-case alphanumeric characters, <space>, `_`, and `/` characters. The HTML language reserves certain characters for specific functions (see [Special Characters](#) on page 35).

- **Show RS-232 Strings** — Displays the ASCII commands that are used by the current configuration. You can refer to these for SIS programming.
- **Room configuration** — Allows you to assign outputs to or delete outputs from rooms.

**NOTE:** A *room* is a subset of outputs that are logically related to each other, as determined by the operator. The FOX matrix switcher supports up to 10 rooms, each of which can consist of from 1 to 16 outputs.

- **Initialize ...** — Initializes and clears any or all of the following: ties, presets, preset names, icon names, and icons.

## Preferences menu

- **Immediate Changes** — Causes configuration changes to take effect immediately.
- **Hold/verify Changes** — Delays implementation of configuration changes until the **Take** button is clicked.
- **Ties as Lines** — Displays ties as lines (see figure 29).



**Figure 29. Ties Shown as Lines**

- **Ties as Crosspoints** — Displays ties as a matrix of inputs and outputs (see figure 30). Ties that have been made are indicated as amber boxes. Ties that will take effect when you click the **Take** button are indicated by +. Ties that will be broken when you click the **Take** button are indicated by –.

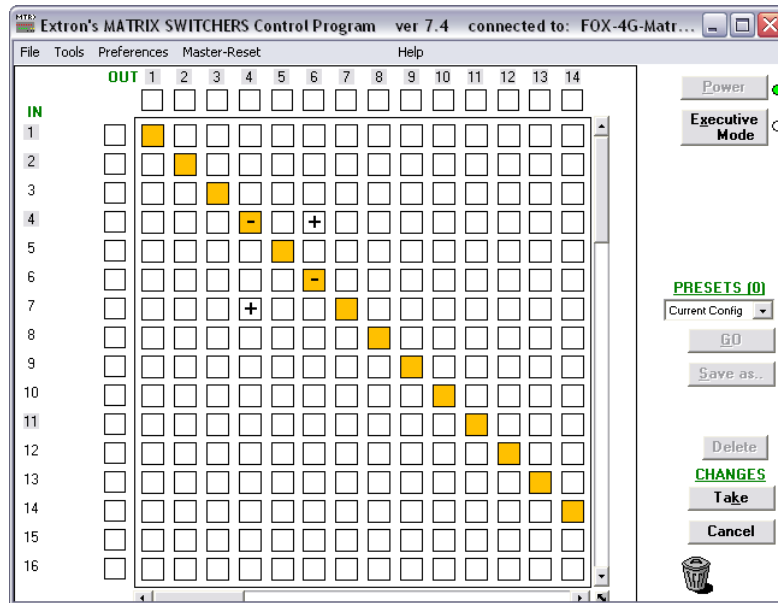



**Figure 30. Ties Shown as Crosspoints**

- **Ties as Grid** (available for FOX Matrix 320x only)— Displays ties as a grid of outputs and inputs (see figure 31) that allows you to click an output and type the desired input. Ties that have been made are indicated in black and white. Ties that will take effect or be broken when you click the **Take** button are indicated in red or gray.

--OUTS--	1	2	3	4	5	6	7	8	9	10	11	12	13	14
1 - 10	1	1	1	1	6	0	...	...	...	...	...	...	...	...

**Figure 31. Ties Shown in a Grid**

- **Link-detection options** — Allows you to set the link detection feature as follows:
  - To automatically refresh the display every 10 seconds
  - To update the display whenever you refresh the screen
  - To never sample and display the link status
- **Icons in I/O Boxes** — Erases any numbers in the I/O boxes in either the ties-as-lines display or the ties-as-boxes display (see figure 20 on page 42). You can place icons in the boxes. 
- **Numbers in I/O Boxes** — Erases any icons in the I/O boxes in either the ties-as-lines display or the ties-as-boxes display and fills each box with the associated input or output number. 

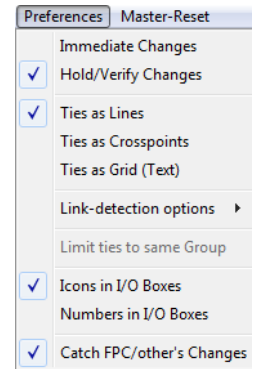

- **Catch FPC/other's Changes** — When checked, sets the switcher to report all configuration and setting changes to the serial port or Ethernet connection that turned this selection on. These reports allow the Matrix Switchers Control Program to track the changes that occur in the configuration and settings of the switcher, whether commanded via either serial port or the Ethernet port.

### Master-Reset selection

Master-Reset

Master reset performs all of the following functions:

- Clears all ties
- Clears all presets
- Clears all rooms
- Clears all output mutes

**NOTE:** Master reset does not reset the Internet protocol (IP) settings.

## Using Emulation Mode

Emulation mode allows you to set up the software without connecting the switcher. Use emulation mode as follows:

1. To run the Matrix Switchers Control Program, click **Start > Programs > Extron Electronics > Matrix Switchers > MATRIX Switcher + Control Pgm.**



The Comm Port Selection dialog box (see figure 32) appears.

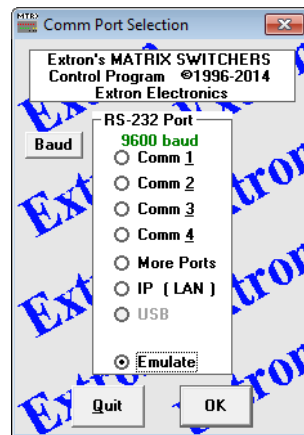

**Figure 32. Comm Port Selection Dialog Box**

2. Choose **Emulate**, and click **OK**.
3. Choose an emulation file to open, and click **OK**. The file DEMO.MTX provides a sample of a completed matrix setup. Selecting the file NEW.INI or clicking **Cancel** provides a blank setup dialog box to get you started.
4. Enter the file name under which you want to save any changes to the file, and click **OK**.

5. Select **Fiber Matrix** as the Matrix Model, **320x** or **14400** as the Default Size, and either **singlemode** or **multimode** for each board installed (see figure 33). Click **OK**.

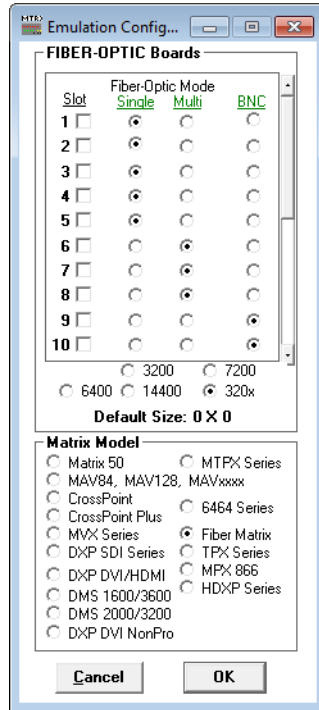

**Figure 33. Emulate Configuration Dialog Box**

6. Continue using the program as described on [page 41](#).

## Using the Help System

For information about program features, you can access the help program in any of the following ways:

- From the Extron Electronics program folder or group, double-click the **MTRX.HLP** icon (shown at right).
- From within the Matrix Switchers Control Program, click **Help > Contents** on the menu bar.
- From within the Matrix Switchers Control Program, press the keyboard <F1> key.



# HTML Operation

This section introduces using the built-in HTML pages to operate the FOX matrix switchers, including:

- **Opening the Embedded Web Pages**
- **Status Tab**
- **Configuration Tab**
- **File Management Tab**
- **Control Tab**

The switcher can be controlled and operated through its LAN port, connected via a LAN or WAN, using a web browser such as Microsoft® Internet Explorer®. The browser display of the status or operation of the switcher has the appearance of web pages. This section describes the factory-installed HTML pages, which are always available and cannot be erased or overwritten.

**NOTE:** If your Ethernet connection to the matrix switcher is unstable, try turning off the proxy server in your web browser. In Internet Explorer, click **Tools > Internet Options > Connections > LAN Settings**, uncheck the **Use a proxy server...** box, and then click **OK**.

## Opening the Embedded Web Pages

Access the switcher using HTML pages as follows:

1. Start the web browser.
2. Click in the **Address** field of the browser.
3. Enter the IP address in the **Address** field of the browser.

**NOTE:** If the local system administrators have not changed the value, the factory-specified default, 192.168.254.254, is the value for this field.

4. If you want the browser to display a page other than the default page (such as a custom page that you have uploaded), enter a slash (/) and the name of the file to open after the IP address.

### NOTES:

- The **Address** field of the browser should display the address in the following format: `<xxx.xxx.xxx.xxx>/<optional_file_name>.html`.
- The HTML language reserves certain characters for specific functions (see [Special Characters](#) on page 35).

5. Press the keyboard <Enter> key. The switcher checks to see if it is password protected.

**NOTE:** The factory configured passwords for all accounts on this device have been set to the device serial number. Passwords are case sensitive

If the switcher is not password protected, it checks and downloads the HTML pages (proceed to step 7).

If the switcher is password protected, the switcher opens the Windows Security dialog box (see figure 34).

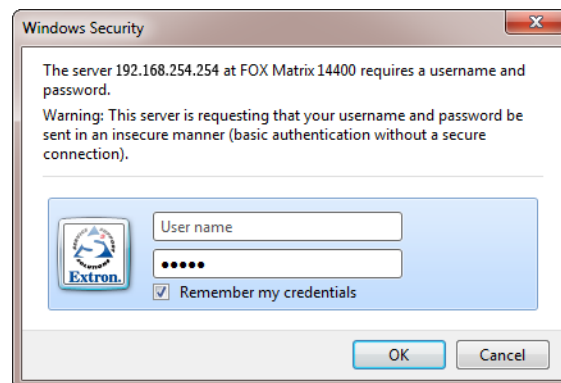

**Figure 34. Windows Security Dialog Box**

**NOTE:** A **User name** entry is not required.

6. Click in the **Password** field and type in the appropriate administrator or user password. Click the **OK** button.

7. The switcher checks several possibilities, in the following order, and then responds accordingly:
  - Does the address include a specific file name, such as 192.168.254.254/<file\_name>.html?  
**If so**, the switcher downloads that HTML page.
  - Is there a file in the memory of the switcher that is named “index.html”?  
**If so**, the switcher downloads “index.html” as the default startup page.
  - **If neither of the above conditions is true**, the switcher downloads the factory-installed default startup page, “nortxe\_index.html” (see figure 35), also known as the System Status page.

## Status Tab

### System Status Page

The System Status page (see figure 35) provides an overall view of the status of the matrix switcher, including power supply status, individual voltages, and fan status. The System Status page is the default page that the switcher downloads when you connect to the switcher. Access the System Status page from other pages by clicking the **Status** tab.

The screenshot shows the Extron Electronics System Status page. The page header includes the Extron Electronics logo and navigation tabs: Status, Configuration, File Management, and Control. The user is logged in as Admin. The main content area is titled "System Status" and contains the following information:

**System Status**

Unit Name: FOX-Matrix-1-04-6E-1D  
 Model: FOX Matrix 14400  
 Part Number: 60-1255-01      MAC Address: 00-05-A6-04-6E-1D  
 Date: 12/18/2012      Firmware Version: 2.01  
 Time: 11:05 AM      # of Connections: 003

**Operational Status**

Function	Status	Voltage
Primary Power Supply:	On/Enabled	11.94V
Redundant Power Supply:	On/Enabled	11.93V
+ 1.2 Volts:	1.18V	
+ 1.3 Volts:	1.31V	
+ 3.3 Volts:	3.27V	
+ 5 Volts:	4.98V	
+ 12 Volts:	11.74V	
Fan 1:	02860 RPM	
Fan 2:	02812 RPM	
Fan 3:	02860 RPM	
Fan 4:	02812 RPM	
Temperature:	+080.60 F / 27.00 C	

**Figure 35. System Status Page**

The System Status page periodically refreshes to reflect the latest status of the switcher components.

## Input Link Page

You can view the status of each I/O board slot on the **Input Link** page (see figure 36). Click the **Input Link** link to the left of the Status page to download the **Input Link** page. The **Input Link** automatically updates itself every 30 seconds to show the latest status of installed boards, LC connector installation, and input signal presence.

The screenshot shows the Extron Electronics web interface. The main content area is titled "Input Link" and contains a table of board slots and their input status. The table has 9 rows representing slots and 16 columns representing inputs (A through P). The status of each input is indicated by a colored circle: white for "Board Installed / No Signal", green for "Board Installed with Signal", and red for "Board Installed, no SFP". The board type for each slot is indicated by a colored background: white for "Mix Mode Board", cyan for "SDI/HD-SDI Board", yellow for "Singlemode Board", orange for "Multimode Board", and blue for "Singlemode 3G Board".

Slots / Panel Address	Inputs															
	A	B	C	D	E	F	G	H	I	J	K	L	M	N	O	P
1 1-16	Green	White	Green	Green	Green	Green	Green	Green	Green	Green	Green	Green	Green	Green	Green	Red
2 17-32	White	White	White	White	White	White	White	White	White	White	White	White	White	White	White	White
3 33-48	White	White	White	White	White	White	White	White	White	White	White	White	White	White	White	White
4 49-64	White	White	White	White	White	White	White	White	White	White	White	White	White	White	White	White
5 65-80	White	White	White	White	White	White	White	White	White	White	White	White	White	White	White	White
6 81-96	White	White	White	White	White	White	White	White	White	White	White	White	White	White	White	White
7 97-112	White	White	White	White	White	White	White	White	White	White	White	White	White	White	White	White
8 113-128	No Board															
9 129-144	White	White	White	White	White	White	White	White	White	White	White	White	White	White	White	White

Legend:

- White circle: Board Installed / No Signal
- Green circle: Board Installed with Signal
- Red circle: Board Installed, no SFP
- White background: Mix Mode Board
- Cyan background: SDI/HD-SDI Board
- Yellow background: Singlemode Board
- Orange background: Multimode Board
- Blue background: Singlemode 3G Board

Figure 36. Input Link Page

# Configuration Tab

## System Settings Page

The FOX matrix switcher downloads the **System Settings** page (see figure 37) when you click the **Configuration** tab. The screen consists of fields in which you can view and edit IP administration and system settings. You can access the **Passwords**, **Email Settings**, **SNMP Settings**, and **Firmware Upgrade** pages by clicking the appropriate link (see **Ethernet Connection** on page 82 for basic information about IP addresses and subnetting).

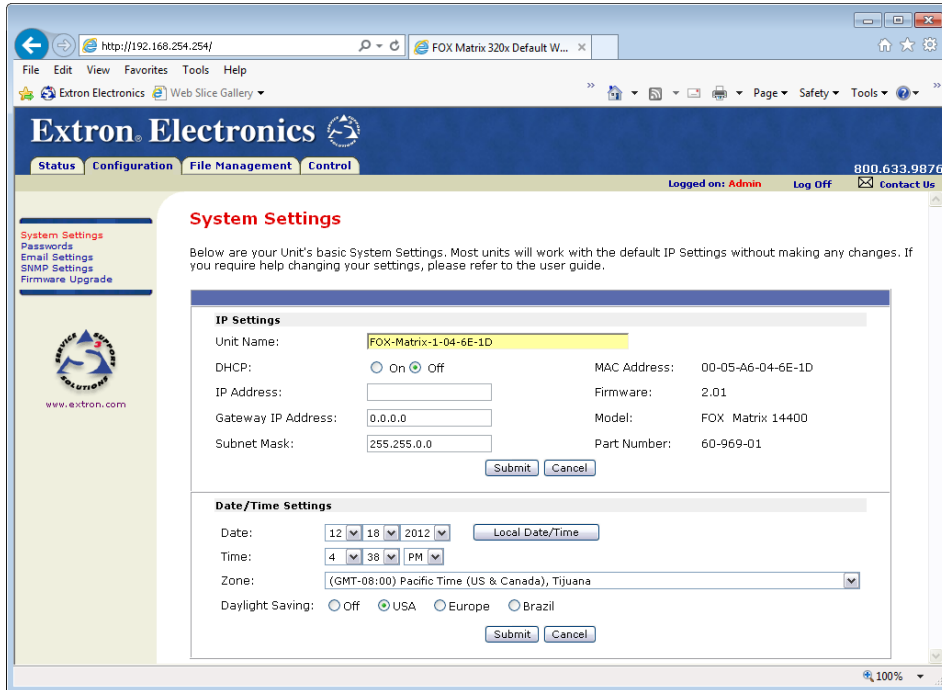

**Figure 37. System Settings Page**

On password-protected connections, there are two levels of protection: administrator and user. Administrators have full access to all switching capabilities and editing functions. Users can create ties, create and recall presets, set output mutes, and view all settings with the exception of passwords.

### IP Settings panel

The **IP Settings** panel provides a location for viewing and editing settings unique to the Ethernet interface. After editing any of the settings in this panel, click the **Submit** button at the bottom of the field.

### Unit Name field

The **Unit Name** field contains the name used as the “from” information when the switcher e-mails notification of its failed or repaired status. This name can be changed to any valid name, up to 24 alphanumeric characters.

**NOTE:** The HTML language reserves certain characters for specific functions (see **Special Characters** on page 35).

### ***DHCP radio buttons***

The **DHCP On** radio button directs the switcher to ignore any entered IP addresses and to obtain its IP address from a Dynamic Host Configuration Protocol (DHCP) server (if the network is DHCP capable). The **DHCP Off** radio button turns DHCP off. Contact the local system administrator to determine if DHCP is appropriate.

### ***IP Address field***

The **IP Address** field contains the IP address of the connected switcher. This value is encoded in the flash memory of the switcher.

Standard IP protocol consists of addresses comprised of four 1-, 2-, or 3-digit numeric subfields, properly called “octets”, separated by dots (periods). Each field can be numbered from 000 through 255. Leading zeroes, up to three digits total per field, are optional. Values of 256 and above are invalid.

The factory-installed default address is 192.168.254.254, but if this conflicts with other equipment at your installation, you can change the IP address to any valid value.

**NOTE:** IP address changes can cause conflicts with other equipment. Only local system administrators should change IP addresses.

### ***Gateway IP Address field***

The **Gateway IP Address** field identifies the address of the gateway to the mail server to be used if the switcher and the mail server are not on the same subnet.

The gateway IP address has the same validity rules as the system IP address.

### ***Subnet Mask field***

The **Subnet Mask** field is used to determine whether the switcher is on the same subnet as the mail server when you are subnetting. For more information, see **Subnetting – A Primer** on page 87.

### ***MAC Address***

The Media Access Control (MAC) Address is hardcoded in the switcher and cannot be changed.

### ***Firmware field***

The **Firmware** field identifies the installed firmware version. This field is hardcoded in the switcher and cannot be changed.

### ***Model field***

The **Model** field identifies the switcher as a FOX Matrix 320x or FOX Matrix 14400. This field is hardcoded in the switcher and cannot be changed.

### ***Part Number field***

The **Part Number** field identifies the part number of your switcher. This field is hardcoded in the switcher and cannot be changed.

## Date/Time Settings panel

The Date/Time Settings panel (see figure 38) provides a location for viewing and setting the time functions.

The screenshot shows the 'Date/Time Settings' panel. It includes a title bar, a 'Local Date/Time' button, and input fields for Date (8, 1, 2012), Time (7, 56), Zone ((GMT-08:00)), and Daylight Saving (Off, On). A dropdown menu is open for the Zone field, showing years from 2004 to 2014. A 'Submit' button and a 'Cancel' button are at the bottom right.

**Figure 38. Date/Time Settings Panel**

To sync the switcher clock to the connected PC, simply click the **Local Date/Time** button and then click the **Submit** button.

**NOTE:** Using the **Local Date/Time** button has no effect on the Zone and Daylight Savings functions.

For more complete control of the date and time settings, change the settings as follows:

1. Click the list for the variable to be changed. The adjustable variables are month, day, year, hours, minutes, AM/PM, and (time) zone. A drop-down menu appears (the year list is selected in figure 38).
2. Click and drag the slider or click the scroll up ▲ button or the scroll down ▼ button until the desired variable is visible.
3. Click the desired variable.

### NOTES:

- If setting the time, set the local time. The Zone variable allows you to then enter the offset from Greenwich Mean Time (GMT).
- The Zone field identifies the standard time zone selected and displays the amount of time, in hours and minutes, that the local time varies from the GMT international time reference.

4. Repeat steps 1 through 3 for other variables that need to be changed.
5. If appropriate, select the appropriate **Daylight Saving** radio button to turn on the daylight saving time feature for your region or nation.

**NOTE:** When Daylight Saving Time is turned on, the switcher automatically updates its internal clock between Standard Time and Daylight Saving Time in the spring and fall on the date that the time change occurs in the country or region selected. When Daylight Saving Time is turned off, the switcher does not adjust its time reference.

6. Click the **Submit** button at the bottom of the Date/Time Settings panel.

## Passwords Page

Access the **Passwords** page (see figure 39) by clicking the **Passwords** link on the **System Settings** page.

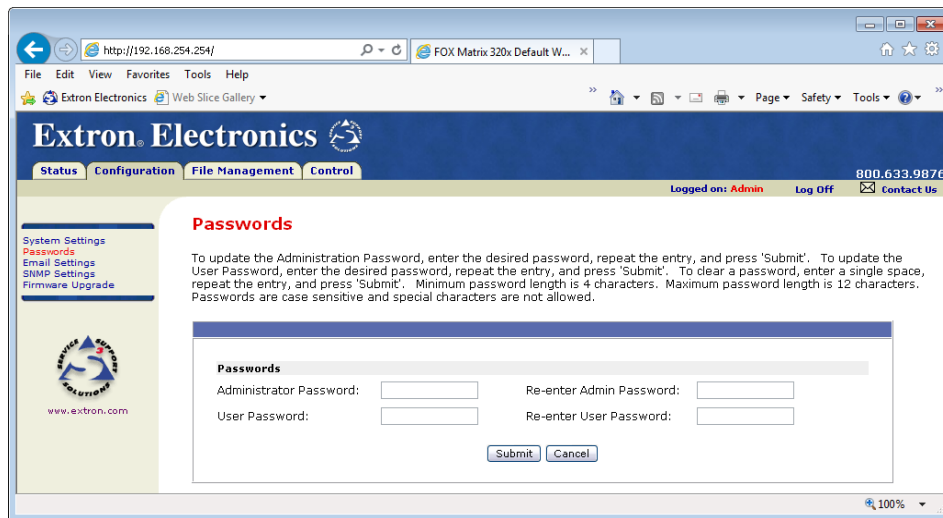

**Figure 39. Passwords Page**

### NOTES:

- The factory configured passwords for all accounts on this device have been set to the device serial number. Passwords are case sensitive.
- If the device is reset, the password reverts to the original password configuration. This means the device may be password protected by the software default (usually “extron”) or there can be no password.
- On password-protected connections, there are two levels of protection: administrator and user. Administrators have full access to all switching capabilities and editing functions. Users can create ties, create and recall presets, set mutes, and view all settings with the exception of passwords.
- If the switcher is password protected, fields on this page can be edited only by personnel logged in as administrators.
- An administrator password must be created before a user password can be created.
- The HTML language reserves certain characters for specific functions (see **Special Characters** on page 35).

The fields on the **Passwords** page are for entering and verifying administrator and user passwords. Passwords are case sensitive and are limited to 12 upper-case and lower-case alphanumeric characters. Each password must be entered twice: once in the **Password** field and then again in the **Re-enter Password** field. Characters in these fields are masked by asterisks (\*\*\*\*\*). If you do not want to password protect an access level, leave the **Password** field and the **Re-Enter Password** field blank. After entering the desired password in both fields, click the **Submit** button.

To clear an existing password so that no password is required, enter a single space character in the **Password** and **Re-enter Password** fields, and click the **Submit** button.

## Resetting a password

Reset an existing password so that no password is required as follows:

1. Clear any existing password in both the **Password** and **Re-enter Password** fields.
2. Tap the <space> bar once to enter a single ASCII space character in both the **Password** and **Re-enter Password** fields.
3. Click the **Submit** button.

## Email Settings Page

Access the **Email Settings** page (see figure 40) by clicking the **Email Settings** link on the **System Settings** page. The **Email Settings** page has fields for setting up the e-mail notification capabilities of the switcher. For the e-mail settings and for each row of the e-mail notification settings, click the **Edit** button to make the fields available for editing. The button changes to **Save**. After editing the associated settings with, click the **Save** button.

Email Address	Missing Input	Fans	Power	Email Options
1. jsmith@folklore.net	All <input type="checkbox"/>	<input checked="" type="checkbox"/>	<input type="checkbox"/>	Both Failure/Fixed <input type="button" value="Save"/>
2. Pocahontas@folklore.net	All <input type="checkbox"/>	<input type="checkbox"/>	<input checked="" type="checkbox"/>	Failure Fixed <input type="button" value="Save"/>
3.	All <input type="checkbox"/>	<input type="checkbox"/>	<input type="checkbox"/>	<input type="button" value="Save"/>
4. mstandish@folklore.net	All <input type="checkbox"/>	<input type="checkbox"/>	<input type="checkbox"/>	Suspend <input type="button" value="Save"/>
5.	All <input type="checkbox"/>	<input type="checkbox"/>	<input type="checkbox"/>	<input type="button" value="Edit"/>

**Figure 40. Email Settings Page**

### Mail IP Address field

The **Mail IP Address** field displays the IP address of the e-mail server for the facility in which the FOX matrix switcher is installed. Standard IP protocol rules apply to the **Mail IP** address field.

### Domain Name field

The **Domain Name** field displays the domain name that the FOX matrix switcher uses to log on to the e-mail server. Standard domain name conventions (for example: xxx.com) apply.

**NOTE:** The HTML language reserves certain characters for specific functions (see **Special Characters** on page 35). The @ character is acceptable only as the lead-in to the domain name (such as @folklore.net).

### Setting up SMTP authorization

If desired, set the FOX matrix switcher to require SMTP authorization before accepting any e-mail as follows:

1. Click **Edit**. The button changes to **Save**.
2. Select the **SMTP Authorization Required** checkbox, located below the **Domain Name** field. This enables the **User Name** and **Password** fields below the checkbox.
3. Enter a user name and a password in the **User Name** and **Password** fields. For the FOX matrix switcher to accept their e-mail messages, senders must enter the user name and password.

#### NOTES:

- For the user name, any combination of letters, numerals, spaces, and symbols except the comma (,) and the single and double quotation marks (' and ") are valid. For the password, all characters except the comma are valid. The user name and password can each be from 1 to 30 characters.
- Both a user name and a password must be specified.
- The factory configured passwords for all accounts on this device have been set to the device serial number. Passwords are case sensitive.

4. Click **Save** to save the user name and password.

### Deselecting SMTP authorization

Remove SMTP authorization as follows:

1. Click **Edit**. The button changes to **Save**.
2. Click (deselect) the **SMTP Authorization Required** checkbox.
3. Click **Save**.

### Email Address fields

The five **Email Address** fields identify the e-mail addresses of the personnel to whom the FOX matrix switcher e-mails notification of its failure and repair status. Standard e-mail address conventions (aaaaa@xxx.com) apply.

The checkboxes and list boxes associated with each address field permit you to specify specific criteria under which the switcher will e-mail recipients.

- In the associated **Missing Input** list boxes, select the inputs to monitor for presence or absence of a signal.
- Check the **Fans** and **Power** boxes to monitor the fans and power supplies.
- In the associated **Email Options** list, select whether the recipient is to be e-mailed about failures, fixes, both, not notified, or to be removed from the e-mail list. The **Suspend** option is useful for temporarily removing personnel from the e-mail list when they are unavailable, such as when travelling or on vacation.
- Deleting an e-mail addressee and clicking the **Submit** button removes the recipient from e-mail notification completely.

## SNMP Settings Page

### NOTES:

- Simple Network Management Protocol (SNMP) is an internet-standard protocol for IT personnel to manage devices on an IP network. It is not the intent of this guide to define SNMP further than this and this section is intended for users who are familiar with SNMP protocol.
- The matrix switcher can report alarm events via an SNMP trap, providing simple integration with network management systems (NMS).
- When communicating using SNMP and generating SNMP traps (alarms and notifications), the matrix switcher complies with the requirements of SNMP v2c.
- **IT personnel** — Contact the S3 Sales & Technical Support Hotline to get all Extron-specific Management Information Bases (MIBs). See the contact numbers listed on the Extron [webpage](#) for the office nearest you.

Reach the **SNMP Settings** page (see figure 41) by clicking the **SNMP Settings** link on the **System Settings** page. The **SNMP Settings** page has fields for establishing the general SNMP settings and fields to establish SNMP monitoring and optional traps.

The screenshot displays the Extron Electronics web interface for the SNMP Settings page. The browser address bar shows the URL http://192.168.254.254/. The page header includes the Extron Electronics logo and navigation tabs for Status, Configuration, File Management, and Control. The user is logged in as Admin.

The main content area is titled "SNMP Settings" and contains the following sections:

- SNMP General Settings:** Includes checkboxes for "SNMP Enabled" (checked), text fields for "SNMP (rd) Community Name" (public), "SNMP (wrt) Community Name" (private), "Contact Name" (John Smith), "SNMP Port" (00161), and "Location" (Virginia Colony). There are "Submit" and "Cancel" buttons.
- SNMP Manager (Trap Target) Table:** A table with columns for "Missing Input", "Fans", "Power", and "Notification Options". It lists three trap targets with their respective IP addresses, community names, and input selections.

SNMP Manager (Trap Target)	Missing Input	Fans	Power	Notification Options
IP Address 1: 192.168.254.25 Community Name 1: public	All <input checked="" type="checkbox"/>	<input checked="" type="checkbox"/>	<input checked="" type="checkbox"/>	Both Failure/Fixed <input type="button" value="Edit"/>
IP Address 2: 192.168.254.26 Community Name 2: public	All <input type="checkbox"/>	<input checked="" type="checkbox"/>	<input checked="" type="checkbox"/>	Suspend <input type="button" value="Edit"/>
IP Address 3: 192.168.254.27 Community Name 3: private	All <input checked="" type="checkbox"/>	<input type="checkbox"/>	<input checked="" type="checkbox"/>	Delete SNMP Target <input type="button" value="Edit"/> Failure Occurs Failure Fixed Both Failure/Fixed Suspend

Figure 41. SNMP Settings Page

### SNMP General Settings fields

To edit the **SNMP General Settings** fields, ensure that the **SNMP Enabled** checkbox is selected (SNMP is disabled by default). Click the **Submit** button to save all changes or the **Cancel** button to abandon changes.

**SNMP Community Name fields** — The two names are similar to passwords, granting public, read-only [SNMP (rd)] and private, read-write access [SNMP (wrt)] to the NMS. The default names are **public** and **private**.

**Contact Name and Location fields** — The two fields add optional information as to the location of the NMS. By default, **Not Specified** is assigned to the **Name** and **Location** fields.

**SNMP Port field** — This field identifies the port that the NMS uses to communicate with the switcher and should only be changed by IT personnel. The default port is **161**.

### SNMP Manager (Trap Target) fields

To edit each row of the **SNMP Manager (Trap Target)** settings, click the **Edit** button to make the fields available for editing. The button changes to **Save**. After editing the associated settings, click the **Save** button.

The three **IP Address** fields identify up to three NMS targets to receive trap notifications of the switcher failure and repair status or a mix of trap types to the same target.

The checkboxes and list boxes associated with each IP address field permit the operator to specify specific criteria under which the switcher sends trap notifications.

- In the associated **Missing Input** list boxes, select the inputs to trap the presence or absence of a signal.
- Check the **Fans** and **Power** boxes to trap the fans and power supplies.
- In the associated **Notification Options** list, select whether to notify the target of failures, fixes, both, not notified, or to remove the target from trap list (select **Delete SNMP Target**). The **Suspend** option is useful for temporarily removing NMS stations from the notification list when they are unavailable.

## Firmware Upgrade Page

The **Firmware Upgrade** (see figure 42) page provides another way to replace the firmware that is coded on the control board of the switcher without taking the switcher out of service. Access the page by clicking the **Firmware Upgrade** link on the **System Settings** page.

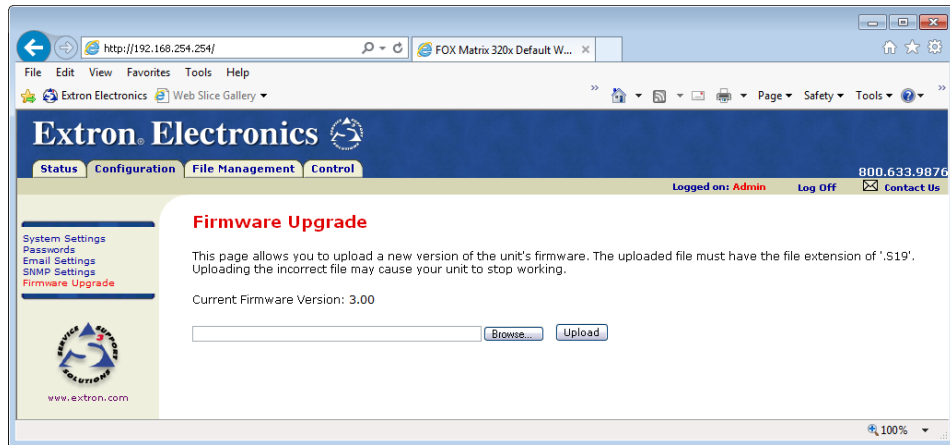
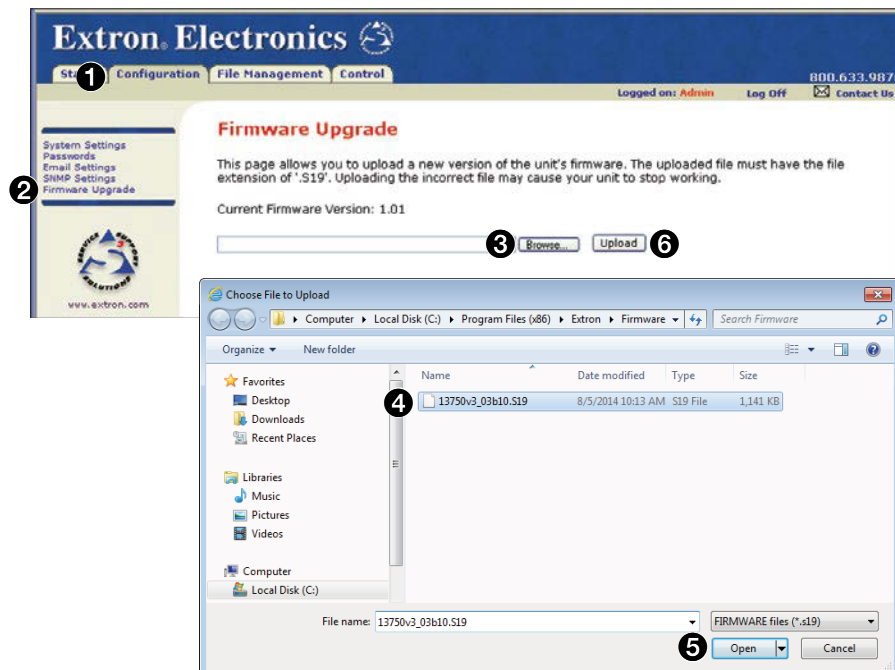

**Figure 42. Firmware Upgrade Page**

Update the switcher firmware as follows:

**NOTE:** The Firmware Upgrade page is only for replacing the firmware that controls all switcher operation. To insert your own custom HTML pages, see **File Management Page**, on the next page.

1. Perform steps 1 through 5 of **Installing the Software**, on page 37, to download the firmware upgrade from the Extron website.
2. Connect the PC to the FOX matrix switcher via the LAN port of the switcher.
3. Access the FOX matrix switcher using HTML pages.
4. Click the **Configuration** tab (see figure 43, ❶).



**Figure 43. Firmware Upgrade**

5. Click the **Firmware Upgrade** link (see **figure 43** on the previous page, **2**).
6. Click the **Browse** button (**3**). A Choose File to Upload dialog box appears.
7. Navigate to the folder where you saved the firmware upgrade file and select it (**4**).

**ATTENTION:**

- The firmware file must have an .s19 extension. Other file types can cause the switcher to stop functioning.
- Le firmware doit avoir une extension .S19. D'autres types de fichiers peuvent nuire au fonctionnement de l'émetteur.

**NOTES:**

- When downloaded from the website, the firmware is placed in a subfolder of:
  - **Windows 7 or Windows 8:** C:\Program Files (x86)\Extron\Firmware.
  - **Older versions:** C:\Program Files\Extron\Firmware.
- The original firmware is permanently available on the switcher. If the attempted firmware upload fails, the switcher reverts to the factory-installed firmware.

8. Click the **Open** button (**5**).
9. Click the **Upload** button (**6**). The firmware upload may take a few minutes.

## File Management Tab

### File Management Page

To delete files such as HTML pages from the switcher or to upload your own files to the switcher, click the **File Management** tab. The switcher downloads the **File Management** HTML page (see figure 44).

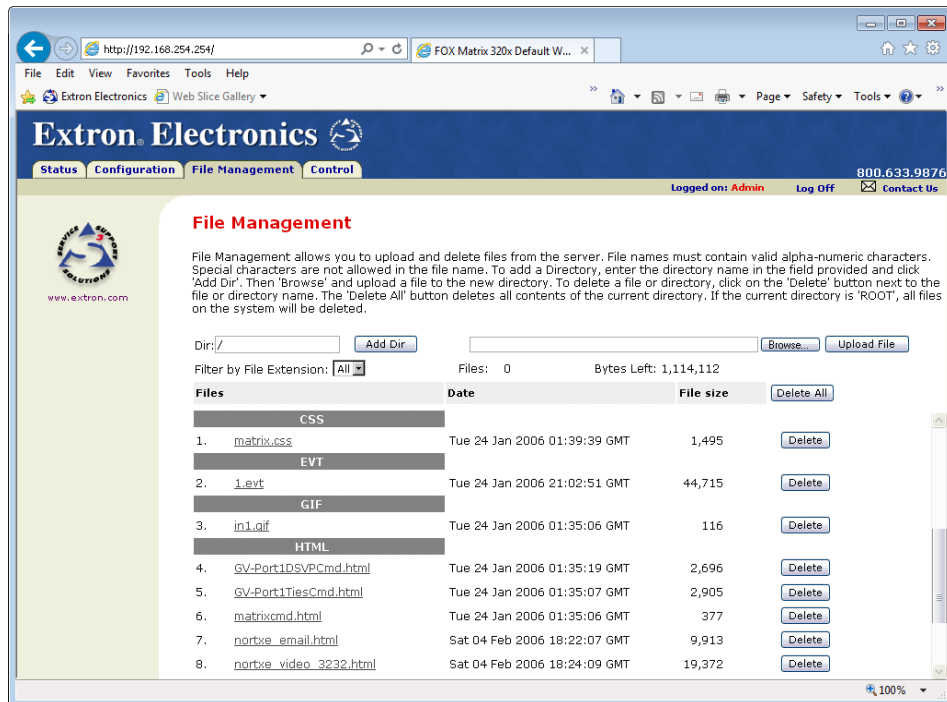

**Figure 44. File Management Page**

**NOTE:** Figure 44 is an example only. Files shown may not be present on your switcher.

To delete a file, click the **Delete** button associated with that file.

Upload your own files as follows:

**NOTE:** The HTML language reserves certain characters for specific functions (see **Special Characters** on page 35).

1. Click the **Browse** button.
2. Browse through your system and select the desired file or files.

**NOTE:** If you want one of the pages that you create and upload to be the default startup page, name that file "index.html".

3. Click the **Upload File** button. The file or files that you selected appear in the list.

## Control Tab

### Set and View Ties Page

You can create ties on the **Set and View Ties** page (see figure 45). Access the **Set and View Ties** page by clicking the **Control** tab.

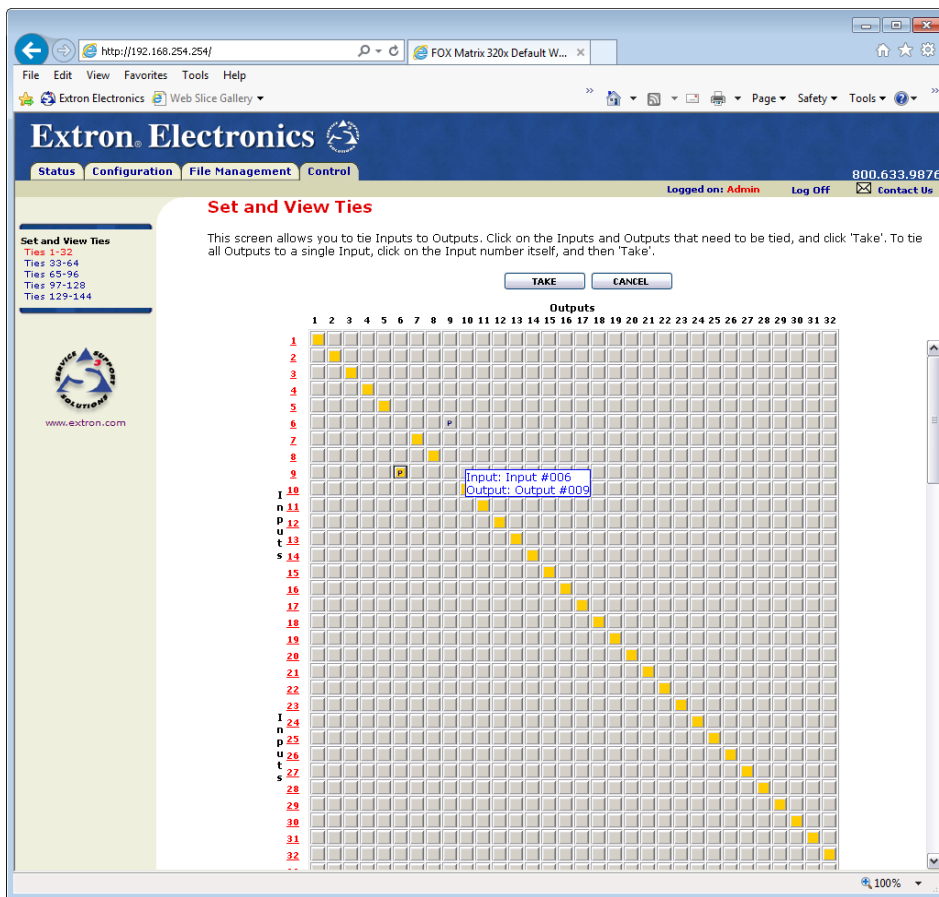

**Figure 45. Set and View Ties Page**

The page consists of a matrix of input (rows) and output (columns) buttons of two colors:

- The **amber** buttons indicate **ties**.
- The **gray** buttons indicate **no ties**.

**TIP:** If you lose track of the input and output associated with a specific button, let the mouse pointer rest over the button for a moment. As shown on **figure 45** on the previous page, a field pops up that identifies the input and output numbers for that button.

### Creating or deleting a tie

Make or break a tie as follows:

1. Move the mouse over the matrix of input and output selection buttons. Click a button to:
  - Create a pending tie (if a tie does not exist) of the input and output associated with that button.
  - Create a pending untie (if a tie exists) of the input and output associated with that button.

A “P” (for pending) appears in the button.

#### NOTES:

- Because of command length limitations in the browser, you can make a maximum of 30 connections with a single **Take** command (step 2).
- To tie an input to all outputs, click the input number for that input.

2. Click the **Take** button to make the configuration changes or the **Cancel** button to abandon the configuration changes.

# Maintenance and Modifications

This section covers corrective maintenance and modifying the FOX matrix switchers, including:

- **Mounting the Switcher**
- **Battery and Power Precautions**
- **Removing and Installing an I/O Board or Blank Panel**
- **Removing and Installing a Power Supply Module**
- **Removing and Installing a Fan Module**

## **ATTENTION:**

- Installation and service must be performed by authorized personnel only.
- L'installation et la maintenance du système doivent être exclusivement effectuées par le personnel autorisé.

## Mounting the Switcher

The FOX Matrix 320x is housed in a rack-mountable, 17U high metal enclosure with mounting flanges for standard 19-inch wide racks. The FOX Matrix 14400 is in an 8U high enclosure.

## UL Guidelines

The following Underwriters Laboratories (UL) guidelines pertain to the installation of the matrix switcher into a rack.

- **Elevated operating ambient temperature** — If the equipment is installed in a closed or multi-unit rack assembly, the operating ambient temperature of the rack environment may be greater than room ambient. Therefore, consider installing the equipment in an environment compatible with the maximum ambient temperature specified by Extron (T<sub>ma</sub> = +32 to +122 °F [0 to +50 °C]).
- **Reduced air flow** — Installation of the equipment in a rack should be such that the amount of air flow required for safe operation of the equipment is not compromised.
- **Mechanical loading** — Mount the equipment in the rack so that uneven mechanical loading does not create a hazardous condition.
- **Circuit overloading** — Consider the connection of the equipment to the supply circuit and the effect that overloading of the circuits might have on overcurrent protection and supply wiring. Use appropriate consideration of equipment nameplate ratings when addressing this concern.
- **Reliable earthing (grounding)** — Reliable earthing of rack-mounted equipment should be maintained. Particular attention should be given to supply connections other than direct connections to the branch circuit (such as the use of power strips).

## Mounting Instructions

If desired, rack mount the switcher as follows:

1. Insert the unit into the rack, aligning the mounting bracket holes with those in the rack.
2. Secure the switcher to the rack using the supplied bolts.

## Battery and Power Precautions

The matrix switcher is provided with a permanently installed (factory-soldered in place) lithium battery. The battery maintains the real time clock in the event of power failure or extended storage periods and does not affect the normal operation of the switcher. If the battery becomes ineffective, return the switcher to Extron for repair.

 **WARNING:** There is a danger of explosion if the battery is incorrectly replaced. Do not attempt to remove or replace the internal battery.

**AVERTISSEMENT :** Si la pile est mal remplacée, il y a un risque d'explosion. N'essayez pas de retirer ou de remplacer la batterie interne.

### ATTENTION:

- This unit uses double pole/neutral fusing. Do not operate the equipment with only one power supply cord connected.
- Cette unité utilise double pôles/fusion neutre. N'utilisez pas l'équipement avec seulement un cordon d'alimentation connecté.

## Removing and Installing an I/O Board or Blank Panel

 **WARNING:** The FOX matrix switchers fiber optic I/O boards output continuous invisible light (Class 1 rated), which may be harmful to the eyes; use with caution.

**AVERTISSEMENT :** Le grilles de commutation de la gamme FOX cartes d'entrée/sortie fibre optique émet une lumière invisible en continu (conforme à la classe 1) qui peut être dangereux pour les yeux, à utiliser avec précaution.

- **Do not look** into the fiber optic cable connectors or into the fiber optic cables themselves.
- Ne regardez pas dans les connecteurs de câble fibre optique sur le panneau arrière ou dans les câbles fibre optique eux-mêmes.
- Plug the attached dust cap into the optical transceiver when the fiber optic cable is unplugged.
- Branchez la protection contre la poussière dans l'ensemble émetteur/récepteur lorsque le câble fibre optique est débranché.

**NOTES:**

- As factory configured, the fiber optic I/O boards are either 100 percent singlemode or 100 percent multimode, but you can remove a fiber optic transceiver module (one input and one output) of one transmission mode and replace it with a module of the other transmission mode.  
You can mix transmission mode transceiver modules on a fiber optic I/O board, provided that you ensure that each fiber cable and connected devices are the appropriate transmission mode for the transceiver module. Typically, singlemode fiber cable has a yellow jacket and multimode cable has an orange or aqua jacket.
- For proper cooling and air flow, boards or blank panels should be installed in all locations during normal switcher operations.

As shown in figure 46, each I/O board is identified by the input and output numbers supported by the board position, which are printed on the side of each fan module (1 - 16, 17 - 32, and so on). The transceiver modules on fiber optic I/O boards are identified as A through P.

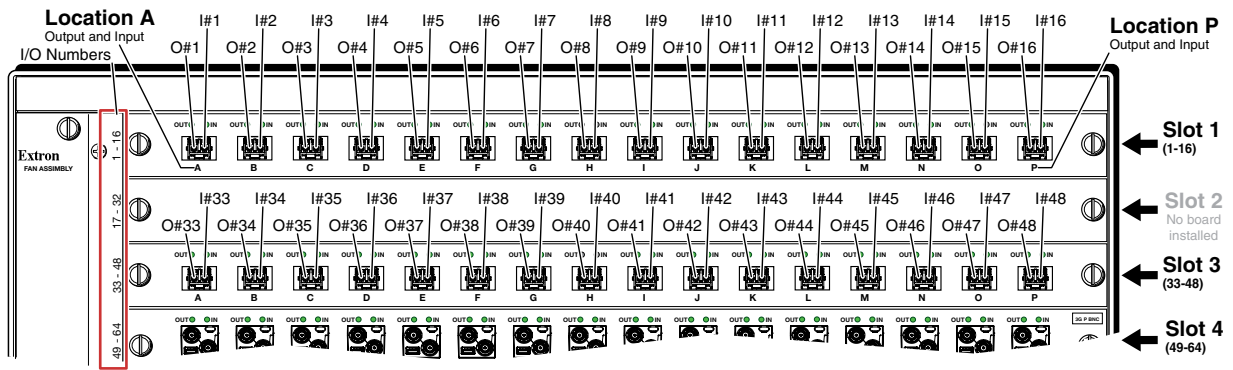

**Figure 46. Arrangement of Inputs and Outputs on the I/O Boards**

Locations A through P correspond to the transceiver modules. Each module, numbered from left to right, includes one of the outputs and one of the inputs supported by the board. (For example, the input and output numbers supported by the I/O board in location 33 - 48 [slot 3] are as follows: A = 33, B = 34, C = 35, D = 36, E = 37, F = 38, G = 39, H = 40, I = 41, J = 42, K = 43, L = 44, M = 45, N = 46, O = 47, and P = 48.)

**NOTE:** The output on the transceiver module is to the *left* of the input.

Slot	Inputs and outputs	Slot	Inputs and outputs
1	1 through 16	11*	161 through 176
2	17 through 32	12*	177 through 192
3	33 through 48	13*	193 through 208
4	49 through 64	14*	209 through 224
5	65 through 80	15*	225 through 240
6	81 through 96	16*	241 through 256
7	97 through 112	17*	257 through 272
8	113 through 128	18*	273 through 288
9	129 through 144	19*	289 through 304
10*	145 through 160	20*	305 through 320

\* FOX Matrix 320x only

**ATTENTION:**

- Do not touch the electronic components or the connectors on the backplane or on the circuit boards without being electrically grounded. Handle circuit boards by their edges only. ESD can damage circuits, even if you cannot feel, see, or hear it.
- Ne pas toucher les composants électroniques ou les connecteurs sur la carte mère ou sur les circuits imprimés sans être électriquement relié à la terre. Manipuler les circuits imprimés en les tenant seulement par leurs bords. Cela pourrait endommager le commutation de la gamme FOX.

**NOTE:** The I/O boards are hot-swappable. You do not need to power down the switcher to remove or install an I/O board.

## Removing an I/O Board or Blank Panel

Remove an I/O board or blank panel as follows:

1. **For an I/O board**, disconnect any connected cables.
2. Rotate the left and right knurled knobs to completely loosen the captive thumbscrews.
3. Gently pull on the screws to loosen the board or panel from the backplane.
4. Slide the board or panel out of the chassis (see figure 47) and place it on an anti-static surface or in an anti-static container.

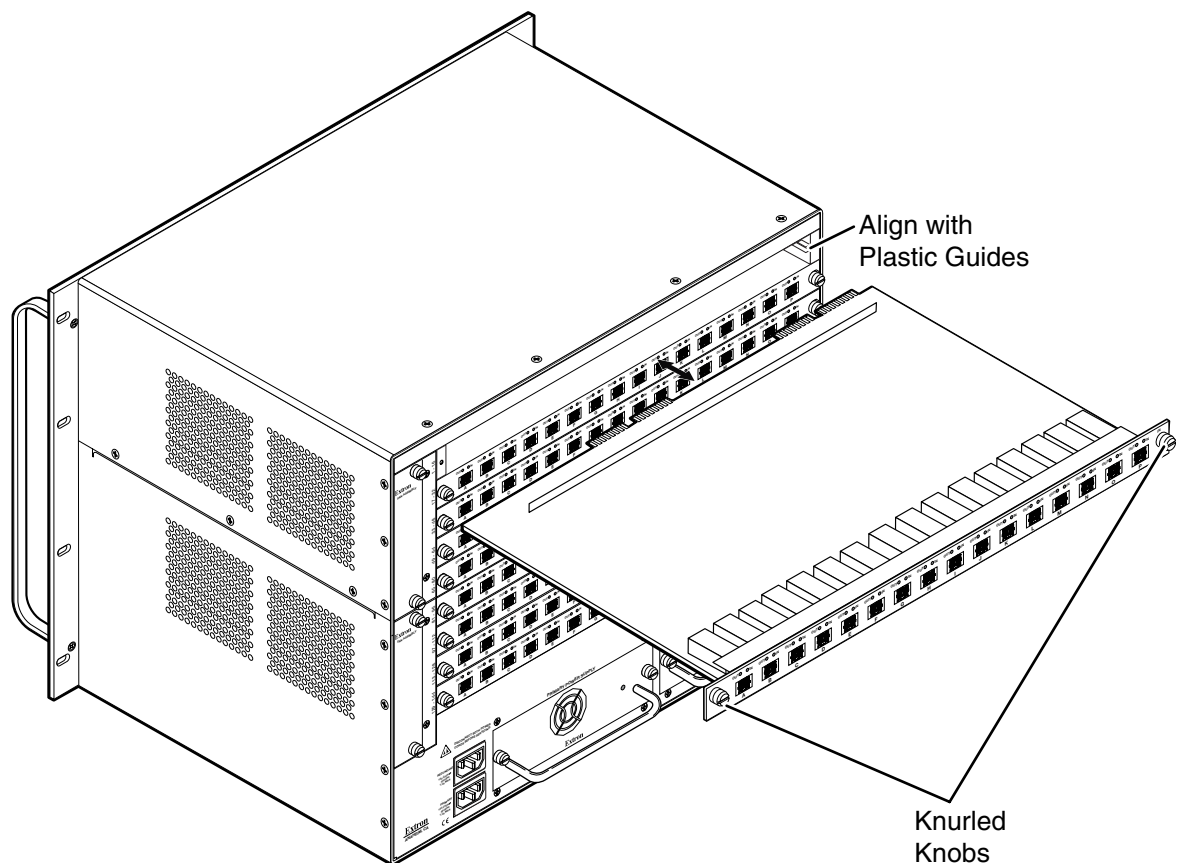

**Figure 47.** I/O Board Replacement

## Installing an I/O Board or Blank Panel

Install an I/O board or blank panel as follows:

**NOTE:** Captive thumbscrews must be tightened with a screwdriver after both initial installation and subsequent replacement of an I/O board or back panel.

1. **For an I/O board**, orient the board to be installed so that transceiver module A (**fiber board**) or input BNC A (**SDI/HD-SDI board**) is on the left and P is on the right.
2. **For an I/O board**, align the board with the left and right chassis guides (see **figure 47** on the previous page).
3. Gently slide the board or blank panel into the enclosure. **For an I/O board**, slide the board toward the front panel until it meets resistance.
4. Gently seat the board or panel in the backplane.
5. Use a screwdriver to tighten the left and right captive thumbscrews to secure the board or panel in place.

## Removing and Installing a Power Supply Module

The power supply modules are identical. Each power supply module has a 2-color LED that indicates the status of the power supply outputs. If the LED is lit green, the power supply is operating normally. If the LED is lit red, the supply has failed and should be replaced at the earliest opportunity.

**NOTE:** The power supply modules are hot-swappable. Any power supply can be removed without powering down the switcher.

### Removing a Power Supply Module

Remove a power supply module as follows:

1. Rotate the left and right knurled knobs to completely loosen the captive thumbscrews.
2. Gently pull on the handle to loosen the power supply from the backplane (see **figure 48** on the next page).

**NOTE:** Figure 48 shows a FOX Matrix 14400. The FOX Matrix 320x is similar, but has four power supply modules that are vertically mounted.

3. Slide the power supply out of the chassis.

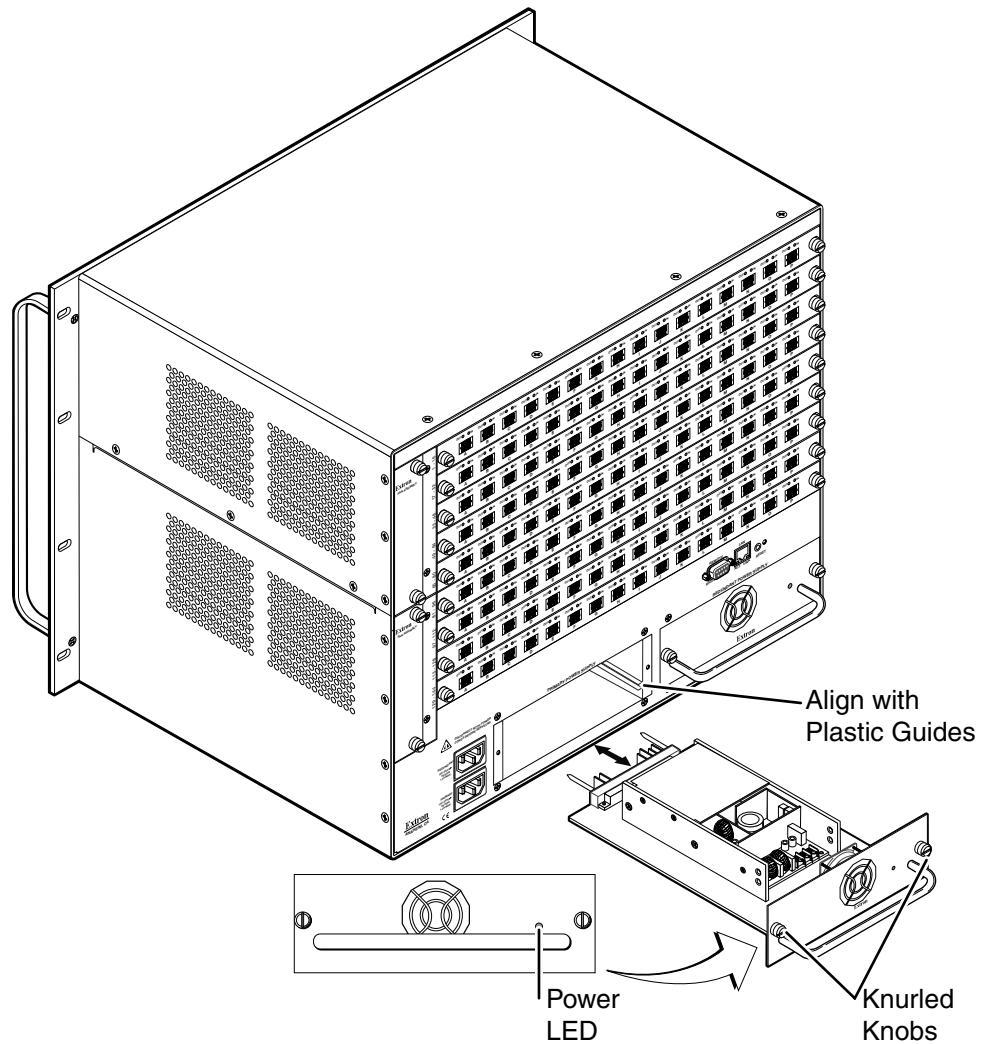

**Figure 48. Power Supply Replacement, FOX Matrix 14400**

## Installing a Power Supply Module

### NOTES:

- The power supply modules are hot-swappable. You do not need to power down the switcher to install a power supply.
- Captive thumbscrews must be tightened with a screwdriver after both initial installation and subsequent replacement of a power supply module.

Install a power supply module as follows:

1. Orient the power supply module to be installed with the LED to the right.
2. Align the flanges on the power supply module with the left and right power supply guides (see figure 48).
3. Gently slide the power supply module into the enclosure until the power supply meets resistance.
4. Gently seat the power supply in the backplane.
5. Use a screwdriver to tighten the left and right captive thumbscrews to secure the power supply in place.

## Removing and Installing a Fan Module

The FOX Matrix 320x has four fan modules and the FOX Matrix 14400 has two fan modules. The fan modules for each model are identical. If a fan fails, it should be replaced at the earliest opportunity.

### Removing a Fan Module

**NOTE:** The fans modules are hot-swappable. Either fan can be removed or installed without powering down the switcher.

Remove a fan module as follows:

1. Remove and retain the two screws that secure the row identification plate to the fan (see figure 49). Retain the plate.

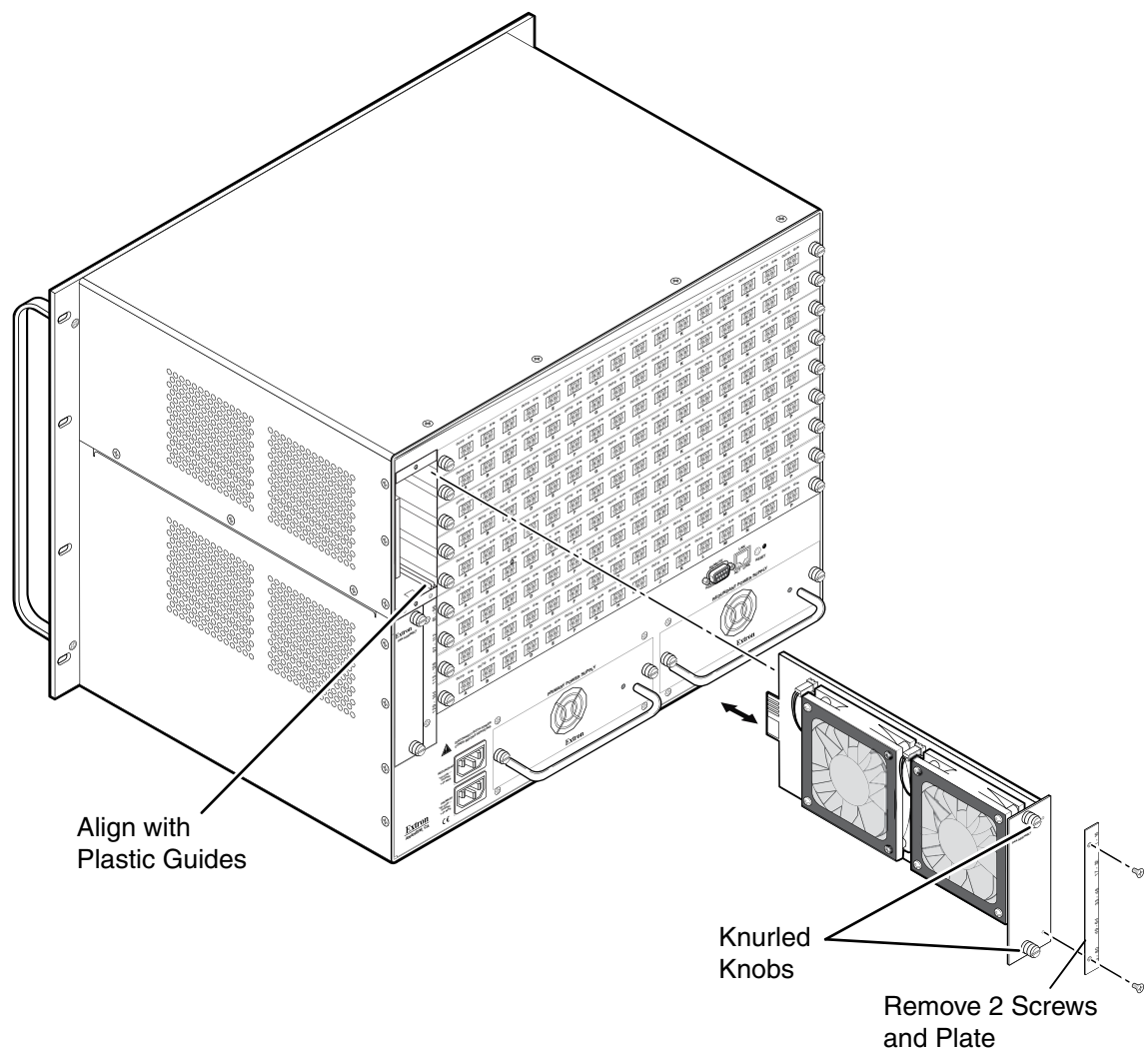

**Figure 49. Fan Replacement**

2. Rotate the top and bottom knurled knobs to completely loosen the captive thumbscrews.
3. Gently pull on the screws to loosen the fan from the backplane.
4. Slide the fan out of the chassis.

## Installing a Fan Module

**NOTE:** Captive thumbscrews must be tightened with a screwdriver after both initial installation and subsequent replacement of a fan module.

Install a fan module as follows:

1. Orient the fan to be installed so that the printing on the back of the panel is rightside up.
2. Align the flanges on the fan with the top and bottom fan guides (see **figure 49**, on the previous page).
3. Gently slide the fan into the enclosure until the fan meets resistance.
4. Gently seat the fan in the backplane.
5. Use a screwdriver to tighten the top and bottom captive thumbscrews to secure the fan in place.
6. Secure the row identification plate to the fan.

# Ethernet Connection

This section provides a high level discussion of the Ethernet connection to the switcher and a primer on the subject of subnetting. Topics that are covered, include:

- **Ethernet Link**
- **Subnetting – A Primer**

## Ethernet Link

The rear panel Ethernet connector on the FOX matrix switcher can be connected to an Ethernet LAN or WAN. This connection makes SIS control of the switcher possible using a computer connected to the same LAN.

### Ethernet Connection

The Ethernet cable can be terminated as a straight-through cable or a crossover cable and must be properly terminated for your application (see **figure 10** on page 14).

- **Crossover cable** — Direct connection between the computer and the FOX matrix switcher
- **Patch (straight-through) cable** — Connection of the FOX matrix switcher to an Ethernet LAN

### Default IP Address

To access the FOX matrix switcher via the LAN port, you need the IP address of the switcher. If the address has been changed to an address comprised of words and characters, you can determine the actual numeric IP address using the ping utility. If the address has not been changed, the factory-specified default is 192.168.254.254.

The Ping command can also be used to test the Ethernet link to the FOX matrix switcher.

## Pinging to Determine the Extron IP Address

The ping utility is available at the Command prompt. Ping tests the Ethernet interface between the computer and the FOX matrix switcher. Ping can also be used to determine the actual numeric IP address from an alias and to determine the web address.

Ping the switcher as follows:

1. On the Windows task bar, click on **Start > Run**.
2. At the **Open** prompt, type **command**.
3. Click the **OK** button.
4. At the **Command** prompt, type **ping {IP address}** and then press <Enter>. The computer returns a display similar to the one shown in figure 50.

The line **Pinging . . .** reports the actual numeric IP address, regardless of whether you entered the actual numeric IP address or an alias name.

```
C:\>ping 192.168.254.254

Pinging 192.168.254.254 with 32 bytes of data:

Reply from 192.168.254.254: bytes=32 time<10ms TTL=128
Reply from 192.168.254.254: bytes=32 time<10ms TTL=128
Reply from 192.168.254.254: bytes=32 time<10ms TTL=128
Reply from 192.168.254.254: bytes=32 time<10ms TTL=128

Ping statistics for 192.168.254.254:
    Packets: Sent = 4, Received = 4, Lost = 0 (0% loss),
    Approximate round trip times in milli-seconds:
        Minimum = 0ms, Maximum = 0ms, Average = 0ms
```

**Figure 50. Typical Ping Response**

## Pinging to Determine the Web IP Address

The ping utility has a modifier, **-a**, that directs the command to return the web address rather than the numeric IP address.

At the **Command** prompt, type **ping -a {IP address}** and then press <Enter>. The return display is similar to the ping response shown in **figure 51** on the next page, except that when you specify the **-a** modifier, the line **Pinging mail. . .** reports the web IP address rather than the numeric IP address, regardless of whether you entered the actual numeric IP address or an alias name.

## Configuring the Switcher for Network Use via the ARP Command

The ARP (address resolution protocol) command tells your computer to associate the MAC (media access control) address of the FOX matrix switcher with the assigned IP address. You must then use the ping utility to access the controller, at which point the IP address of the controller is reconfigured.

Use ARP to configure the IP address as follows:

1. Obtain a valid IP address for the FOX matrix switcher from your network administrator.
2. Obtain the MAC address (UID #) of the FOX matrix switcher from the label on its rear panel. The MAC address should have this format: 00-05-A6-xx-xx-xx.
3. If the FOX matrix switcher has never been configured and is still set for factory defaults, proceed to step 4. If not, perform a mode 4 system reset and then proceed to step 4. For detailed information on reset modes, see [Performing Soft System Resets \(Resets 3, 4, and 5\)](#) on page 19.

**NOTE:** The FOX matrix switcher must be configured with the factory default IP address (192.168.254.254) before the ARP command is executed, as described below.

4. At the PC, access the Command prompt (see [Pinging to Determine the Extron IP Address](#), on the previous page, steps 1 through 3), then enter the `arp -s` command. Type in the desired new IP address for the unit (obtained in step 1) and the MAC address of the unit (from the rear panel of the unit), for example, `arp -s 192.168.254.254 00-05-A6-03-69-B0` and then press <Enter>.

The computer returns the command prompt (C:\).

After you issue the `arp -s` command, the controller changes to the new address and starts responding to the ping requests to the new address, as described in the next step.

**NOTE:** You must ping the FOX matrix switcher for the IP address change to take place. The response should show the new IP address, as shown in figure 51.

5. Execute a ping command by entering ping followed by a space and the new IP address at the command prompt. For example:

```
ping 192.168.254.254
```

```
C:\>ping 192.168.254.254

Pinging 192.168.254.254 with 32 bytes of data:

Reply from 192.168.254.254: bytes=32 time<10ms TTL=128
Reply from 192.168.254.254: bytes=32 time<10ms TTL=128
Reply from 192.168.254.254: bytes=32 time<10ms TTL=128
Reply from 192.168.254.254: bytes=32 time<10ms TTL=128

Ping statistics for 192.168.254.254:
    Packets: Sent = 4, Received = 4, Lost = 0 (0% loss),
    Approximate round trip times in milli-seconds:
        Minimum = 0ms, Maximum = 0ms, Average = 0ms
```

**Figure 51. Ping with New Address**

**NOTE:** You can reconnect using either Telnet or a web browser to verify that the update was successful.

6. After verifying that the IP address change was successful, enter and issue the `arp -d` command at the Command prompt. For example:  
`arp -d 192.168.254.254` removes 192.168.254.254 from the ARP table  
*or*  
`arp -d*` removes all static IP addresses from the ARP table.

## Connecting as a Telnet Client

The Telnet utility is available from the Command prompt. Telnet allows you to input SIS commands to the FOX matrix switcher from the PC via the Ethernet link and the LAN.

Access the Command prompt and start Telnet as follows:

1. On the Windows task bar, click **Start > Run**.
2. At the **Open** prompt, type `command`.
3. Click the **OK** button.
4. At the **Command** prompt, type `Telnet` and then press <Enter>. The computer returns a display similar to the one shown in figure 52.

```
Microsoft (R) windows 2000 (TM) Version 5.0 (Build 2195)
Welcome to Microsoft Telnet Client
Telnet Client Build 5.00.99203.1

Escape Character is 'CTRL+]'

Microsoft Telnet>
```

**Figure 52.** Telnet Window

## Telnet Tips

It is not the intention of this guide to detail all of the operations and functionality of Telnet; however, some basic level of understanding is necessary for operating the FOX matrix switcher via Telnet.

### Open

Connect to the FOX matrix switcher using the Open command. Once you are connected to the switcher, you can enter the SIS commands the same as you would if you were using the RS-232 or RS-422 link.

Connect to the FOX matrix switcher as follows:

1. At the `Te1net` prompt, type `open {IP address}` and then press <Enter>.

**If the switcher is password protected**, Telnet displays the password prompt.

**NOTE:** The factory configured passwords for all accounts on this device have been set to the device serial number. Passwords are case sensitive.

**If the switcher is not password protected**, no further prompts are displayed until you break or disconnect the connection to the matrix switcher.

2. If necessary, at the password prompt, type the appropriate password and then press <Enter>.

Connection to the switcher via the Ethernet can be password protected. There are two levels of password protection: administrator and user. A person logged on as an administrator has full access to all matrix switcher switching capabilities and editing functions. Users can create ties, set mutes, and view all settings with the exception of passwords. By default, the FOX matrix switcher is shipped with both passwords set to `{carriage return}`.

Once you are logged in, the switcher returns either `Login Administrator` or `Login User`. No further prompts are displayed until you break or disconnect the connection to the FOX matrix switcher.

### Escape character and Esc key

When Telnet is first started, the utility advises that the Escape character is 'Ctrl+J'. Many SIS commands include the keyboard <Esc> key. Consequently, some confusion may exist between the Escape character and the Escape key.

The Telnet Escape character is a key combination, the <Ctrl> key and the <J> key pressed simultaneously, which returns you to the `Te1net` prompt while leaving the connection to the FOX matrix switcher intact.

The Escape key is the <Esc> key on the computer keyboard.

### Local echo

Once connected to the FOX matrix switcher, by default, Telnet does not display your keystrokes on the screen. SIS commands are typed in blindly and only the SIS responses are displayed on the screen. To command Telnet to show keystrokes, at the `Te1net` prompt, type `set local_echo` and then press <Enter> before you open the connection to the switcher.

With local echo turned on, keystrokes and the responses of the switcher are displayed on the same line. For example: `1*1!In1 Out1 A11`, where `1*1!` is the SIS command and `In1 Out1 A11` is the response.

With local echo turned on, all keystrokes are displayed, even those that should be masked, such as the password entry. For example, when entering a password with local echo turned on, you see a display such as `a*d*m*i*n*`, where `admin` is the keyed in password and `*****` is the masked response.

You can turn off local echo by typing `unset local_echo` and then pressing <Enter> at the Telnet prompt. If you are connected to the FOX matrix switcher and need to access the Telnet prompt to turn local echo off, type the Escape character (<Ctrl>+<]>).

### **Set carriage return-line feed**

Unless commanded otherwise, Telnet transmits a line feed character only (no carriage return) to the connected switcher when you press the <Enter> key. This is the correct setting for SIS communication with the switcher. The Telnet `set crlf` command forces Telnet to transmit carriage return and line feed characters when <Enter> is pressed, but if `crlf` is set, the SIS link with the switcher does not function properly.

### **Close**

To close the link to the switcher, access the `Telnet` prompt by typing the Escape character (<Ctrl>+<]>). At the Telnet prompt, type `close`, and then press <Enter>.

### **Help**

For Telnet command definitions, at the `Telnet` prompt, type `?` and then press <Enter>.

### **Quit**

Exit the Telnet utility by typing `quit` and then pressing <Enter> at the `Telnet` prompt. If you are connected to the FOX matrix switcher, access the `Telnet` prompt by typing the Escape character (<Ctrl>+<]>).

## **Subnetting — A Primer**

It is not the purpose of this guide to describe TCP/IP protocol in detail. However, some understanding of TCP/IP subnetting (a subnet is a subset of a network — a set of IP devices that have portions of their IP addresses in common) is necessary in order to understand the interaction of the FOX matrix switcher and the mail server gateway. To understand subnetting at the level required to install and operate the FOX matrix switcher, you must understand the concepts of a gateway, local and remote devices, IP addresses and octets, and subnet masks and octets.

### **Gateways**

The FOX matrix switcher can communicate with the e-mail server that the switcher uses for e-mail notification directly (if they are on the same subnet) or the communication can be routed via a gateway (a computer that provides a link between different subnets).

### **Local and Remote Devices**

The local and remote devices are defined from the point of view of the function being described. In this guide, subnetting is an issue when you are using the controlling PC to set TCP/IP and e-mail values in the matrix switcher (see [IP Settings / Options Dialog Box](#) on page 43 and [Email Settings Page](#) on page 66). When you are setting up the variables for e-mail notification, which may include subnetting, the matrix switcher is the local device and the e-mail server is the remote device.

## IP Addresses and Octets

Valid IP addresses consist of four 1-, 2-, or 3-digit numeric subfields, properly called “octets,” separated by dots (periods) (see figure 53). Each octet can be numbered from 000 through 255. Leading zeroes, up to three digits total per octet, are optional. Values of 256 and above are invalid.

Typical IP Address: 192,168,254,254  
Octets

**Figure 53. Typical IP Address**

## Subnet Masks and Octets

The subnet mask (see figure 54) is used to determine whether the local and remote devices are on the same subnet or different subnets. The subnet mask consists of four numeric octets separated by dots. Each octet can be numbered from 000 through 255. Leading zeroes, up to three digits total per octet, are optional. Each octet typically contains either 255 or 0. The octets determine whether or not the same octets of two IP addresses will be compared when determining if two devices are on the same subnet.

255 indicates that this octet will be compared between two IP addresses.      0 indicates that this octet will **not** be compared between two IP addresses.

Typical Subnet Mask: 255,255,0,0  
Octets

**Figure 54. Typical Subnet Mask**

## Determining Whether Devices Are on the Same Subnet

To determine the subnet, the IP address of the local device is compared to the IP address of the remote device (see figure 55). The octets of each address are compared or not compared, depending on the value in the related subnet mask octet.

- If a subnet mask octet contains the value 255, the related octets of the IP addresses of the local device and the remote device are unmasked.

**Unmasked octets are compared** (indicated by **?** in figure 55).

- If the subnet mask octet contains the value 0, the related octets of the IP addresses of the local device and remote device are masked.

**Masked octets are not compared** (indicated by **X** in figure 55).

If the unmasked octets of the two IP addresses **match** (indicated by **=** in figure 55, example 1), the two addresses **are on the same subnet**.

If the two unmasked fields **do not match** (indicated by **≠** in figure 55, example 2 and example 3), the addresses **are not on the same subnet**.

	Example 1	Example 2	Example 3
Local IP Address:	192.168.254.254	192.168.254.254	192.168.254.254
Subnet Mask:	255.255.0.0 (?.?.X.X)	255.255.0.0 (?.?.X.X)	255.255.0.0 (?.?.X.X)
Remote IP Address:	192.168.2.25	190.190.2.25	192.190.2.25
Match?:	=.?.X.X — Match (Same subnet)	≠.?.X.X — No match (Different subnet)	≠.?.X.X — No match (Different subnet)

**Figure 55. Comparing the IP Addresses of the Local and Remote Devices**

## Extron Warranty

Extron Electronics warrants this product against defects in materials and workmanship for a period of three years from the date of purchase. In the event of malfunction during the warranty period attributable directly to faulty workmanship and/or materials, Extron Electronics will, at its option, repair or replace said products or components, to whatever extent it shall deem necessary to restore said product to proper operating condition, provided that it is returned within the warranty period, with proof of purchase and description of malfunction to:

**USA, Canada, South America,  
and Central America:**

Extron Electronics  
1230 South Lewis Street  
Anaheim, CA 92805  
U.S.A.

**Asia:**

Extron Asia Pte Ltd  
135 Joo Seng Road, #04-01  
PM Industrial Bldg.  
Singapore 368363  
Singapore

**Japan:**

Extron Electronics, Japan  
Kyodo Building, 16 Ichibancho  
Chiyoda-ku, Tokyo 102-0082  
Japan

**Europe:**

Extron Europe  
Hanzeboulevard 10  
3825 PH Amersfoort  
The Netherlands

**China:**

Extron China  
686 Ronghua Road  
Songjiang District  
Shanghai 201611  
China

**Middle East:**

Extron Middle East  
Dubai Airport Free Zone  
F13, PO Box 293666  
United Arab Emirates, Dubai

**Africa:**

Extron South Africa  
South Tower  
160 Jan Smuts Avenue  
Rosebank 2196, South Africa

This Limited Warranty does not apply if the fault has been caused by misuse, improper handling care, electrical or mechanical abuse, abnormal operating conditions, or if modifications were made to the product that were not authorized by Extron.

**NOTE:** If a product is defective, please call Extron and ask for an Application Engineer to receive an RA (Return Authorization) number. This will begin the repair process.

**USA:** 714.491.1500 or 800.633.9876

**Asia:** 65.6383.4400

**Europe:** 31.33.453.4040 or 800.3987.6673

**Japan:** 81.3.3511.7655

**Africa:** 27.11.447.6162

**Middle East:** 971.4.299.1800

Units must be returned insured, with shipping charges prepaid. If not insured, you assume the risk of loss or damage during shipment. Returned units must include the serial number and a description of the problem, as well as the name of the person to contact in case there are any questions.

Extron Electronics makes no further warranties either expressed or implied with respect to the product and its quality, performance, merchantability, or fitness for any particular use. In no event will Extron Electronics be liable for direct, indirect, or consequential damages resulting from any defect in this product even if Extron Electronics has been advised of such damage.

Please note that laws vary from state to state and country to country, and that some provisions of this warranty may not apply to you.