

Setup Guide

Fiber Optic Matrix Switchers

IMPORTANT:
Refer to www.extron.com for the complete user guide, installation instructions, and specifications before connecting the product to the power source.

FOX Matrix 320x FOX Matrix 14400

Modular Fiber Optic Matrix Switchers





Extron

68-1539-51 Rev. B
10 19

Safety Instructions

Safety Instructions • English

⚠ WARNING: This symbol, , when used on the product, is intended to alert the user of the presence of uninsulated dangerous voltage within the product's enclosure that may present a risk of electric shock.

ATTENTION: This symbol, , when used on the product, is intended to alert the user of important operating and maintenance (servicing) instructions in the literature provided with the equipment.

For information on safety guidelines, regulatory compliances, EMI/EMF compatibility, accessibility, and related topics, see the Extron Safety and Regulatory Compliance Guide, part number 68-290-01, on the Extron website, www.extron.com.

Sicherheitsanweisungen • Deutsch

WARNUNG: Dieses Symbol , auf dem Produkt soll den Benutzer darauf aufmerksam machen, dass im Inneren des Gehäuses dieses Produktes gefährliche Spannungen herrschen, die nicht isoliert sind und die einen elektrischen Schlag verursachen können.

VORSICHT: Dieses Symbol , auf dem Produkt soll dem Benutzer in der im Lieferumfang enthaltenen Dokumentation besonders wichtige Hinweise zur Bedienung und Wartung (Instandhaltung) geben.

Weitere Informationen über die Sicherheitsrichtlinien, Produkthandhabung, EMI/EMF-Kompatibilität, Zugänglichkeit und verwandte Themen finden Sie in den Extron-Richtlinien für Sicherheit und Handhabung (Artikelnummer 68-290-01) auf der Extron-Website, www.extron.com.

Instrucciones de seguridad • Español

ADVERTENCIA: Este símbolo, , cuando se utiliza en el producto, avisa al usuario de la presencia de voltaje peligroso sin aislar dentro del producto, lo que puede representar un riesgo de descarga eléctrica.

ATENCIÓN: Este símbolo, , cuando se utiliza en el producto, avisa al usuario de la presencia de importantes instrucciones de uso y mantenimiento recogidas en la documentación proporcionada con el equipo.

Para obtener información sobre directrices de seguridad, cumplimiento de normativas, compatibilidad electromagnética, accesibilidad y temas relacionados, consulte la Guía de cumplimiento de normativas y seguridad de Extron, referencia 68-290-01, en el sitio Web de Extron, www.extron.com.

Instructions de sécurité • Français

AVERTISSEMENT: Ce pictogramme, , lorsqu'il est utilisé sur le produit, signale à l'utilisateur la présence à l'intérieur du boîtier du produit d'une tension électrique dangereuse susceptible de provoquer un choc électrique.

ATTENTION: Ce pictogramme, , lorsqu'il est utilisé sur le produit, signale à l'utilisateur des instructions d'utilisation ou de maintenance importantes qui se trouvent dans la documentation fournie avec le matériel.

Pour en savoir plus sur les règles de sécurité, la conformité à la réglementation, la compatibilité EMI/EMF, l'accessibilité, et autres sujets connexes, lisez les informations de sécurité et de conformité Extron, réf. 68-290-01, sur le site Extron, www.extron.com.

Istruzioni di sicurezza • Italiano

AVVERTENZA: Il simbolo, , se usato sul prodotto, serve ad avvertire l'utente della presenza di tensione non isolata pericolosa all'interno del contenitore del prodotto che può costituire un rischio di scosse elettriche.

ATTENZIONE: Il simbolo, , se usato sul prodotto, serve ad avvertire l'utente della presenza di importanti istruzioni di funzionamento e manutenzione nella documentazione fornita con l'apparecchio.

Per informazioni su parametri di sicurezza, conformità alle normative, compatibilità EMI/EMF, accessibilità e argomenti simili, fare riferimento alla Guida alla conformità normativa e di sicurezza di Extron, cod. articolo 68-290-01, sul sito web di Extron, www.extron.com.

Instrukcje bezpieczeństwa • Polska

OSTRZEŻENIE: Ten symbol, , gdy używany na produkt, ma na celu poinformować użytkownika o obecności izolowanego i niebezpiecznego napięcia wewnątrz obudowy produktu, który może stanowić zagrożenie porażenia prądem elektrycznym.

UWAGI: Ten symbol, , gdy używany na produkt, jest przeznaczony do ostrzegania użytkownika ważne operacyjne oraz instrukcje konserwacji (obsługi) w literaturze, wyposażone w sprzęt.

Informacji na temat wytycznych w sprawie bezpieczeństwa, regulacji wzajemnej zgodności, zgodność EMI/EMF, dostępności i Tematy pokrewne, zobacz Extron bezpieczeństwa i regulacyjnego zgodności przewodnik, część numer 68-290-01, na stronie internetowej Extron, www.extron.com.

Инструкция по технике безопасности • Русский

ПРЕДУПРЕЖДЕНИЕ: Данный символ, , если указан на продукте, предупреждает пользователя о наличии неизолированного опасного напряжения внутри корпуса продукта, которое может привести к поражению электрическим током.

ВНИМАНИЕ: Данный символ, , если указан на продукте, предупреждает пользователя о наличии важных инструкций по эксплуатации и обслуживанию в руководстве, прилагаемом к данному оборудованию.

Для получения информации о правилах техники безопасности, соблюдении нормативных требований, электромагнитной совместимости (ЭМП/ЭДС), возможности доступа и других вопросах см. руководство по безопасности и соблюдению нормативных требований Extron на сайте Extron: www.extron.com, номер по каталогу - 68-290-01.

安全说明 • 简体中文

警告:  产品上的这个标志意在警告用户该产品机壳内有暴露的危险电压,有触电危险。

注意:  产品上的这个标志意在提示用户设备随附的用户手册中有重要的操作和维护(维修)说明。

关于我们产品的安全指南、遵循的规范、EMI/EMF 的兼容性、无障碍使用的特性等相关内容, 敬请访问 Extron 网站 www.extron.com, 参见 Extron 安全规范指南, 产品编号 68-290-01。

安全記事・繁體中文

警告: ⚠️若產品上使用此符號，是為了提醒使用者，產品機殼內存在著可能會導致觸電之風險的未絕緣危險電壓。

注意: ⚠️若產品上使用此符號，是為了提醒使用者，設備隨附的用戶手冊中有重要的操作和維護（維修）明。

有關安全性指導方針、法規遵守、EMI/EMF 相容性、存取範圍和相關主題的詳細資訊，請瀏覽 Extron 網站：www.extron.com，然後參閱《Extron 安全性與法規遵守手冊》，準則編號 68-290-01。

安全上のご注意・日本語

警告: この記号 ⚠️ が製品上に表示されている場合は、筐体内に絶縁されていない高電圧が流れ、感電の危険があることを示しています。

注意: この記号 ⚠️ が製品上に表示されている場合は、本機の取扱説明書に記載されている重要な操作と保守(整備)の指示についてユーザーの注意を喚起するものです。

安全上のご注意、法規遵守、EMI/EMF適合性、その他の関連項目については、エクストロンのウェブサイトwww.extron.comより「Extron Safety and Regulatory Compliance Guide」(P/N 68-290-01)をご覧ください。

안전 지침・한국어

경고: 이 기호 ⚠️가 제품에 사용될 경우, 제품의 인클로저 내에 있는 접지되지 않은 위험한 전류로 인해 사용자가 감전될 위험이 있음을 경고합니다.

주의: 이 기호 ⚠️가 제품에 사용될 경우, 장비와 함께 제공된 책자에 나와 있는 주요 운영 및 유지보수(정비) 지침을 경고합니다.

안전 가이드라인, 규제 준수, EMI/EMF 호환성, 접근성, 그리고 관련 항목에 대한 자세한 내용은 Extron 웹 사이트(www.extron.com)의 Extron 안전 및 규제 준수 안내서, 68-290-01 조항을 참조하십시오.

NOTE: For more information on safety guidelines, regulatory compliances, EMI/EMF compatibility, accessibility, and related topics, see the “[Extron Safety and Regulatory Compliance Guide](#)” on the Extron website.

Copyright

© 2014-2019 Extron Electronics. All rights reserved. www.extron.com

Trademarks

All trademarks mentioned in this guide are the properties of their respective owners. The following registered trademarks, registered service marks, and trademarks are the property of RGB Systems, Inc. or Extron Electronics (see the current list of trademarks on the [Terms of Use](#) page at www.extron.com):

Registered Trademarks®

Extron, AVTrac, Cable Cubby, ControlScript, CrossPoint, DTP, eBUS, EDID Manager, EDID Minder, Flat Field, FlexOS, Glitch Free, Global Configurator, Global Scriptor, GlobalViewer, Hideaway, HyperLane, HyperLane, IP Intercom, IP Link, Key Minder, LinkLicense, LockIt, MediaLink, MediaPort, NetPA, PlenumVault, PoleVault, PowerCage, PURE3, Quantum, Show Me, SoundField, SpeedMount, SpeedSwitch, StudioStation, System *INTEGRATOR*, TeamWork, TouchLink, V-Lock, VersaTools, VN-Matrix, VoiceLift, WallVault, WindoWall, XPA, XTP, XTP Systems, and ZipClip

Registered Service Mark^(SM): S3 Service Support Solutions

Trademarks^(TM)

AAP, AFL (Accu-RATE Frame Lock), ADSP (Advanced Digital Sync Processing), Auto-Image, AVEdge, CableCover, CDRS (Class D Ripple Suppression), DDSP (Digital Display Sync Processing), DMI (Dynamic Motion Interpolation), Driver Configurator, DSP Configurator, DSVP (Digital Sync Validation Processing), eLink, EQIP, EverLast, FastBite, Flex55, FOX, FOXBOX, IP Intercom HelpDesk, MAAP, MicroDigital, Opti-Torque, ProDSP, QS-FPC (QuickSwitch Front Panel Controller), Room Agent, Scope-Trigger, ShareLink, SIS, Simple Instruction Set, Skew-Free, SpeedNav, Triple-Action Switching, True4K, VectorTM 4K, WebShare, XTRA, and ZipCaddy

FCC Class A Notice

This equipment has been tested and found to comply with the limits for a Class A digital device, pursuant to part 15 of the FCC rules. The Class A limits provide reasonable protection against harmful interference when the equipment is operated in a commercial environment. This equipment generates, uses, and can radiate radio frequency energy and, if not installed and used in accordance with the instruction manual, may cause harmful interference to radio communications. Operation of this equipment in a residential area is likely to cause interference. This interference must be corrected at the expense of the user.

NOTE: The Twisted Pair Extension technology works with unshielded twisted pair (UTP) or shielded twisted pair (STP) cables; but to ensure FCC Class A and CE compliance, STP cables and STP Connectors are required.

For more information on safety guidelines, regulatory compliances, EMI/EMF compatibility, accessibility, and related topics, see the "[Extron Safety and Regulatory Compliance Guide](#)" on the Extron website.

Conventions Used in this Guide

Notifications



WARNING: Potential risk of severe injury or death.

AVERTISSEMENT: Risque potentiel de blessure grave ou de mort.

ATTENTION:

- Risk of property damage.
- Risque de dommages matériels.

NOTE: A note draws attention to important information.

Software Commands

Commands are written in the fonts shown here:

```
^ARMerge Scene, ,Op1 scene 1,1 ^B 51 ^W^C  
[01] R 0004 00300 00400 00800 00600 [02] 35 [17] [03]
```

```
Esc [X1] * [X17] * [X20] * [X23] * [X21] CE ←
```

NOTE: For commands and examples of computer or device responses mentioned in this guide, the character “0” is used for the number zero and “O” is the capital letter “o.”

Computer responses and directory paths that do not have variables are written in the font shown here:

```
Reply from 208.132.180.48: bytes=32 times=2ms TTL=32  
C:\Program Files\Extron
```

Variables are written in slanted form as shown here:

```
ping xxx.xxx.xxx.xxx -t  
SOH R Data STX Command ETB ETX
```

Selectable items, such as menu names, menu options, buttons, tabs, and field names are written in the font shown here:

```
From the File menu, select New.  
Click the OK button.
```

Specifications Availability

Product specifications are available on the Extron website, www.extron.com.



Contents

Introduction	1
About this Guide	1
About the FOX Matrix Switchers... ..	2
Configurability and Transmission Modes.....	3

Installation	5
Rear Panel.....	5
A Note on I/O Boards	5
Making Connections	8
Front Panel	10

Remote Control	13
Selected SIS Commands	13
Command and Response Table for SIS Commands.....	14
Matrix Switchers Control Program	16
Installing the Program	16
LAN Port Connection	17
Starting the Program	17
Built-in HTML Pages	19
Configuring for Network Communication.....	19
Loading the Start-up Page.....	20

Maintenance and Modifications	23
Removing and Installing an I/O Board or Blank Panel.....	23
Removing and Installing a Power Supply Module.....	25
Removing and Installing a Fan	26

Introduction

WARNING: The fiber optic I/O boards of the FOX matrix switchers output continuous invisible light, which may be harmful to the eyes; use with caution.

Do not look into the fiber optic cable connectors or into the fiber optic cables themselves.

Plug the attached dust caps into the optical transceivers when the fiber cable is unplugged.

AVERTISSEMENT : L'appareil émet une lumière invisible en continu, à utiliser avec précaution.

Ne regardez pas dans les connecteurs de câble fibre optique sur le panneau arrière ou dans les câbles fibre optique eux-mêmes.

Branchez les protections contre la poussière dans l'ensemble émetteur/récepteur lorsque le câble fibre optique est débranché.

This section provides an overview of the Extron FOX Matrix 320x and FOX Matrix 14400 and describes their features. Topics that are covered include:

- [About this Guide](#)
- [About the FOX Matrix Switchers](#)

About this Guide

NOTE: For more information on any subject in this guide, see the *FOX Matrix 320x and FOX Matrix 14400 Series User Guide*, available at www.extron.com.

This setup guide helps you to easily and quickly set up and configure your FOX Matrix 320x and FOX Matrix 14400 switcher. Step by step instructions show you how to:

- [Install the input and output boards](#)
- [Connect the hardware](#)
- [Use selected Simple Instruction Set \(SIS\) commands to perform basic operations](#)
- [Load and start the Matrix Switchers Control Program](#)
- [Connect to the built-in HTML pages](#), which you can use to operate the switcher

About the FOX Matrix Switchers

The FOX matrix switchers (see figure 1 for a FOX Matrix 14400 example) are configurable matrix switchers that distributes optical signals. Fiber optic I/O boards route signals that are compatible with all Extron FOX 500, FOXBOX, FOX, FOX 2G, and FOX HD-SDI fiber optic product lines. 3G/HD-SDI/SDI/ I/O boards route 3G, high definition serial digital interface (HD-SDI), and serial digital interface (SDI) signals. The matrix switcher routes any input signal to any combination of outputs. An optical input can be tied to optical outputs, 3G/HD-SDI SDI outputs, or both and an 3G/HD-SDI SDI input can be tied to 3G/HD-SDI/SDI outputs, optical outputs, or both. The matrix switcher can route multiple input/output configurations simultaneously.

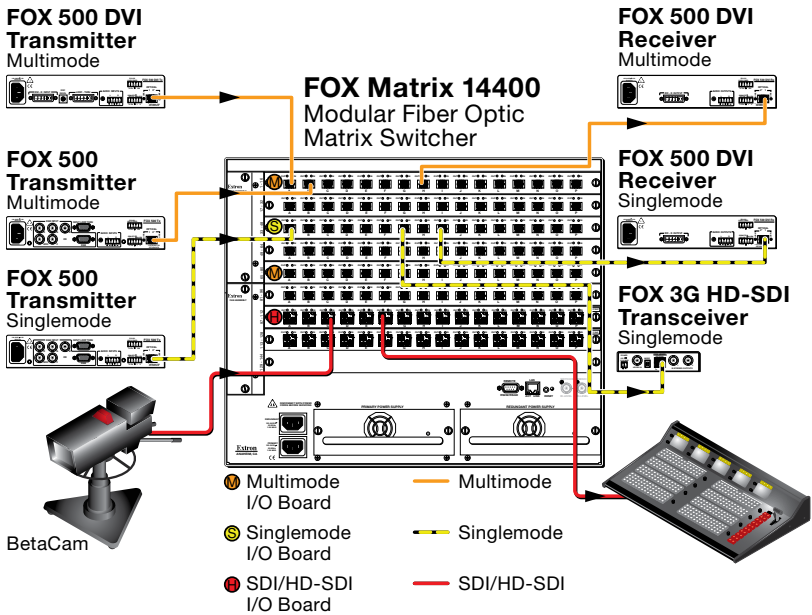

Figure 1. Typical FOX Matrix 14400 application

NOTE: In figure 1, the FOX 3G HD-SDI is set to bidirectional transceiver mode.

The Extron proprietary fiber optic signal, generated by Extron fiber optic transmitters, can include video, stereo audio, and transmitter-to-receiver RS-232 serial communications. The video component of the signal can be RGB video, Digital Visual Interface (DVI) video, HDMI video, 3G/HD-SDI/SDI video, or low resolution video, depending on the transmitter and receiver.

The matrix switcher can be remotely controlled via its Ethernet LAN port or either of two serial ports, one on the rear panel and one on the front panel, using either the Windows-based Extron Matrix Switchers Control Program or SIS.

NOTES:

- Compatible optical signals are digital signals from 270 Mbps through 4.25 Gbps that are sent and received via fiber optic small form factor pluggable (SFP) modules.
- The FOX transmitter-to-receiver communications, including the serial link, occupy one matrix switcher input and output. This matrix switcher can also support the FOX return (receiver-to-transmitter) serial communications, but returning this signal stream to the transmitter occupies a separate matrix switcher input and output.

The switcher has two (FOX Matrix 14400) or four (FOX Matrix 320x) internal, hot-swappable 100 VAC to 240 VAC, 50-60 Hz, 400-watt power supplies that provide worldwide power compatibility and reliability.

Configurability and Transmission Modes

The FOX matrix switchers are assembled from individual input/output (I/O) boards. The switcher can include up to 9 (FOX Matrix 14400) or 20 (FOX Matrix 320x) I/O boards, each of which supports 16 inputs by 16 outputs. The four types of I/O boards are:

- **Singlemode fiber optic 16x16 I/O board**
- **Multimode fiber optic 16x16 I/O board**
- **Singlemode pathological fiber optic 16x16 I/O board.** This board addresses the compatibility issues of passing pathological signals generated from 3G HD-SDI, HD-SDI, and SDI signals over fiber optic systems
- **3G HD-SDI, HD-SDI, and SDI 16x16 I/O board**

NOTE: As listed above, three versions of the fiber optic I/O boards are documented in this manual. They are categorized by the type of fiber optic cable, multimode or singlemode, which defines the effective range of transmission:

- **Singlemode** — Very long distance, up to 30 km (18.75 miles)
- **Multimode** — Long distance, up to 300 m (984 feet)

By adding or removing I/O boards, you can expand and contract the FOX Matrix Switchers from an 16-input by 16-output matrix to up to either:

- **FOX Matrix 14400** — A 144-input by 144-output matrix
- **FOX Matrix 320x** — A 320-input by 320-output matrix

NOTE: On a fiber optic I/O board as delivered from Extron, all transceiver modules are configured the same: either all multimode or all singlemode. You can mix multimode and singlemode fiber optic I/O boards in a FOX matrix switcher, but you must ensure that you connect the proper transmission mode fiber cables to the board.

Installation

This section describes installation of the FOX matrix switchers, including connections and features. Topics that are covered include:

- **Rear Panel**
- **Front Panel**

Rear Panel

A Note on I/O Boards

As shown in figure 2, each I/O board is identified by the input and output numbers supported by the board position.

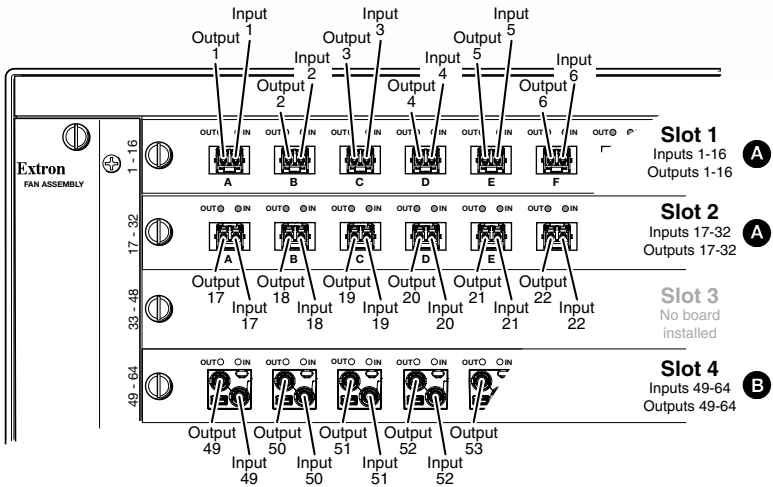

Figure 2. Arrangement of Inputs and Outputs on the I/O Boards

The board position designators correspond to the input and output numbers served by that position (1 - 16, 17 - 32, and so on).

The location designators, A through P, correspond to the transceiver modules, numbered from left to right, each of which includes an input and an output.

In figure 2, the input and output numbers supported by the I/O board in location 17 - 32 are as follows: A = 17, B = 18, C = 19, D = 20, and so on.

ATTENTION:

- Turn off power to the input and output devices, and disconnect their power cords before making connections.
- Débranchez le produit et les autres appareils.

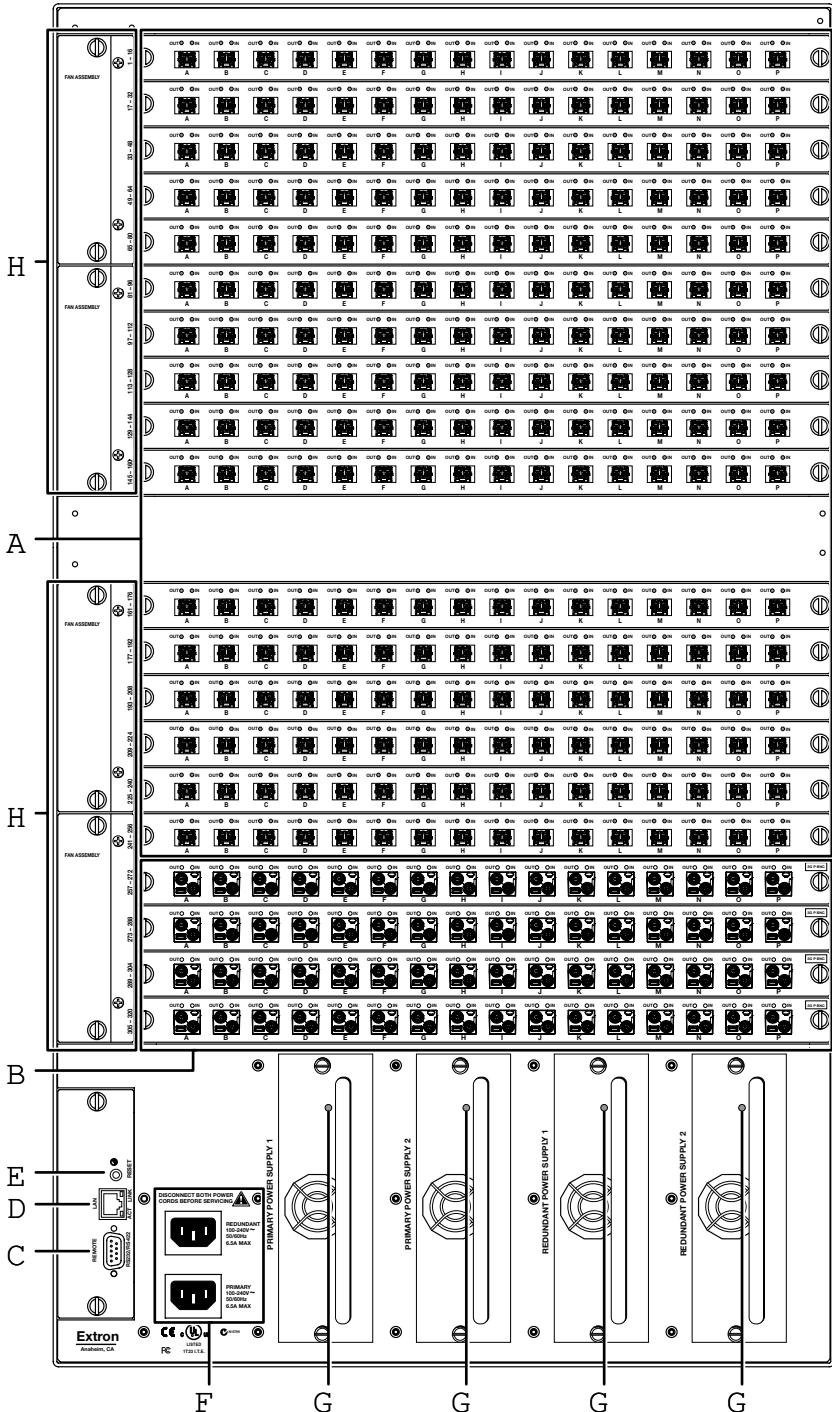

Figure 3. FOX Matrix 320x Switcher Rear Panel

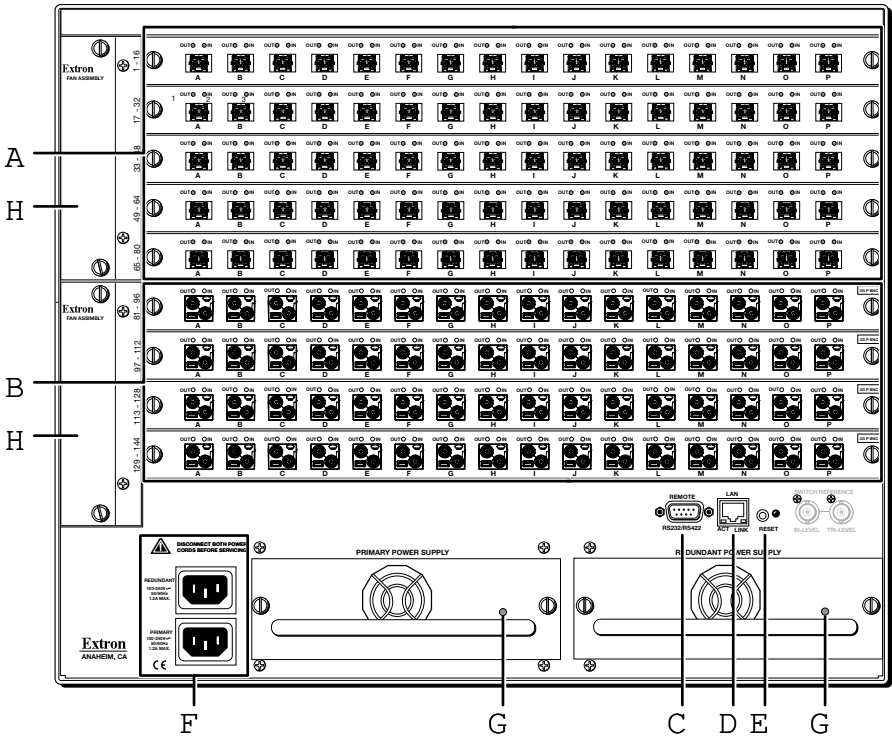

Figure 4. FOX Matrix 14400 Switcher Rear Panel

- A** Fiber optic boards with connectors and LEDs (see [page 8](#)).
- B** 3G HD-SDI, HDI-SDI, and SDI boards with DIN connectors (see [page 9](#)).
- C** Remote port (see [page 9](#)).
- D** Ethernet connection (LAN connector) (see [page 9](#)).
- E** Reset button and LED (see [page 9](#)).
- F** Primary and redundant power connectors (see [page 10](#)).
- G** Primary and redundant power supply LEDs (see [page 10](#)).
- H** Replaceable fans (see [Removing and Installing a Fan](#) on page 26 to replace the fan).

Making Connections

- A** **Fiber optic boards with connectors and LEDs** — (see [figure 3](#) on page 6 and [figure 4](#) on page 7).

WARNING: This unit outputs continuous invisible light, which may be harmful to the eyes; use with caution. For additional safety, plug the attached dust caps into the optical transceivers when the fiber cable is unplugged.

AVERTISSEMENT : L'appareil émet une lumière invisible en continu, à utiliser avec précaution. Branchez les protections contre la poussière dans l'ensemble émetteur/récepteur lorsque le câble fibre optique est débranché.

NOTES:

- Ensure that you use the proper fiber cable for your I/O board. Typically, singlemode fiber has a yellow jacket and multimode cable has an orange or cyan jacket.
- The FOX matrix switcher uses one connector on the block as an input and the second connector on the same block as a separate output.

- 1** **Input connector** — Connect a fiber optic cable between each Input LC connector and a FOX 500 Tx or any other compatible Extron FOX device.

NOTE: Or, for the serial return (receiver-to-transmitter) function, connect the far end to the Optical 2 connector on a FOX Rx receiver.

Input LED — See [Fiber optic I/O board LED indications](#) on page 10.

- 2** **Output connector** — Connect a fiber optic cable between each output LC connector and a FOX 500 Rx or any other compatible Extron FOX device.

NOTE: Or, for the serial return (receiver-to-transmitter) function, connect the far end to the Optical 2 connector on a FOX Tx transmitter.

Output LED — See [Fiber optic I/O board LED indications](#) on page 10.

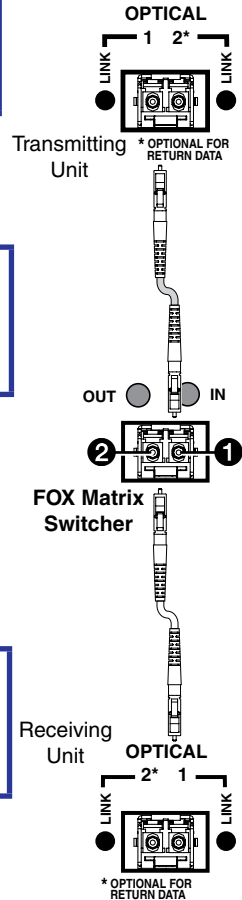

- B 3G HD-SDI, HDI-SDI, and SDI boards with DIN connectors** — Connect inputs and output using the included DIN-to-female-BNC pigtail connectors, as follows :

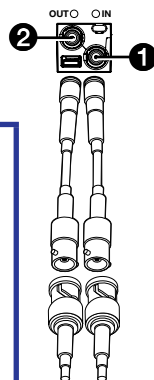

NOTES:

- The pigtails are not installed on the board during shipment.
- **To install the pigtails**, press them onto the DIN connectors until they snap into place.
- **To remove the pigtails**, pull back on the knurled collar and pull the pigtail straight back from the DIN connector.

- 1 Multi-rate SDI Input connectors** — Connect HD-SDI, SDI, or 3G-SDI video inputs to these BNC connectors.
- 2 Multi-rate SDI Output connectors** — Connect digital displays to these BNC connectors.
- C Remote RS-232/RS-422 port** — If desired, connect a control system or computer to the rear panel Remote RS-232/RS-422 port.

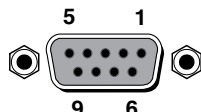

Pin	RS-232	Function	RS-422	Function
1	—	Not used	—	Not used
2	Tx	Transmit	Tx-	Transmit (-)
3	Rx	Receive	Rx-	Receive (-)
4	—	Not used	—	Not used
5	Gnd	Ground	Gnd	Ground
6	—	Not used	—	Not used
7	—	Not used	Rx+	Receive (+)
8	—	Not used	Tx+	Transmit (+)
9	—	Not used	—	Not used

Figure 5. Audio Output Connector Wiring

- D LAN port** — If desired, connect a network WAN or LAN hub, a control system, or a computer to the Ethernet RJ-45 port.

Network connection — Wire as a patch (straight) cable.

Computer or control system connection — Wire the interface cable as a crossover cable.

NOTE: The factory default IP address is 192.168.254.254.

- E Reset button** — Initiates four levels of reset of the matrix switcher. For different reset levels, press and hold the recessed button while the switcher is running or while you power up the switcher (see the *FOX 320x and 14400 Series User Guide*, available at www.extron.com).

NOTE: The factory configured passwords for all accounts on this device have been set to the device serial number. In the event of a complete system reset, the passwords convert to the default, which is no password.

- F Power connectors** — Plug the switcher into two grounded AC sources (see [figure 3](#) on page 6 and [figure 4](#) on page 7).

NOTE: For reliability, connect the Redundant power cord to either an uninterruptible power source or to a power source that is completely independent from the primary power source.

- G Primary and Redundant power supply LEDs** —
 - Green** — Indicates that the associated power supply is operating within normal tolerances.
 - Red** — Indicates that the associated power supply is operating outside the normal tolerances or has failed (see [Removing and Installing a Power Supply Module](#) on page 25).

Fiber optic I/O board LED indications

On the fiber optic I/O boards, the input and output LEDs on the transceivers provide useful indications of the status of the lasers and the reclocking function (see the table below).

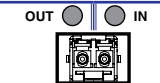
Definition			Definition
	Output LED indication	Input LED indication	
Reclocked at 4.25 Gbps	On	On	Reclocked at 4.25 Gbps
Not reclocked, laser off, or no signal	Off	Off	Not reclocked or no signal
Non-4G signal present or not reclocked	Fast blink	Fast blink	Non-4G signal present or not reclocked

Front Panel

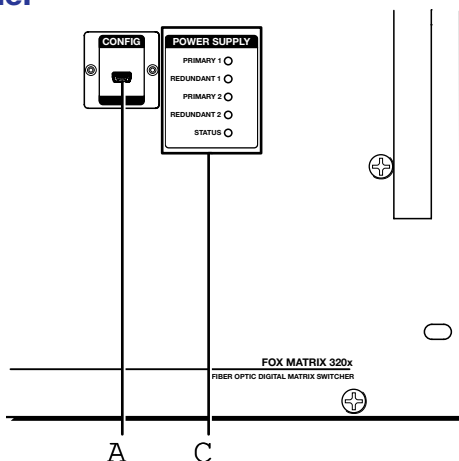

Figure 6. Front Panel Configuration Port, FOX Matrix 320x

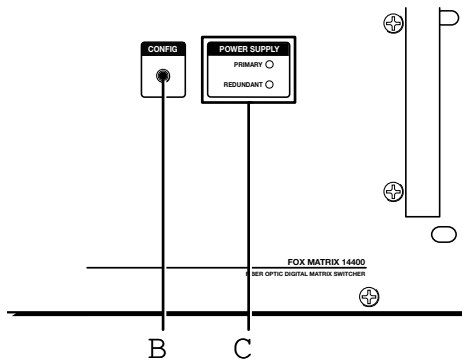

Figure 7. Front Panel Configuration Port, FOX Matrix 14400

- A Configuration port (FOX Matrix 320x)** — If desired, connect control system or computer to the front panel Configuration (USB) port. Use a standard mini USB B cable.
- B Configuration port (FOX Matrix 14400)** — If desired, connect a control system or computer to the front panel Configuration (RS-232) port. Use an optional 9-pin D to 2.5 mm mini jack TRS RS-232 cable.
- C Indicator LEDs** —
 - Primary and Redundant Power Supply LEDs** —
 - **Green** — Indicates that the associated power supply is operating within normal tolerances.
 - **Amber (FOX Matrix 320x only)** — Indicates that AC power is disconnected or the power supply has been removed.
 - **Red** — Indicates that the associated power supply is operating outside the normal tolerances or has failed see [Removing and Installing a Power Supply Module](#) on page 25) to replace the power supply.
 - Status LED (FOX Matrix 320x only)** —
 - **Green** — Indicates that the controller board is operating normally and that the temperature and backplane voltages are all within normal tolerances.
 - **Red** — Indicates that either the controller board has failed or that temperature or backplane voltages are outside of acceptable levels.

Remote Control

This section describes using the remote control features of the FOX matrix switchers to control the devices. Topics that are covered include:

- [Selected SIS Commands](#)
- [Command and Response Table for SIS Commands](#)
- [Matrix Switchers Control Program](#)
- [Built-in HTML Pages](#)

Selected SIS Commands

You can use Simple Instruction Set (SIS) commands for operation and configuration of the switchers. You can run these commands from a PC connected to the rear panel Remote RS-232/RS-422 port ([item ③](#) on page 9), LAN port ([item ④](#) on page 9), or front panel configuration port ([item ①](#) [FOX Matrix 320x] or [item ②](#) [FOX Matrix 14400] on page 11) on the switcher.

NOTE: The table that begins on the next page is a partial list of SIS commands. For a complete listing, see the *FOX Matrix 320x and FOX Matrix 14400 Series User Guide*.

Command and Response Table for SIS Commands

Command	ASCII Command (Host to Unit)	Response (Unit to Host)	Additional Description
Create ties			
NOTES:			
<ul style="list-style-type: none"> Commands can be entered back-to-back in a string, with no spaces. For example: 1*1102*02&003*003%4*24!. The matrix switchers support 1-, 2-, and 3-digit numeric entries (1*11, 02*02&, or 003*003%). The ! tie command, the & tie command, and the % tie command can be used interchangeably, as can the ! read tie command, the & tie command, and the % read tie command. 			
Tie input X1 to output X2	X1*<u>X2</u>!	Out <u>X2</u> *In <u>X1</u> •A11↓	Tie input X1 to output X2 .
<i>Example (see Note, above):</i>	1*3!	Out03•In01•A11↓	Tie input 1 to output 3.
Tie input X1 to output X2	X1*<u>X2</u>&	Out <u>X2</u> *In <u>X1</u> •RGB↓	Tie input X1 to output X2 .
<i>Example (see Note, above):</i>	10*4&	Out04•In10•RGB↓	Tie input 10 to output 4.
Tie input X1 to output X2	X1*<u>X2</u>%	Out <u>X2</u> *In <u>X1</u> •Vid↓	Tie input X1 to output X2 .
<i>Example (see Note, above):</i>	7*5%	Out05•In07•Vid↓	Tie input 7 to output 5.
Read output tie	X2&	X1 ↓	Input X1 is tied to output X2 .
Read output tie	X2%	X1 ↓	Input X1 is tied to output X2 .
Read output tie	X2!	X1 ↓	Input X1 is tied to output X2 .
Channel mutes			
Channel mute	X2*1B	Vmt <u>X2</u> *1↓	Mute output X2 (no signal is output, but the light output remains active).
Channel unmute	X2*0B	Vmt <u>X2</u> *0↓	Unmute output X2 (signal is output).
Read channel mute	X2B	X5 ↓	1 = mute on, 0 = mute off.
Global channel mute	1*B	Vmt1↓	Mute all light outputs.
Global channel unmute	0*B	Vmt0↓	Unmute all light outputs.
KEY:			
• = Space			
X1 = Input number			
X2 = Output number			
X5 = Mute			
00 – maximum number of inputs for your configuration (00 = untied)			
01 – maximum number of outputs for your configuration			
1 = mute on, 0 = mute off			

Command	ASCII Command (Host to Unit)	Response (Unit to Host)	Additional Description
Save and recall presets			
NOTE: If you try to recall a preset that is not saved, the matrix switcher responds with the error code E11.			
Save current configuration as a global preset <i>Example:</i>	[X4], 9,	Spr[X4]↵	Command character is a comma. Save current ties as preset 9.
Recall a global preset <i>Example:</i>	[X4]. 5.	Rpr[X4]↵ Rpr05↵	Command character is a period. Recall preset 5, which becomes the current configuration.
IP setup			
Set IP address	[Esc][X6]CI↵	I p i[X6]↵	
Read IP address	[Esc]CI↵	[X6]↵	
Set DHCP on or off	[Esc][X7]DH↵	I d h[X7]↵	
Read DHCP on/off status	[Esc]DH↵	[X7]↵	
KEY: [X4] = Global preset number 01 – 64 [X6] = IP address nnn.nnnn.nnnn.nnnn [X7] = DHCP 0 = off, 1 = on			

Matrix Switchers Control Program

Another way to operate the switcher is via the Matrix Switchers Control Program, which runs on computers that use the Windows® operating system. This program is available on the Extron website. You can run this program from a PC connected to the rear panel Remote RS-232/RS-422 port (item C on page 9), LAN port (item D on page 9), or front panel configuration port (item A [FOX Matrix 320x] or item E [FOX Matrix 14400] on page 11) on the switcher.

NOTE: For details on operating the program, see the “Matrix Software” section in the *FOX Matrix 320x and FOX Matrix 14400 User Guide*.

Installing the Program

The Matrix Switchers Control Program is available on the Extron website. Download and install all programs as follows:

1. Visit www.extron.com and mouse over the **Download** tab (see figure 8, 1).



Figure 8. Download Drop-down List

2. Click the **Software** link (2).
3. Select the desired software to download and click **Download** (3).

TIP: Jump to the nearest page of downloads by clicking the desired filtering letter.

Matrix Switchers	79-520-01	8.3	Sep. 16, 2013	15.0	3	Download
Control software for most Extron matrix switchers, including MAV Series (except MAV 62), MAV Plus, Matrix 50, CrossPoint, CrossPoint						

The Download Center dialog box appears (see figure 9, on the next page).

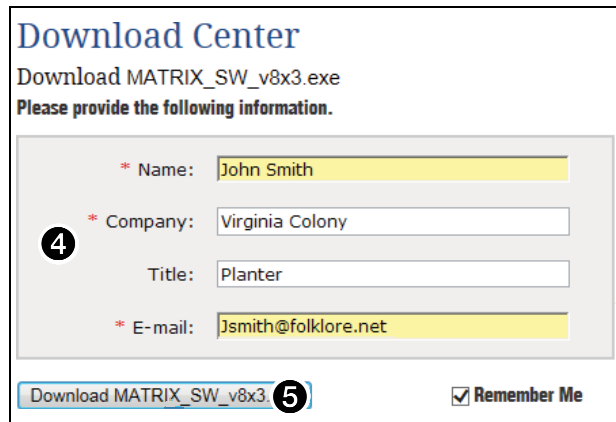
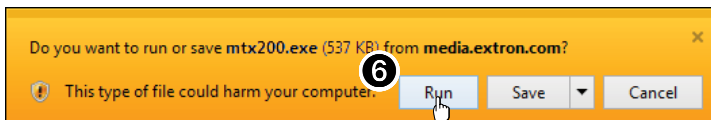

Figure 9. Download Center Dialog Box

4. Enter the requested personal information;

TIP: Click **Remember Me** (see figure 9, 4) to eliminate step 4 in future downloads.

5. Click **Download** (5) to copy the software or firmware to your computer. The download warns you about downloads and asks you to confirm it.



NOTE: The figure above may appear different or may not appear at all, depending on your web browser choice and its security settings.

6. Click **Run** to confirm that you want to run the installation.
7. Follow the on-screen instructions. The installation program creates the necessary directories and folders and installs the programs.

LAN Port Connection

The first time you connect your PC to the switcher via the LAN port, you may need to change the default settings (IP address, subnet mask, and [optional] administrator name and password) on the controller (see "Configuring for Network Communication" in the *FOX Matrix 320x and FOX Matrix 14400 User Guide*).

Starting the Program

1. Click **Start > Programs > Extron Electronics > Matrix Switchers > MATRIX Switcher + Control Pgm.**

The Comm Port Selection window appears.

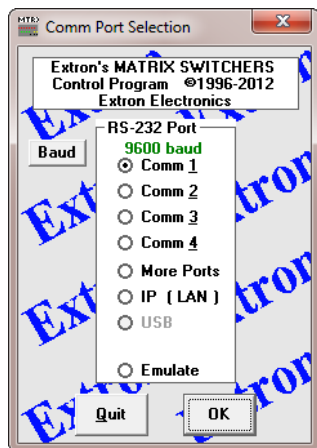

2. Choose the comm (serial) port that is connected to the switcher or IP [LAN].

NOTE: For a comm port, check the baud rate displayed in the Comm Port Selection window. If you need to change the baud rate, click the **Baud** button and double-click the desired baud rate.

9600 baud
19200 baud
38400 baud
115200 baud

3. Click **OK**.

If you selected a serial port in step 2, the Matrix Switchers Control Program is ready for operation.

4. **If you selected IP [LAN] in step 2**, the IP Connection window appears.

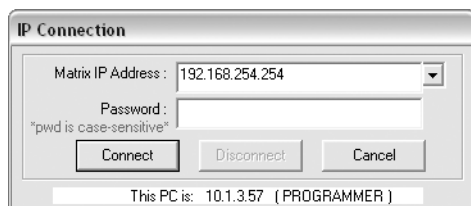

- a. Examine the Matrix IP Address field, which displays the last Matrix IP address entered.

If necessary, enter the correct IP address in the field.

NOTE: 192.168.254.254 is the factory-specified default IP address.

- b. If the switcher is password-protected, enter the appropriate administrator or user password in the **Password** field.
- c. Click **Connect**. The Matrix Switchers Control Program is ready for operation.

Built-in HTML Pages

Another way to configure and operate the switcher is via its factory-installed HTML pages, which are always available and cannot be erased or overwritten. The HTML pages that are pre-loaded on the switcher are accessible through its LAN port (**item ④** on page 9), connected via a LAN or WAN, using a web browser such as Microsoft® Internet Explorer®.

Configuring for Network Communication

The first time you connect a PC to a switcher via its LAN port, you may need to temporarily change the IP settings of the PC in order to communicate with the controller. Then you must change the default settings of the controller (IP address, subnet mask, and [optional] administrator name and password) in order to use the unit on an intranet (LAN) or on the Internet. After you have set up the FOX matrix switcher for network communication, you can reset the PC to its original network configuration.

NOTE: The computer and the switcher must both be connected to the same subnet on a LAN (using a straight-through cable). Alternatively, you can use a crossover Ethernet cable to connect the controller directly to the computer.

Use the ARP command to configure the IP address as follows:

1. Obtain a valid IP address for the FOX matrix switcher from the network administrator.
2. Obtain the MAC address (UID number) of the switcher from the label on its rear panel. The MAC address should have this format: 00-05-A6-xx-xx-xx.
3. If the switcher has never been configured and is still set for factory defaults, go to step 4. If not, perform a Mode 4 system reset. For detailed information on reset modes, refer to “Reset Operations” in the *FOX Matrix 320x and FOX Matrix 14400 User Guide*.

NOTE: The switcher must be configured with the factory default IP address (192.168.254.254) before the ARP command is executed, as described below.

4. At the PC, access the MS-DOS® command prompt, then enter the arp -s command. Type in the desired new IP address for the unit (obtained in step 1) and the MAC address of the unit (from the rear panel of the unit). For example:
arp -s 10.13.197.7 00-05-A6-03-69-B0 and then press <Enter>.

After receiving the arp -s command, the controller changes to the new address and starts responding to the ping requests, as described in step 5.

NOTE: You must ping the FOX matrix switcher as shown in step 5 for the IP address change to take place. The response should show the new IP address, as shown in the following figure.

5. Execute a ping command by entering “ping” followed by a space and the new IP address at the command prompt. For example:
ping 10.13.197.7

```
C:\>ping 10.13.197.7
```

```
Pinging 10.13.197.7 with 32 bytes of data:
```

```
Reply from 10.13.197.7: bytes=32 time<10ms TTL=128  
Reply from 10.13.197.7: bytes=32 time<10ms TTL=128  
Reply from 10.13.197.7: bytes=32 time<10ms TTL=128  
Reply from 10.13.197.7: bytes=32 time<10ms TTL=128
```

```
Ping statistics for 10.13.197.7:
```

```
    Packets: Sent = 4, Received = 4, Lost = 0 (0% loss),  
    Approximate round trip times in milli-seconds:  
        Minimum = 0ms, Maximum = 0ms, Average = 0ms
```

NOTE: You can reconnect using either Telnet or a web browser to verify that the update was successful.

6. After verifying that the IP address change was successful, enter and issue the “arp -d” command at the DOS prompt. For example:

```
arp -d 10.13.197.7 removes 10.13.197.7 from the ARP table  
or  
arp -d* removes all static IP addresses from the ARP table.
```

Loading the Start-up Page

NOTE: If your Ethernet connection to the matrix switcher is unstable, try turning off the proxy server in your web browser. In Microsoft Internet Explorer, click **Tools > Internet Options > Connections > LAN Settings**, uncheck the **Use a proxy server...** box, and then click **OK**.

1. Start the web browser program.
2. Click in the **Address** field.
3. Enter the Matrix IP address in the **Address** field.

NOTE: 192.168.254.254 is the factory-specified default IP address

4. Press the keyboard <Enter> key. The switcher checks to see if it is password-protected.

NOTE: The factory configured passwords for all accounts on this device have been set to the device serial number. In the event of a complete system reset, the passwords convert to the default, which is no password.

If the switcher is not password-protected, it checks and downloads the HTML start-up page. The switcher is ready for operation via HTML remote control.

If the switcher is password-protected, it downloads the Enter Network Password page.



NOTE: A User name entry is not required.

5. Enter the appropriate administrator or user password in the **Password** field and click **OK**.

The switcher downloads the HTML start-up page (see [figure 10](#) on the next page). The switcher is ready for operation via HTML remote control.

NOTE For details on operating the switcher via HTML pages, see the "HTML Operation" section in the *FOX Matrix 320x and FOX Matrix 14400 User Guide*.

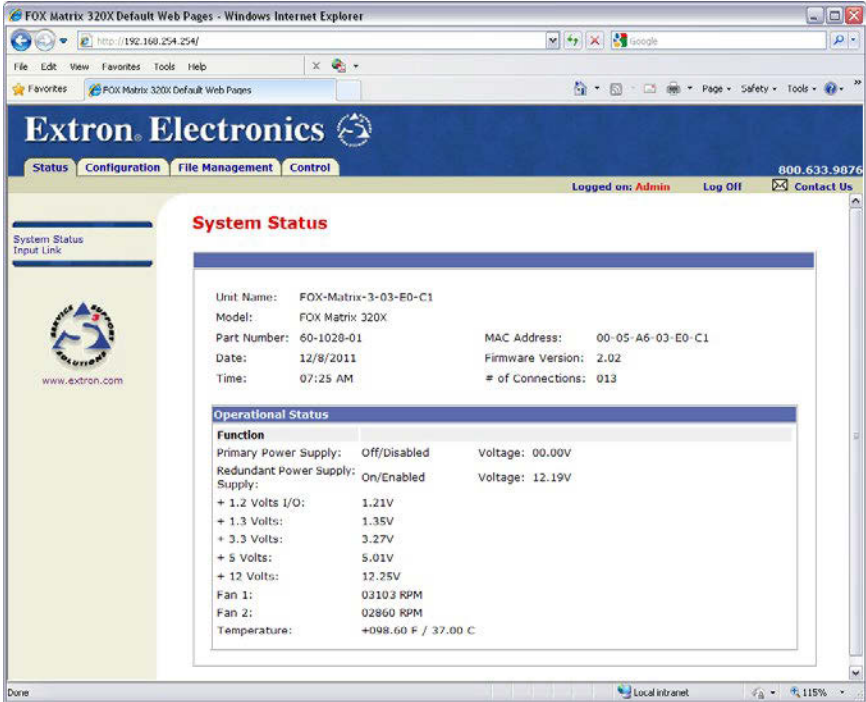

Figure 10. HTML Startup Page

Maintenance and Modifications

This section describes repairing and reconfiguring the FOX matrix switchers by replacing components. Topics that are covered include:

- [Removing and Installing an I/O Board or Blank Panel](#)
- [Removing and Installing a Power Supply Module](#)
- [Removing and Installing a Fan](#)

Removing and Installing an I/O Board or Blank Panel

Circuit boards can be added or removed to increase or decrease the I/O configuration (size) of the switcher.

WARNING: The fiber optic I/O boards of the FOX matrix switchers output continuous invisible light, which may be harmful to the eyes; use with caution.

Do not look into the fiber optic cable connectors or into the fiber optic cables themselves.

Plug the attached dust caps into the optical transceivers when the fiber cable is unplugged.

AVERTISSEMENT : L'appareil émet une lumière invisible en continu, à utiliser avec précaution.

Ne regardez pas dans les connecteurs de câble fibre optique sur le panneau arrière ou dans les câbles fibre optique eux-mêmes.

Branchez les protections contre la poussière dans l'ensemble émetteur/récepteur lorsque le câble fibre optique est débranché.

NOTES:

- On a fiber optic I/O board as delivered from Extron, all transceiver modules are configured the same: either all multimode or all singlemode. You can mix multimode and singlemode fiber optic I/O boards in a FOX matrix switcher, but ensure that you connect the proper transmission mode fiber cables to the board.
- Typically, singlemode fiber has a yellow jacket and multimode cable has an orange or cyan jacket.
- For proper cooling and air flow, boards or blank panels should be installed in all locations during normal switcher operations.
- See [A Note on I/O Boards](#) on page 5 to understand the different arrangement of connectors on the I/O boards.
- The FOX Matrix Switcher components that are user-replaceable are hot-swappable. You do not need to power down the switcher to remove or replace a component.

Remove and replace an I/O board or blank panel as follows:

1. **For an I/O board**, disconnect any connected cables.
2. Rotate the left and right knurled knobs to completely loosen the captive screws.
3. Gently pull on the knurled knobs/captive screws to loosen the board or panel from the backplane.
4. Slide the board or panel out of the chassis (see figure 11).

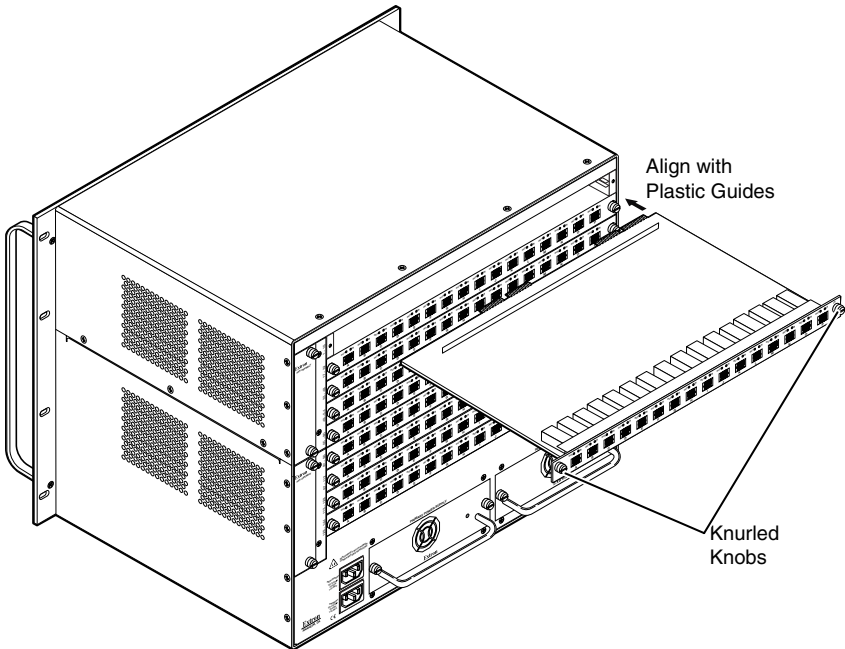

Figure 11. Remove and Replace I/O Board

ATTENTION:

- Do not touch the electronic components or the connectors on the backplane or on the circuit boards without being electrically grounded. Handle circuit boards by their edges only. Electrostatic discharge can damage circuits, even if you cannot feel, see, or hear it.
- Ne pas toucher les composants électroniques ou les connecteurs sur la carte mère ou sur les circuits imprimés sans être électriquement relié à la terre. Manipuler les circuits imprimés en les tenant seulement par leurs bords. Les décharges électrostatiques (ESD) peuvent endommager l'équipement, même si vous ne pouvez pas le sentir, le voir ou l'entendre.

5. Place the removed board on an anti-static surface or in an anti-static container.

6. **For an I/O board**, orient the board to be installed so that transceiver module A (fiber board) or input BNC A (3G/HD-SDI/SDI board) is on the left and transceiver or output BNC P is on the right.
7. **For an I/O board**, align the board with the left and right chassis guides (above).
8. Gently slide the board or blank panel into the enclosure. For an I/O board, slide the board toward the front panel until it meets resistance.
9. Gently seat the board or panel in the backplane.
10. Use a screwdriver to tighten the left and right knurled knobs/captive screws to lock the board or panel in place.

Removing and Installing a Power Supply Module

The FOX Matrix 14400 has two identical power supply modules and the FOX Matrix 320x has four identical power supply modules. Each power supply module has a 2-color LED, visible on the rear panel, that indicates the status of the power supply outputs. If the LED is lit green, the power supply is operating normally. If the LED is lit red, the supply has failed and should be replaced at the earliest opportunity. LEDs with identical meaning are also on the front panel.

ATTENTION:

- This unit uses double pole/neutral fusing. Do not operate the equipment with only one power supply cord connected.
- Cette unité utilise double pôles/fusion neutre. N'utilisez pas l'équipement avec seulement un cordon d'alimentation connecté.

NOTE: Power supply modules are not interchangeable between models.

1. Rotate the left and right knurled knobs to completely loosen the captive screws.
2. Gently pull on the handle to loosen the power supply from the backplane.
3. Slide the power supply out of the chassis (see [figure 12](#) on the next page).
4. Orient the power supply module to be installed with the LED up (FOX Matrix 320x) or to the right (FOX Matrix 14400).
5. Align the flanges on the power supply module with the power supply guides (see [figure 12](#)).
6. Gently slide the power supply module into the enclosure until the power supply meets resistance.
7. Gently seat the power supply in the backplane.
8. Use a screwdriver to tighten the left and right knurled knobs/captive screws to lock the power supply in place.

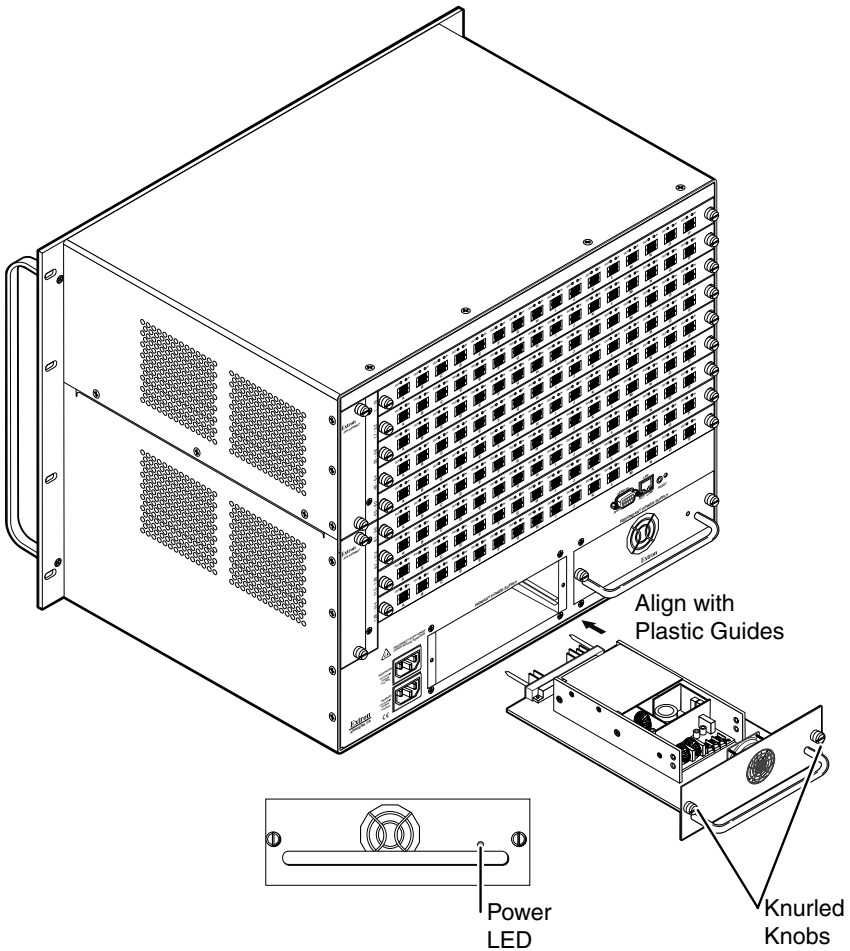

Figure 12. Power Supply Removal and Installation

Removing and Installing a Fan

The FOX Matrix 14400 has two fan modules and the FOX Matrix 320x has four fan modules. The fan modules for each model are identical and hot-swappable. If a fan fails, it should be replaced at the earliest opportunity.

NOTES:

- Fans are not interchangeable between models.
- The fans modules are hot-swappable. A fan can be removed or installed without powering down the switcher.

1. Remove and retain the two screws that secure the row identification plate (identifying rows 1 through 80, rows 81 through 144, rows 145 through 160, rows 161 through 240, or rows 241 through 320) to the fan. Retain the plate.
2. Rotate the top and bottom knurled knobs to completely loosen the captive screws.
3. Gently pull on the screws to loosen the fan from the backplane.
4. Slide the fan out of the chassis.
5. Orient the fan to be installed so that the printing on the back of the panel is right-side up.
6. Align the flanges on the fan with the top and bottom fan guides (see figure 13).
7. Gently slide the fan into the enclosure until the fan meets resistance.
8. Gently seat the fan in the backplane.
9. Use a screwdriver to tighten the top and bottom knurled knobs/captive screws to lock the fan in place.
10. Secure the row identification plate to the fan.

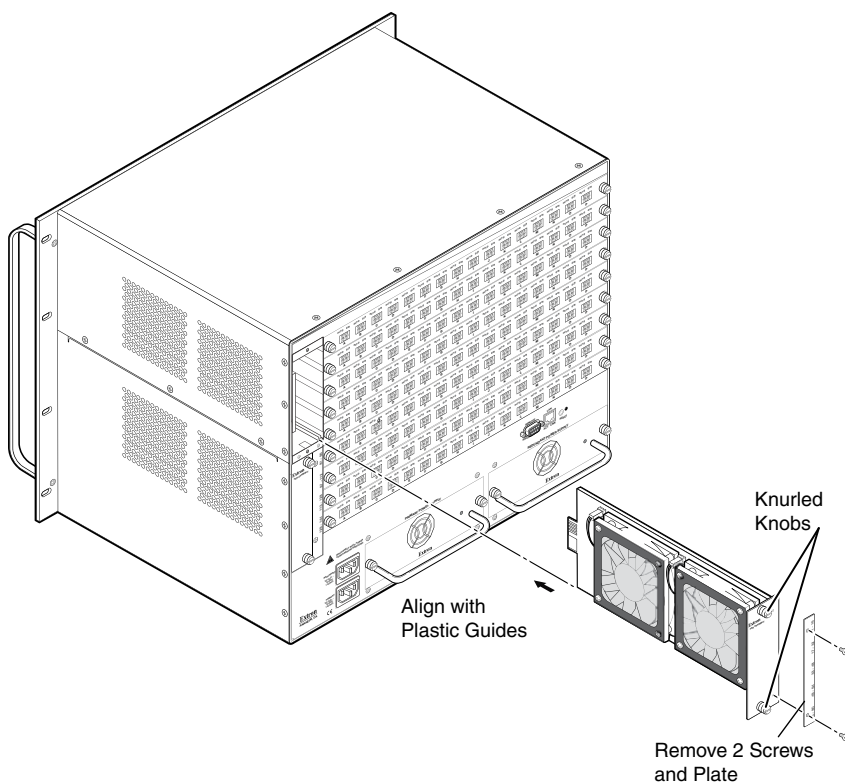

Figure 13. Fan Removal and Installation

Extron Warranty

Extron Electronics warrants this product against defects in materials and workmanship for a period of three years from the date of purchase. In the event of malfunction during the warranty period attributable directly to faulty workmanship and/or materials, Extron Electronics will, at its option, repair or replace said products or components, to whatever extent it shall deem necessary to restore said product to proper operating condition, provided that it is returned within the warranty period, with proof of purchase and description of malfunction to:

**USA, Canada, South America,
and Central America:**

Extron Electronics
1230 South Lewis Street
Anaheim, CA 92805
U.S.A.

Japan:

Extron Electronics, Japan
Kyodo Building, 16 Ichibancho
Chiyoda-ku, Tokyo 102-0082
Japan

Europe and Africa:

Extron Europe
Hanzeboulevard 10
3825 PH Amersfoort
The Netherlands

China:

Extron China
686 Ronghua Road
Songjiang District
Shanghai 201611
China

Asia:

Extron Asia
135 Joo Seng Road, #04-01
PM Industrial Bldg.
Singapore 368363
Singapore

Middle East:

Extron Middle East
Dubai Airport Free Zone
F13, PO Box 293666
United Arab Emirates, Dubai

This Limited Warranty does not apply if the fault has been caused by misuse, improper handling care, electrical or mechanical abuse, abnormal operating conditions, or if modifications were made to the product that were not authorized by Extron.

NOTE: If a product is defective, please call Extron and ask for an application engineer to receive an RA (return authorization) number. This will begin the repair process.

USA: 714.491.1500 or 800.633-9876

Europe: 31.33.453.4040

Asia: 65.6383.4400

Japan: 81.3.3511.7655

Units must be returned insured, with shipping charges prepaid. If not insured, you assume the risk of loss or damage during shipment. Returned units must include the serial number and a description of the problem, as well as the name of the person to contact in case there are any questions.

Extron Electronics makes no further warranties either expressed or implied with respect to the product and its quality, performance, merchantability, or fitness for any particular use. In no event will Extron Electronics be liable for direct, indirect, or consequential damages resulting from any defect in this product even if Extron Electronics has been advised of such damage.

Please note that laws vary from state to state and country to country, and that some provisions of this warranty may not apply to you.

