

Network Button Panels

NBP Network Button Panels

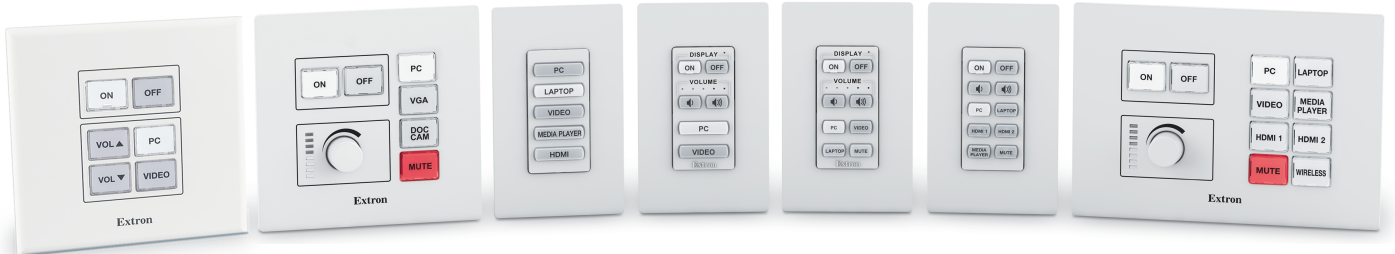

NBP 50

NBP 100

NBP 105 D

NBP 106 D

NBP 108 D

NBP 110 D

NBP 200

Safety Instructions

Safety Instructions • English

WARNING: This symbol, , when used on the product, is intended to alert the user of the presence of uninsulated dangerous voltage within the product's enclosure that may present a risk of electric shock.

ATTENTION: This symbol, , when used on the product, is intended to alert the user of important operating and maintenance (servicing) instructions in the literature provided with the equipment.

For information on safety guidelines, regulatory compliances, EMI/EMF compatibility, accessibility, and related topics, see the Extron Safety and Regulatory Compliance Guide, part number 68-290-01, on the Extron website, www.extron.com.

Sicherheitsanweisungen • Deutsch

WARNUNG: Dieses Symbol , auf dem Produkt soll den Benutzer darauf aufmerksam machen, dass im Inneren des Gehäuses dieses Produktes gefährliche Spannungen herrschen, die nicht isoliert sind und die einen elektrischen Schlag verursachen können.

VORSICHT: Dieses Symbol , auf dem Produkt soll dem Benutzer in der im Lieferumfang enthaltenen Dokumentation besonders wichtige Hinweise zur Bedienung und Wartung (Instandhaltung) geben.

Weitere Informationen über die Sicherheitsrichtlinien, Produkthandhabung, EMI/EMF-Kompatibilität, Zugänglichkeit und verwandte Themen finden Sie in den Extron-Richtlinien für Sicherheit und Handhabung (Artikelnummer 68-290-01) auf der Extron-Website, www.extron.com.

Instrucciones de seguridad • Español

ADVERTENCIA: Este símbolo, , cuando se utiliza en el producto, avisa al usuario de la presencia de voltaje peligroso sin aislar dentro del producto, lo que puede representar un riesgo de descarga eléctrica.

ATENCIÓN: Este símbolo, , cuando se utiliza en el producto, avisa al usuario de la presencia de importantes instrucciones de uso y mantenimiento recogidas en la documentación proporcionada con el equipo.

Para obtener información sobre directrices de seguridad, cumplimiento de normativas, compatibilidad electromagnética, accesibilidad y temas relacionados, consulte la Guía de cumplimiento de normativas y seguridad de Extron, referencia 68-290-01, en el sitio Web de Extron, www.extron.com.

Instructions de sécurité • Français

AVERTISSEMENT : Ce pictogramme, , lorsqu'il est utilisé sur le produit, signale à l'utilisateur la présence à l'intérieur du boîtier du produit d'une tension électrique dangereuse susceptible de provoquer un choc électrique.

ATTENTION : Ce pictogramme, , lorsqu'il est utilisé sur le produit, signale à l'utilisateur des instructions d'utilisation ou de maintenance importantes qui se trouvent dans la documentation fournie avec le matériel.

Pour en savoir plus sur les règles de sécurité, la conformité à la réglementation, la compatibilité EMI/EMF, l'accessibilité, et autres sujets connexes, lisez les informations de sécurité et de conformité Extron, réf. 68-290-01, sur le site Extron, www.extron.com.

Istruzioni di sicurezza • Italiano

AVVERTENZA: Il simbolo, , se usato sul prodotto, serve ad avvertire l'utente della presenza di tensione non isolata pericolosa all'interno del contenitore del prodotto che può costituire un rischio di scosse elettriche.

ATTENZIONE: Il simbolo, , se usato sul prodotto, serve ad avvertire l'utente della presenza di importanti istruzioni di funzionamento e manutenzione nella documentazione fornita con l'apparecchio.

Per informazioni su parametri di sicurezza, conformità alle normative, compatibilità EMI/EMF, accessibilità e argomenti simili, fare riferimento alla Guida alla conformità normativa e di sicurezza di Extron, cod. articolo 68-290-01, sul sito web di Extron, www.extron.com.

Instrukcje bezpieczeństwa • Polska

OSTRZEŻENIE: Ten symbol, , gdy używany na produkt, ma na celu poinformować użytkownika o obecności izolowanego i niebezpiecznego napięcia wewnątrz obudowy produktu, który może stanowić zagrożenie porażenia prądem elektrycznym.

UWAGI: Ten symbol, , gdy używany na produkt, jest przeznaczony do ostrzegania użytkownika ważne operacyjne oraz instrukcje konserwacji (obsługi) w literaturze, wyposażone w sprzęt.

Informacji na temat wytycznych w sprawie bezpieczeństwa, regulacji wzajemnej zgodności, zgodność EMI/EMF, dostępności i Tematy pokrewne, zobacz Extron bezpieczeństwa i regulacyjnego zgodności przewodnik, część numer 68-290-01, na stronie internetowej Extron, www.extron.com.

Инструкция по технике безопасности • Русский

ПРЕДУПРЕЖДЕНИЕ: Данный символ, , если указан на продукте, предупреждает пользователя о наличии неизолированного опасного напряжения внутри корпуса продукта, которое может привести к поражению электрическим током.

ВНИМАНИЕ: Данный символ, , если указан на продукте, предупреждает пользователя о наличии важных инструкций по эксплуатации и обслуживанию в руководстве, прилагаемом к данному оборудованию.

Для получения информации о правилах техники безопасности, соблюдении нормативных требований, электромагнитной совместимости (ЭМП/ЭДС), возможности доступа и других вопросах см. руководство по безопасности и соблюдению нормативных требований Extron на сайте Extron: www.extron.com, номер по каталогу - 68-290-01.

安全说明 • 简体中文

警告: , 产品上的这个标志意在警告用户该产品机壳内有暴露的危险电压, 有触电危险。

注意: , 产品上的这个标志意在提示用户设备随附的用户手册中有重要的操作和维护(维修)说明。

关于我们产品的安全指南、遵循的规范、EMI/EMF的兼容性、无障碍使用的特性等相关内容, 敬请访问 Extron 网站, www.extron.com, 参见 Extron 安全规范指南, 产品编号 68-290-01。

安全記事 • 繁體中文

警告: ⚠ 若產品上使用此符號, 是為了提醒使用者, 產品機殼內存在著可能會導致觸電之風險的未絕緣危險電壓。

注意 ⚠ 若產品上使用此符號, 是為了提醒使用者, 設備隨附的用戶手冊中有重要的操作和維護 (維修) 說明。

有關安全性指導方針、法規遵守、EMI/EMF 相容性、存取範圍和相關主題的詳細資訊, 請瀏覽 Extron 網站: www.extron.com, 然後參閱《Extron 安全性與法規遵守手冊》, 準則編號 68-290-01。

安全上のご注意 • 日本語

警告: この記号 ⚠ が製品上に表示されている場合は、筐体内に絶縁されていない高電圧が流れ、感電の危険があることを示しています。

注意: この記号 ⚠ が製品上に表示されている場合は、本機の取扱説明書に記載されている重要な操作と保守(整備)の指示についてユーザーの注意を喚起するものです。

安全上のご注意、法規遵守、EMI/EMF適合性、その他の関連項目については、エクストロンのウェブサイト www.extron.com より『Extron Safety and Regulatory Compliance Guide』(P/N 68-290-01) をご覧ください。

안전 지침 • 한국어

경고: 이 기호 ⚠ 가 제품에 사용될 경우, 제품의 인클로저 내에 있는 접지되지 않은 위험한 전류로 인해 사용자가 감전될 위험이 있음을 경고합니다.

주의: 이 기호 ⚠ 가 제품에 사용될 경우, 장비와 함께 제공된 책자에 나와 있는 주요 운영 및 유지보수(정비) 지침을 경고합니다.

안전 가이드라인, 규제 준수, EMI/EMF 호환성, 접근성, 그리고 관련 항목에 대한 자세한 내용은 Extron 웹 사이트(www.extron.com)의 Extron 안전 및 규제 준수 안내서, 68-290-01 조항을 참조하십시오.

Copyright

© 2019 -2020 Extron Electronics. All rights reserved. www.extron.com

Trademarks

All trademarks mentioned in this guide are the properties of their respective owners.

The following registered trademarks (®), registered service marks (SM), and trademarks (TM) are the property of RGB Systems, Inc. or Extron Electronics (see the current list of trademarks on the [Terms of Use](#) page at www.extron.com):

Registered Trademarks (®)
Extron, Cable Cubby, ControlScript, CrossPoint, DTP, eBUS, EDID Manager, EDID Minder, Flat Field, FlexOS, Glitch Free, Global Configurator, Global Scriptor, GlobalViewer, Hideaway, HyperLane, IP Intercom, IP Link, Key Minder, LinkLicense, LockIt, MediaLink, MediaPort, NAV, NetPA, PlenumVault, PoleVault, PowerCage, PURE3, Quantum, ShareLink, Show Me, SoundField, SpeedMount, SpeedSwitch, StudioStation, System <i>INTEGRATOR</i> , TeamWork, TouchLink, V-Lock, VideoLounge, VN-Matrix, VoiceLift, WallVault, WindoWall, XPA, XTP, XTP Systems, and ZipClip
Registered Service Mark (SM) : S3 Service Support Solutions
Trademarks (TM)
AAP, AFL (Accu-RATE Frame Lock), ADSP (Advanced Digital Sync Processing), Auto-Image, AVEdge, CableCover, CDRS (Class D Ripple Suppression), Codec Connect, DDSP (Digital Display Sync Processing), DMI (Dynamic Motion Interpolation), Driver Configurator, DSP Configurator, DSVP (Digital Sync Validation Processing), eLink, EQIP, Everlast, FastBite, Flex55, FOX, FOXBOX, IP Intercom HelpDesk, MAAP, MicroDigital, Opti-Torque, PendantConnect, ProDSP, QS-FPC (QuickSwitch Front Panel Controller), Room Agent, Scope-Trigger, SIS, Simple Instruction Set, Skew-Free, SpeedNav, Triple-Action Switching, True4K, True8K, Vector™ 4K, WebShare, XTRA, and ZipCaddy

FCC Class A Notice

This equipment has been tested and found to comply with the limits for a Class A digital device, pursuant to part 15 of the FCC rules. The Class A limits provide reasonable protection against harmful interference when the equipment is operated in a commercial environment. This equipment generates, uses, and can radiate radio frequency energy and, if not installed and used in accordance with the instruction manual, may cause harmful interference to radio communications. Operation of this equipment in a residential area is likely to cause interference. This interference must be corrected at the expense of the user.

NOTE: For more information on safety guidelines, regulatory compliances, EMI/EMF compatibility, accessibility, and related topics, see the [Extron Safety and Regulatory Compliance Guide](#) on the Extron website.

Battery Notice

This product contains a battery. **Do not open the unit to replace the battery.** If the battery needs replacing, return the entire unit to Extron (for the correct address, see the Extron Warranty section on the last page of this guide).

CAUTION: Risk of explosion. Do not replace the battery with an incorrect type. Dispose of used batteries according to the instructions.

ATTENTION : Risque d'explosion. Ne pas remplacer la pile par le mauvais type de pile. Débarrassez-vous des piles usagées selon le mode d'emploi.

Conventions Used in this Guide

Notifications

The following notifications are used in this guide:

ATTENTION:

- Risk of property damage.
- Risque de dommages matériels.

NOTE: A note draws attention to important information.**TIP:** A tip provides a suggestion to make working with the application easier.

Software Commands

Commands are written in the fonts shown here:

```
^ARMerge Scene, ,Op1 scene 1,1 ^B 51 ^W^C  
[01] R0004 00300 00400 00800 00600 [02] 35 [17] [03]
```

```
Esc [X1] * [X17] * [X20] * [X23] * [X21] CE ←
```

NOTE: For commands and examples of computer or device responses mentioned in this guide, the character “0” is used for the number zero and “O” is the capital letter “o.”

Computer responses and directory paths that do not have variables are written in the font shown here:

```
Reply from 208.132.180.48: bytes=32 times=2ms TTL=32  
C:\Program Files\Extron
```

Variables are written in slanted form as shown here:

```
ping xxx.xxx.xxx.xxx -t  
SOH R Data STX Command ETB ETX
```

Selectable items, such as menu names, menu options, buttons, tabs, and field names are written in the font shown here:

```
From the File menu, select New.  
Click the OK button.
```

Specifications Availability

Product specifications are available on the Extron website, www.extron.com.

Extron Glossary of Terms

A glossary of terms is available at <http://www.extron.com/technology/glossary.aspx>.



Contents

Introduction 1

Before You Begin.....	1
What This Guide Covers.....	1
Conventions Used in This Guide.....	1
About the Network Button Panels.....	1
Decorator-style Models.....	2
US Gang Models.....	2
Cable Cubby Model.....	3
Features.....	3
Application Diagrams.....	4
PC System Requirements.....	6

Hardware Features and Installation – Wall-mountable Models..... 7

Overall Configuration Procedure.....	8
Step 1: Get Ready.....	9
Preparation Checklist.....	9
Accessibility and Americans with Disabilities Act (ADA) Compliance.....	9
Step 2: Prepare the Installation Site.....	10
Site Preparation.....	11
Step 3: Change Buttons, Button Labels, a Bezel, or Wallplate (optional).....	12
Instructions for Decorator-style Models.....	12
Instructions for US Gang Models.....	14
Step 4: Cable All Devices.....	15
Rear and Side Panel Features and Cabling (Decorator-style and US Gang Models).....	16
Step 5: Set up the NBP for Network Communication.....	18
Step 6: Configure the System.....	18
Step 7: Test and Troubleshoot.....	18
Step 8: Complete the Physical Installation.....	19
Mounting.....	19

Hardware Features and Installation – NBP 1200C..... 22

Overall Configuration Procedure, NBP 1200C...	23
Step 1: Get Ready (NBP 1200C).....	24
Preparation Checklist.....	24
Accessibility and Americans with Disabilities Act (ADA) Compliance.....	24
Included Parts.....	25
Step 2: Prepare the Installation Site, Cut the Table or Furniture.....	25
Prepare the Site.....	26
Cut the Table.....	26
Step 3: Assemble AAP, Pass-through, and Power Modules.....	27
Assemble Connectivity Modules.....	27
Step 4: Change Buttons (optional).....	28
Step 5: Install Modules and a Retractor Bracket.....	29
Retractor Bracket.....	29
AAP Module, Cable Pass-through Module, and Power Module.....	30
Step 6: Mount the NBP 1200C to the Table.....	31
Insert the NBP 1200C Enclosure Into the Table.....	31
Under the Table, Adjust the Side Clamps on the Enclosure.....	31
Step 7: Install Retractors.....	32
Step 8: Install Cables in the Cable Cubby.....	32
Step 9: Cable the NBP 1200C and Other Devices in the System.....	33
Bottom Panel Features and Cabling (NBP 1200C).....	33
Step 10: Set up the NBP 1200C for Network Communication.....	35
Step 11: Configure the System.....	35
Step 12: Test and Troubleshoot.....	35

Operation 36

Front Panel Features (All Models) and NBP 1200C Bottom Panel Features	36
Wallplates and Bezels	39
Buzzer (Decorator-style Models and NBP 1200C)	39
Buttons.....	39
Volume Controls and LEDs	40
Reset Features and Resetting the Unit.....	42
Locating the Reset Button and LED.....	42
Resetting the Unit	42

**Software-Based
Configuration and Control 44**

Configuration and Control: an Overview.....	44
Basic Setup Steps: a Guide to this Section and Other Resources	45
Downloading the Software and Getting Started	45
Locating Software, Firmware, and Driver Files on the Extron Website.....	45
Things to Do After Installing GC and Before Starting a Project.....	47
Using GC: Helpful Tips	47
Troubleshooting	48
Power Connections	48
Data Connections.....	48
Device Control Connections and Configuration.....	49

Reference Information 50

Network Port Requirements.....	50
Secure Sockets Layer (SSL) Certificates	50
IEEE 802.1X Certificates	51
Certificate File Requirements.....	51
Private Key File Requirements.....	52

Firmware Updates..... 53

Determining the Firmware Version.....	53
Using Toolbelt Software	53
Using a Browser	53
Updating the Firmware	54
Locating and Downloading the Firmware	54
Installing firmware	54

Introduction

This section covers the following basic information you should know about this guide and the product before installation:

- [Before You Begin](#)
- [About the Network Button Panels](#)
- [Application Diagrams](#)
- [PC System Requirements](#)

Before You Begin

What This Guide Covers

This user guide provides instructions for an experienced installer to install an Extron Network Button Panel (NBP). This guide includes detailed information and recommends best practices for cabling the NBP. It provides a brief overview of the configuration process, and reference information.

Configure the IP-related settings of the NBP using Toolbelt software. Then you can configure the control processor and overall system using Extron Global Configurator Professional (GC Professional) or Global Configurator Plus (GC Plus), or program them using Global Scriptor. The system configuration includes button configurations for the NBPs.

This guide does not contain instructions on detailed software-related setup steps or details of configuration within the software. Those are covered in the help files for each software package or scripting program. The software help files describe how to use each program to download drivers, add AV devices to a configuration, configure basic functions, and set up schedules, macros, e-mail alerts, button configurations, and the like.

Conventions Used in This Guide

- Throughout this guide a Network Button Panel is also referred to as an “NBP” or “button panel.”
- Global Configurator software is referred to as “GC,” which can be run as Global Configurator Professional or Global Configurator Plus.
- The GlobalViewer Enterprise application is sometimes referred to as “GVE.”

About the Network Button Panels

The NBP Network Button Panels allow users to remotely control AV equipment in conjunction with an Extron IP Link Pro control processor or HCR 102 receiver (part of an HC 400 Series system). This equipment includes, but is not limited to, display devices, switches, source devices, and various other items such as lights, a projector lift, or a screen motor.

See the help files for the configuration and programming software to determine how many NBPs can be included in a system.

The IP settings for NBPs are configured via Toolbelt software. Configure button behavior as part of the system configuration you create within a Global Configurator project or Global Scriptor project. The project configuration is saved, built, and uploaded into the IPCP Pro or IPL Pro control processor or the HCR 102 receiver.

Decorator-style Models

The NBP 105 D, NBP 106 D, NBP 108 D, and NBP 110 D feature soft backlit buttons, fit into a standard US one-gang junction box or mud ring, and include a decorator-style wallplate.

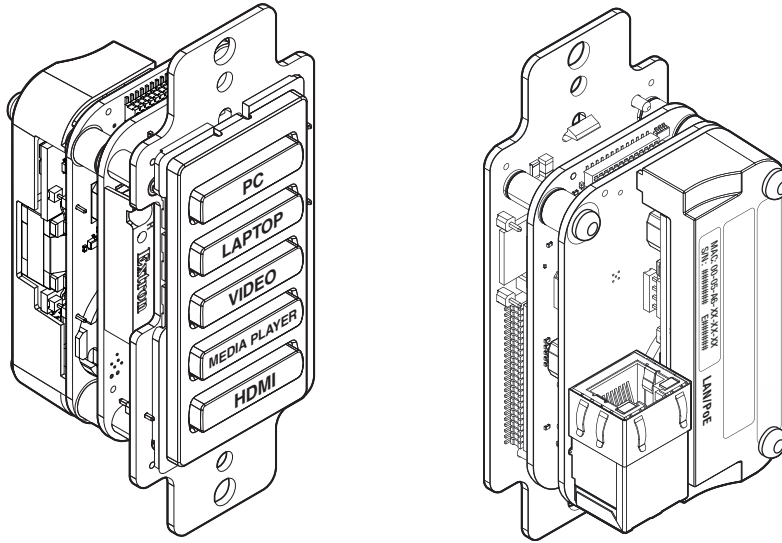

Figure 1. NBP 105 D Front (Left) and Rear (Right) Views Without Wallplate

US Gang Models

The NBP 50, NBP 100, and NBP 200 feature hard, translucent buttons that can easily be relabeled. These models fit into a standard US two-gang (NBP 50, NBP 100) or three-gang (NBP 200) junction box or mud ring.

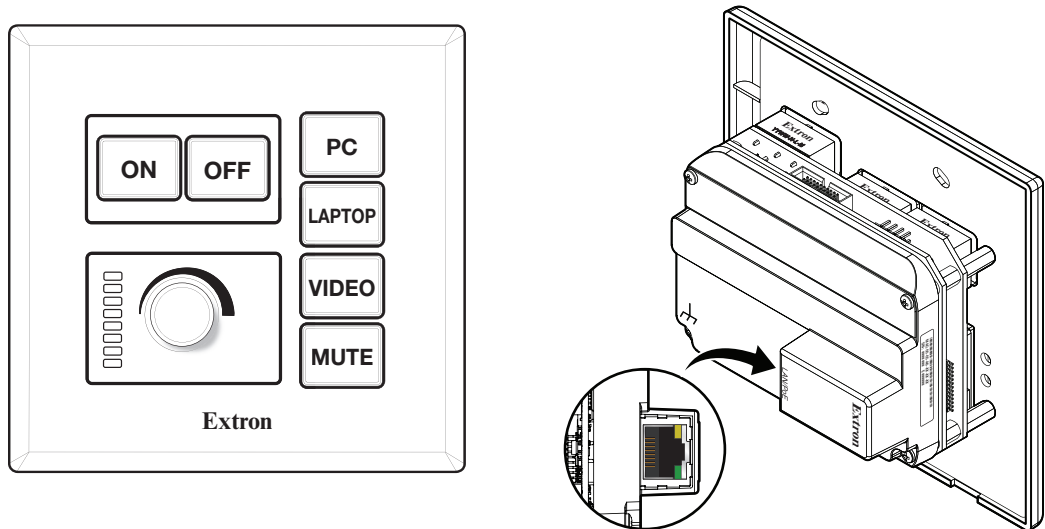

Figure 2. NBP 100 Front (Left) and Rear (Right) Views

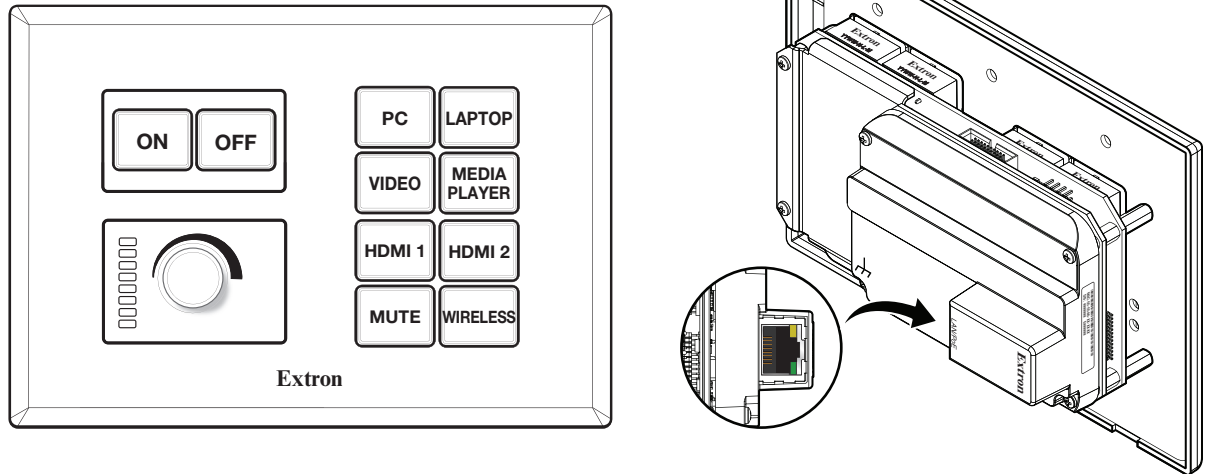

Figure 3. NBP 200 Front (Left) and Rear (Right) Views

Cable Cubby Model

The NBP 1200C features soft backlit buttons. It is mounted in a Cable Cubby enclosure so it can be integrated into a table, desk, or lectern.

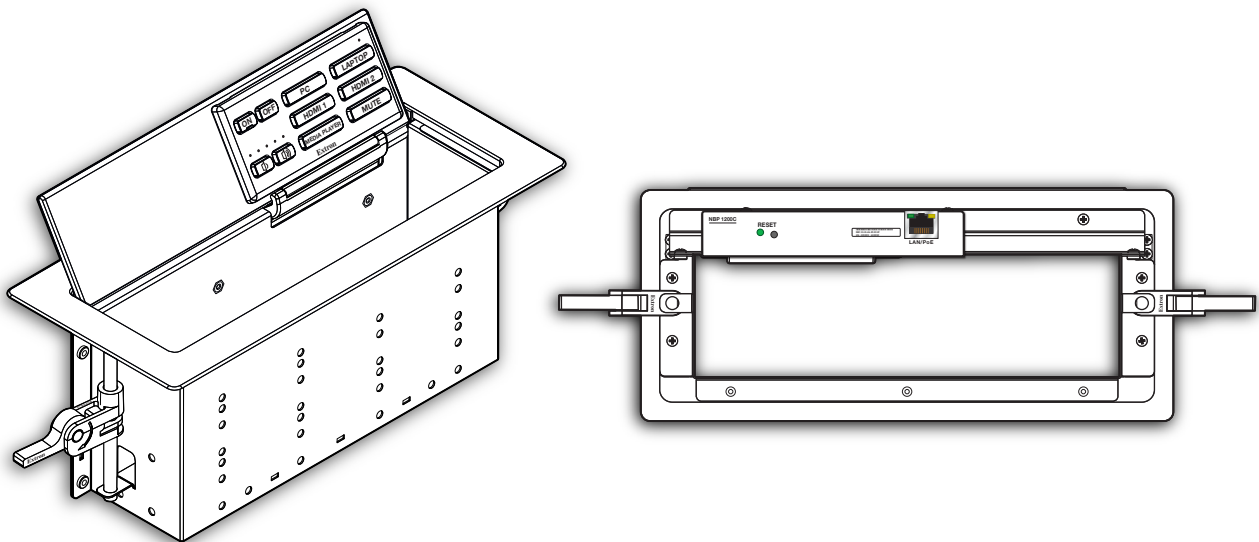

Figure 4. NBP 1200C Front (Left) and Bottom (Right)

Features

General features

- **Configurable buttons** — The system configuration sets button illumination (levels and whether each button is lit steadily or blinking) and functions (commands, macros, and so forth).
- **A variety of mounting options** — The NBP can be mounted in furniture or a wall, in a lectern, table, or in a surface mount box, depending on the model.
- **Power over Ethernet (PoE)** — The NBPs support power over Ethernet, providing the unit with both power and an Ethernet signal over a single connector.

Network and configuration features

- **Global compatibility** — The NBP's use industry standard Ethernet communication protocols, including DHCP, DNS, HTTP, HTTPS, ICMP, NTP, SFTP, SMTP, SNMP, SSH, TCP/IP, and UDP/IP.
- **Network connection** — The NBP's support 10Base-T up to 100Base-T Ethernet communication.
- **Additional security features** — Each control processor can use the included Secure Sockets Layer (SSL) certificate or a user-supplied, customized security certificate (see [Secure Sockets Layer \(SSL\) Certificates](#) on page 50). IEEE 802.1X Authentication is also supported in these devices and in the control systems with which they work, once enabled. For details see [IEEE 802.1X Certificates](#) on page 51.

Application Diagrams

The following figures provide examples of NBP button panels integrated into AV systems.

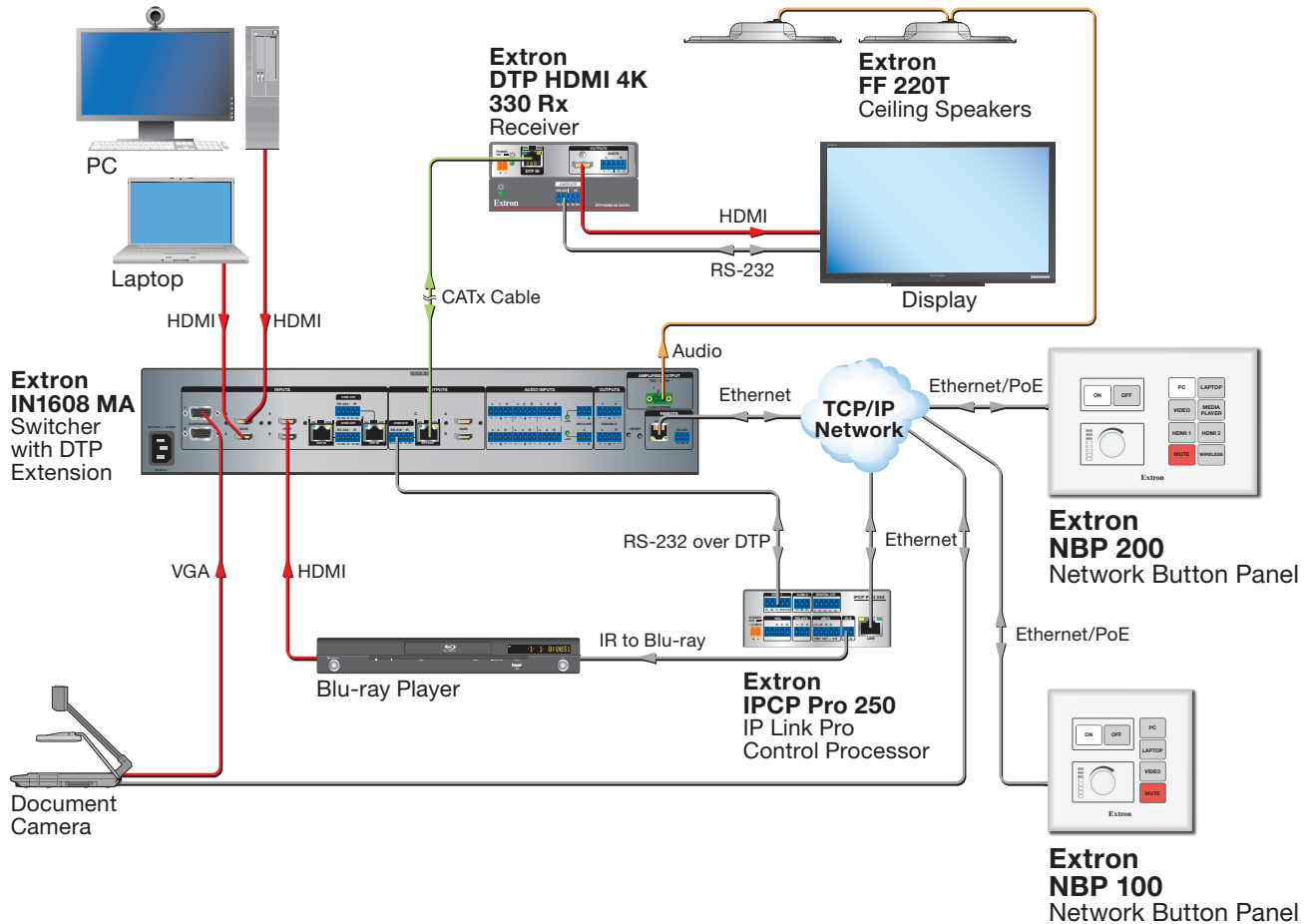

Figure 5. An NBP 100 and NBP 200 Application

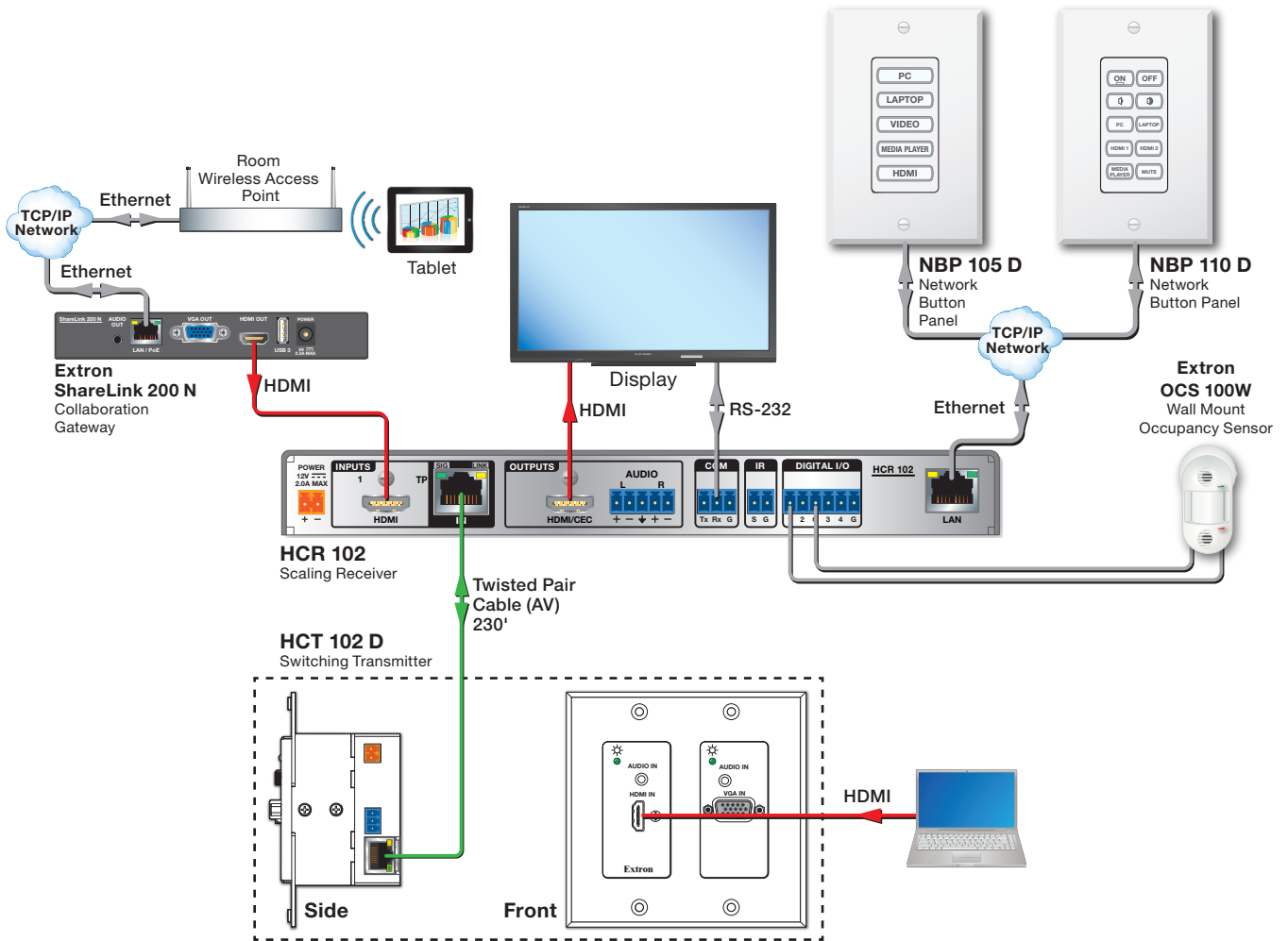

Figure 6. A Collaboration System Featuring Network Button Panels

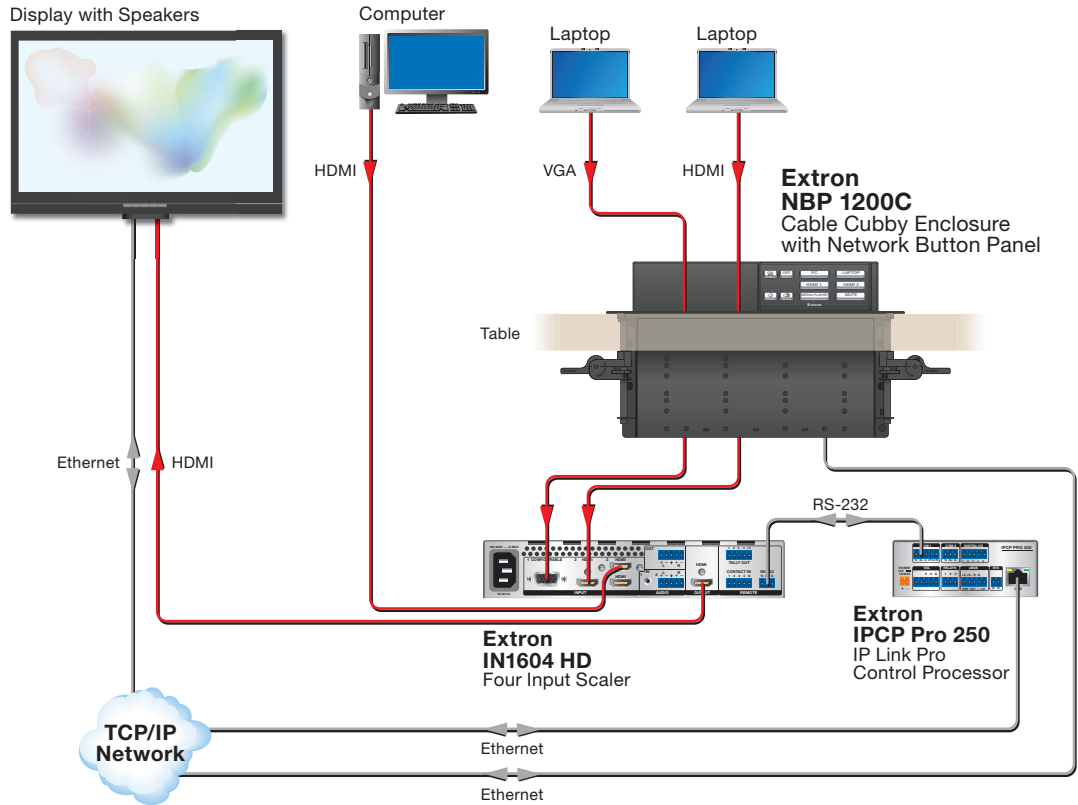

Figure 7. A Typical NBP 1200C Application

PC System Requirements

To find the minimum hardware and software requirements for the PC you use to configure or program the system:

- Visit the **Download** page (<http://www.extron.com/download/index.aspx>) on the Extron website and navigate to the web page for the specific software package (such as Global Configurator). Minimum system requirements are listed in the description section. In some cases, minimum device firmware version requirements are also listed there.
- If system requirements are not listed on the software package web page, contact an Extron support representative.

Hardware Features and Installation – Wall-mountable Models

This section covers the following material for the decorator-style and US gang models:

- **Overall Configuration Procedure**
- **Step 1: Get Ready**
- **Step 2: Prepare the Installation Site**
- **Step 3: Change Buttons, Button Labels, a Bezel, or Wallplate (optional)**
- **Step 4: Cable All Devices**
- **Step 5: Set up the NBP for Network Communication**
- **Step 6: Configure the System**
- **Step 7: Test and Troubleshoot**
- **Step 8: Complete the Physical Installation**
- **Mounting**

Overall Configuration Procedure

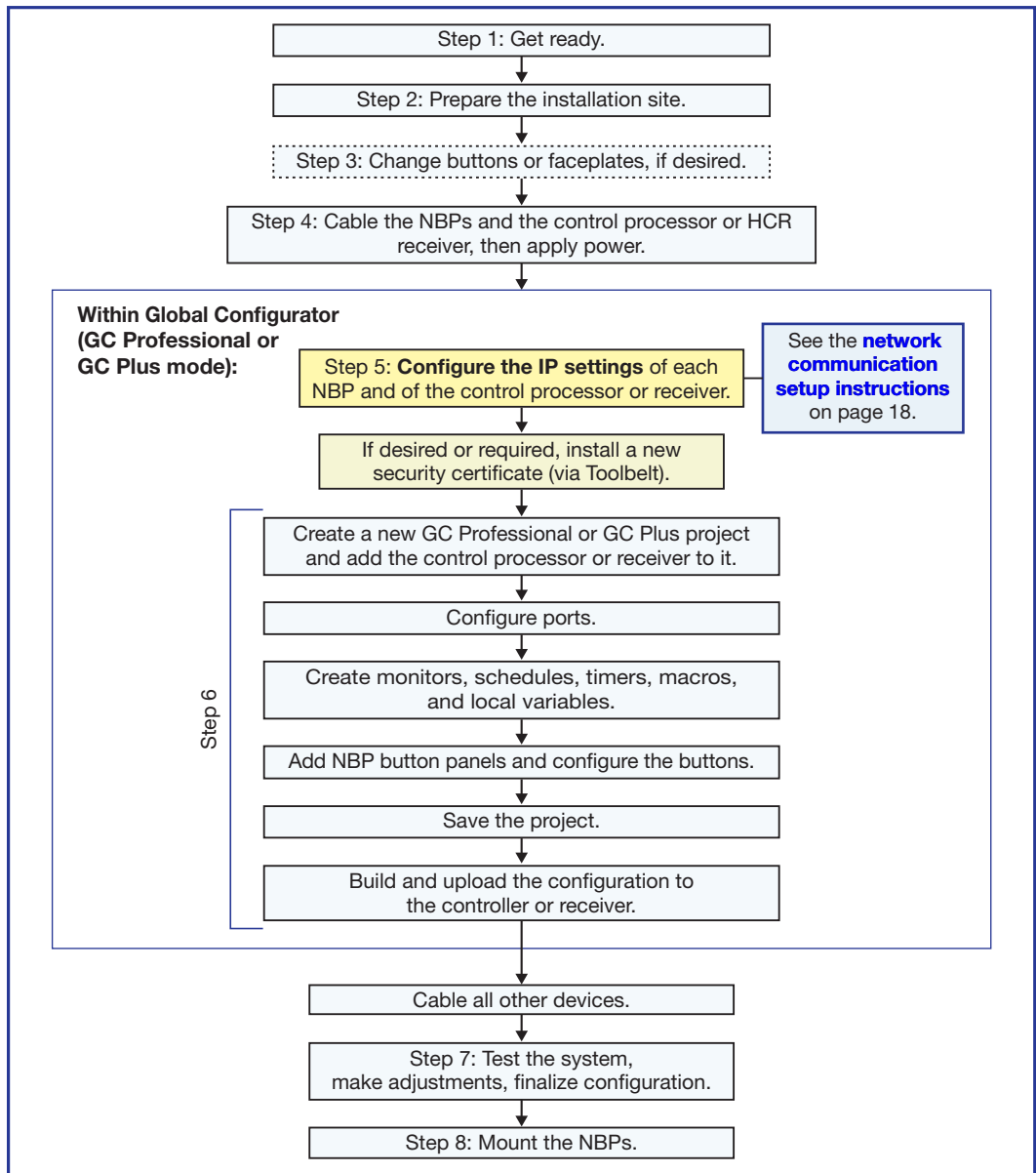

Figure 8. Overall Installation and Configuration Steps

Step 1: Get Ready

Preparation Checklist

Use the following checklist to prepare for the installation.

- Familiarize yourself with the features of the button panel (see [Front Panel Features \(All Models\) and NBP 1200C Bottom Panel Features](#) on page 36, [Rear and Side Panel Features and Cabling \(Decorator-style and US Gang Models\)](#) on page 16, and [Bottom Panel Features and Cabling \(NBP 1200C\)](#) on page 33)
- Download and install the latest version of the software, firmware, and device drivers needed to discover, configure, or program the control processor or HCR receiver (or other Extron collaboration system control product) to interact with the NBPs and control the connected AV products. See the *IPCP Pro Series User Guide*, *IPL Pro Series User Guide*, or *HC 400 Series User Guide* (available from www.extron.com) for details on software and drivers.
- Obtain network information for the unit from the network administrator. You need the following details for each IP Link Pro device, including the IPCP Pro, IPL Pro, HCR 102 (or other collaboration system receiver), and each NBP:
 - DHCP setting (on or off)
 - Subnet mask
 - Username
 - Device (NBP) IP address
 - Gateway IP address
 - Passwords

NOTE: If DHCP is on, you do not need the IP addresses and subnet mask.

- Write down the MAC address of each IP Link Pro device (such as the NBP) to be used.
- Obtain model names and setup information for the AV devices to be controlled in the system.
- Each NBP button panel comes with a factory-installed Secure Sockets Layer (SSL) security certificate. If you intend to install a different SSL certificate, contact your IT department to obtain the certificate or for instructions on how to obtain one. See [Secure Sockets Layer \(SSL\) Certificates](#) on page 50 for requirements and guidelines regarding SSL certificates.
- For systems that will use IEEE 802.1X security, obtain a PEM-encoded security certificate and private key (see [IEEE 802.1X Certificates](#) on page 51) from your IT department.

Accessibility and Americans with Disabilities Act (ADA) Compliance

When planning where to install the NBP, consider factors affecting accessibility of the controller such as height from the floor, distance from obstructions, and how far a user must reach to press the buttons. For guidelines, see sections 307 (“Protruding Objects”) and 308 (“Reach Ranges”) of the *2010 ADA Standards for Accessible Design* available at <http://www.ada.gov/regs2010/2010ADASTandards/2010ADASTandards.pdf>.

Step 2: Prepare the Installation Site

Steps and hardware required depend on the model being installed (see [Site Preparation](#) on page 11 for details).

ATTENTION:

- Installation and service must be performed by authorized personnel only.
- L'installation et l'entretien doivent être effectués uniquement par un technicien qualifié.
- Extron recommends installing the NBP into a grounded, UL Listed electrical junction box.
- Extron recommande d'installer le NBP dans une boîte de dérivation électrique mise à la terre, certifiée UL.
- If the NBP will be installed into fine furniture, it is best to hire a licenced, bonded craftsperson to cut the access hole and perform the physical installation so the surface will not be damaged.
- S'il est prévu d'installer le NBP dans du beau mobilier, il est préférable de faire appel à un artisan autorisé et qualifié pour couper le trou d'accès et réaliser l'installation de telle façon que la surface ne soit pas endommagée.
- Follow all national and local building and electrical codes that apply to the installation site.
- Respectez tous les codes électriques et du bâtiment, nationaux et locaux, qui s'appliquent au site de l'installation.
- For the installation to meet UL requirements and to comply with National Electrical Code (NEC), the NBP must be installed in a UL Listed junction box. The end user or installer must furnish the junction box. It is not included with the unit.
- Pour que l'installation respecte les exigences UL et soit conforme au National Electrical Code (NEC) américain, le NBP doit être installé dans une boîte de dérivation certifiée UL. Il incombe à l'utilisateur final ou à l'installateur de fournir la boîte de dérivation. Cet équipement n'est pas inclus avec l'unité.

NOTES:

- Read any installation instructions and regulatory guidelines that come with the mounting devices (raceway, junction box, surface mounting box, mud ring) before installing the mounting device.
- If the NBP is not mounted to a grounded metal junction box or a grounded metal equipment rack, Extron recommends connecting the unit to an earth ground to protect the unit from electrostatic discharge. For details, see the [grounding instructions](#) on page 15.

Select and prepare the site before cabling the NBP. This may include cutting a hole in the installation surface or installing a cabling raceway, running the cables to that site, installing the wall box, and pulling cables through it.

Site Preparation

The NBP button panels fit standard US junction boxes or mud rings.

Model	Gang Size
NBP 105 D, NBP 106 D, NBP 108 D, NBP 110 D	1
NBP 50, NBP 100	2
NBP 200	3

Optional mud rings, UL Listed junction boxes, external junction boxes, and surface mounting boxes are available for use with the button panels. Read any installation instructions and UL guidelines that come with the mounting devices, then install the box or mud ring in the opening at the installation site.

To prepare the site:

1. Using the size of the junction box or mud ring for reference, cut the hole in the mounting surface. Protect the surface prior to and during cutting so the surface is not damaged.

NOTES:

- The approximate cutout dimensions for an Extron-supplied two-gang mud ring are 4.1" W x 3.75" H (104 mm W x 95 mm H).
- If mounting the NBP 100 directly to the mounting surface, cut a hole of approximately 3.6" W x 2.9" H (91 mm W x 74 mm H).

2. Run cables to the mounting location, leaving enough slack for device installation.
3. Install the junction box or mud ring into the wall or furniture.
4. Secure the cables with a clamp for strain relief and so they do not slip back down into the wall or furniture.

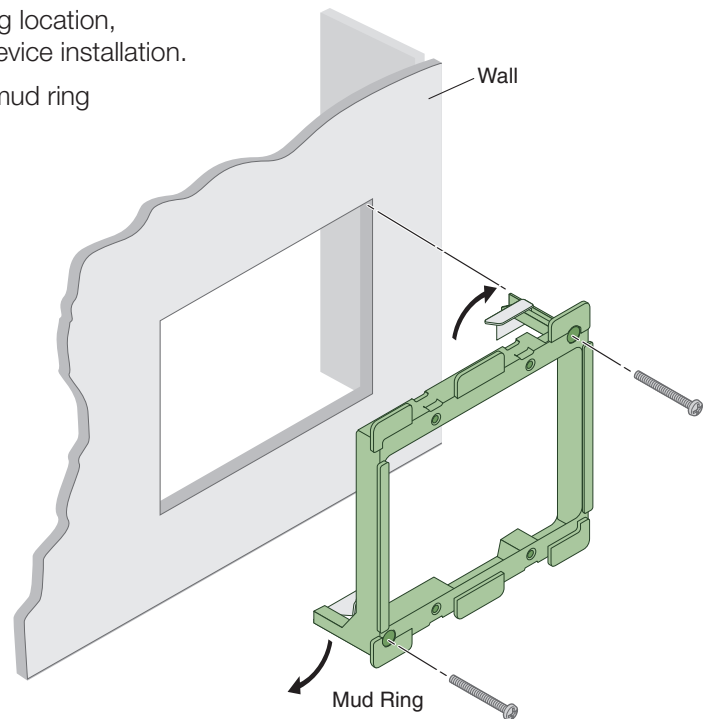

Figure 9. Installing a Mud Ring

Step 3: Change Buttons, Button Labels, a Bezel, or Wallplate (optional)

Instructions for Decorator-style Models

If desired, replace one or more buttons or button pairs using available additional buttons. Optional button kits are available in various languages. Wallplates and bezels are available in black, as well.

NOTE: A custom button builder tool is available at <http://www.extron.com/product/custombuttonbuilder/index.aspx> where you can order standard stock buttons or custom-labeled buttons for the NBP decorator-style models.

Replacing Buttons or a Bezel on a Decorator-style NBP

The bezel must be removed to access buttons.

To replace the buttons or the bezel:

1. If already installed, remove the wallplate. Save the two screws for later use.
2. Remove the bezel as follows:
 - a. Insert the tip of a small, flat-bladed screwdriver (such as an Extron Tweeker) through one of the slots at the top or bottom of an NBP, as shown in figure 10 at right.
 - b. Angle the screwdriver to press gently down on the tab to release and pry the bezel from the mounting plate.
 - c. If the bezel has not fully detached from the circuit board, repeat steps **2a** and **2b** with the hole and tabs at the opposite end of the mounting plate.
 - d. Lift the bezel away from the mounting plate.
3. Remove any buttons to be replaced as follows:
 - a. Press the button or button pair from the front of the bezel out through the back of its bezel opening. If necessary, pull the buttons out gently from the back.

NOTE: The smaller buttons are arranged in pairs connected by a rubbery membrane.

 - b. If you are replacing the faceplate, repeat step **3a** until all buttons are removed.
 - c. Set the removed buttons aside for later use.
4. Insert a button or button pair as follows:

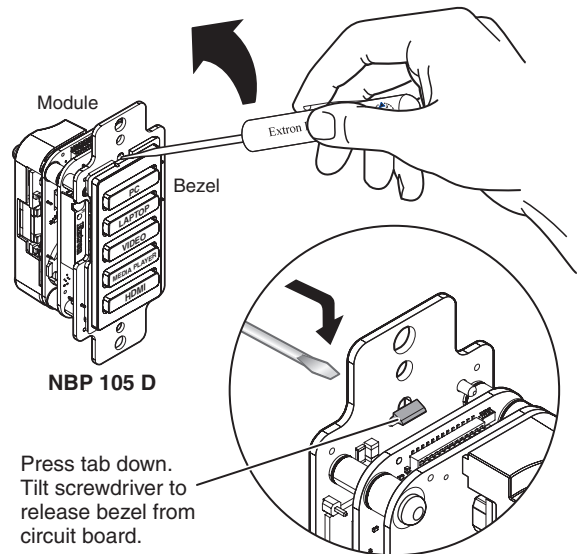

Figure 10. Using a Screwdriver to Release the Bezel Tabs, Rear View

- a. Insert a new button or button pair from the back into the appropriate opening in the original or the replacement bezel.
- b. Align the two pegs in the upper left and lower right corners of the button or button pair (see figure 11) with the corresponding holes in the bezel. Press the button or buttons into the bezel so the buttons and pegs are seated into the holes and bezel opening.
- c. Repeat steps **4a** and **4b** for any additional buttons to be replaced or installed.

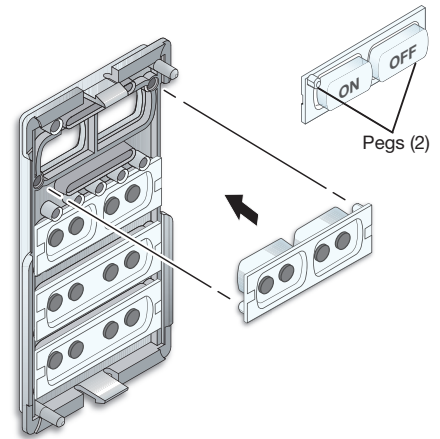

Figure 11. Inserting Buttons

- 5. Reattach the original bezel or attach the replacement bezel to the NBP as follows:
 - a. Align the tabs (at top and bottom) and pegs (at upper left and lower right corners) on the back of the bezel with the slots and holes on front of the mounting plate.
 - b. Gently but firmly press the bezel against the mounting plate until the tabs and pegs are inserted into the slots and holes, and the tabs click into place.

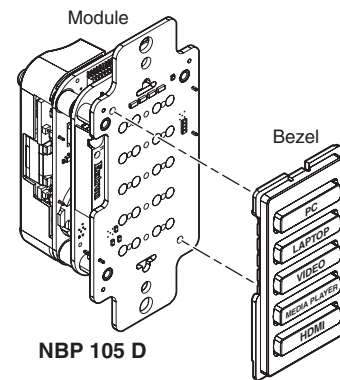

Figure 12. Aligning and Reattaching the Bezel

Instructions for US Gang Models

The faceplate, button labels, and knob can easily be changed at any time. Some button labels ship with the unit. You can create and print your own customized labels using Extron Button Label Generator software, which is available in the software [Download Center](#) page on the Extron website.

Removing and replacing a faceplate

To replace a faceplate:

1. Remove the faceplate by holding the body of the unit with one hand, gripping the sides of the faceplate with the other hand, and pulling the faceplate away from the unit.
2. Align the openings of the new faceplate with the buttons and knob and with the LEDs and place the faceplate against the unit. The magnetic catches fasten the faceplate onto the unit.

TIP: You can wait until the unit is mounted to the junction box or mud ring before placing the new faceplate on the unit.

Replacing button labels

To change a button label:

1. Remove the faceplate as mentioned in step 1 of “Removing and replacing a faceplate”, above.
2. For each button label to be replaced, gently separate the button lens cap from its white diffuser. To do this, insert the end of the provided Extron removal (pry) tool into the corner notch and gently twist the tool (see figure 13, ①).
3. Remove the label insert from the translucent button cap.
4. Select one of the button labels from the printed label sheets included with the unit. Remove the label from its backing and remove the clear, protective film from the front of the label.
5. Insert the button label into the button cap (see ②). Check for correct label orientation.
6. Align the cap with the white diffuser and the panel opening, and press the clear cap into place on the button.
7. Reattach the faceplate to the unit (see step 2 in “Removing and replacing a faceplate”, above).

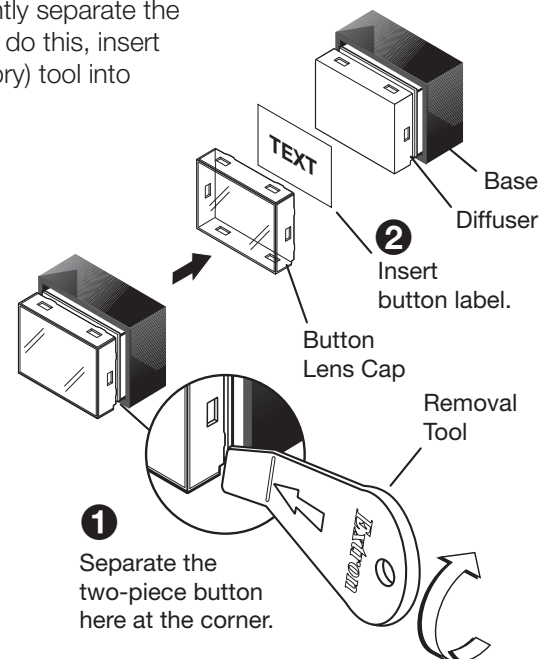

Figure 13. Replacing Button Labels on a US Gang Model NBP

Changing a knob

To change a knob:

1. Remove the faceplate as described in step 1 of “Removing and replacing a faceplate”, above.
2. Firmly grasp the knob and pull it away from the NBP.
3. Align the ridge inside the new knob with the channel on the knob control and allow the magnet in the knob to snap into place.
4. Reattach the faceplate to the unit (see step 2 in “Removing and replacing a faceplate”).

Step 4: Cable All Devices

1. For the US gang models, if the button panel is not mounted to a grounded metal junction box or a grounded metal equipment rack, Extron recommends connecting the unit to an earth ground to protect the unit from electrostatic discharge.

To ground the unit:

- a. Securely terminate a grounding cable with a ring terminal.
- b. Remove the grounding screw in the lower left corner of the rear panel, insert the grounding cable, replace and securely fasten the screw (see the figure at right). Do not over-tighten the screw. Maximum torque is 2 inch-pounds (0.2 Newton-meter).
- c. Connect the other end of the grounding cable to an earth ground.

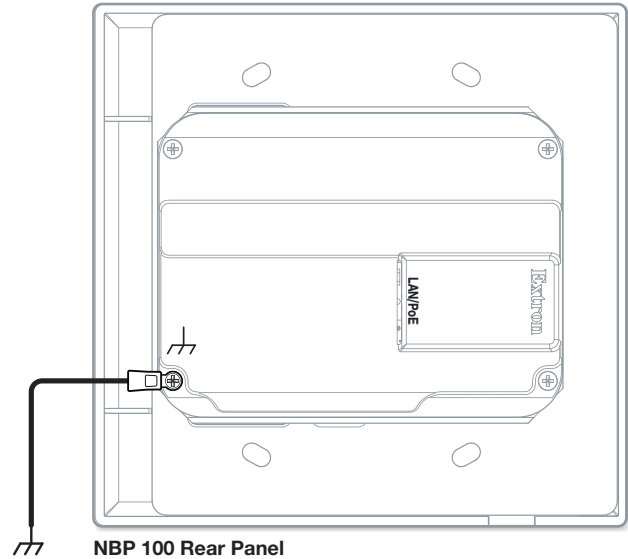

Figure 14. Connecting a Grounding Wire to the NBP

2. For all models, connect the NBP to the network (see [Rear and Side Panel Features and Cabling \(Decorator-style and US Gang Models\)](#) on the next page), and cable devices to the control processor or HCR receiver (see the user guide for the appropriate device).

NOTE: Examples on the following pages show the NBP 105 D. However, connector wiring functions are identical for all models.

3. Connect power cords and power on the control processor or receiver and other devices.

Rear and Side Panel Features and Cabling (Decorator-style and US Gang Models)

LAN (Ethernet) and PoE connector and LEDs — Connect the unit to a network via this connector for control and Power over Ethernet. Use the following diagrams as a guide.

Network connection lets you configure the control system and the NBP. For details of communication protocols, ports, and services used, see the *Pro Series Control Product Network Ports and Licenses Guide*, part 68-2961-01, available at www.extron.com.

All NBP one-gang decorator-style models have identical rear panel features.

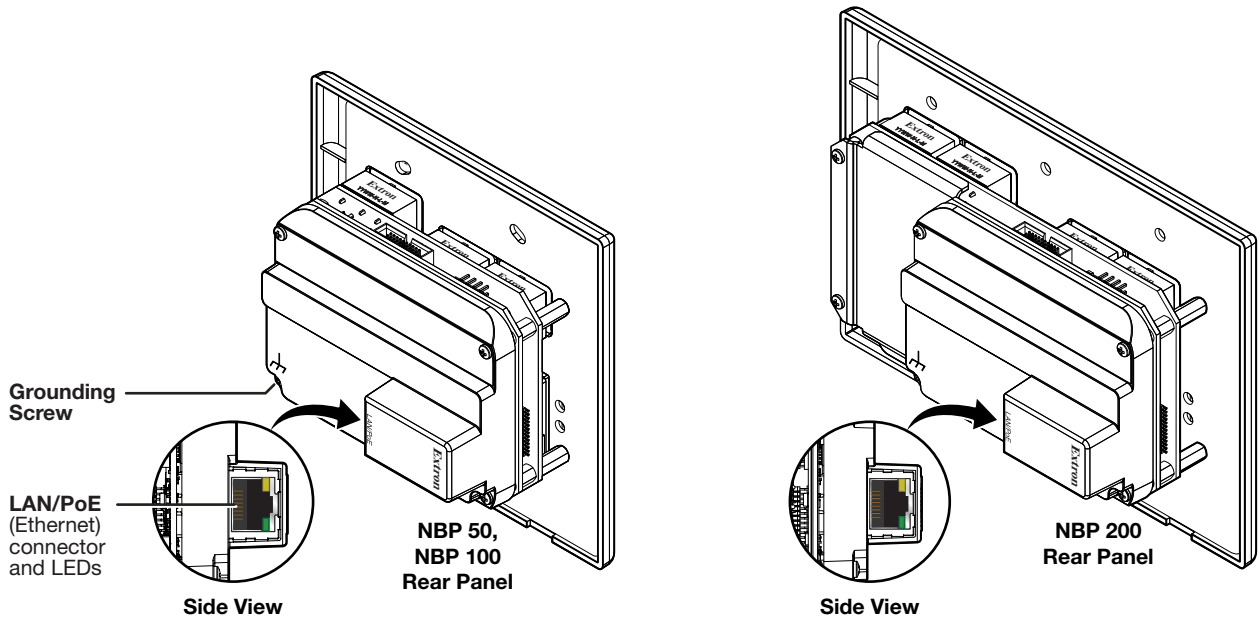

Figure 15. Rear Panel Features — US Gang Models

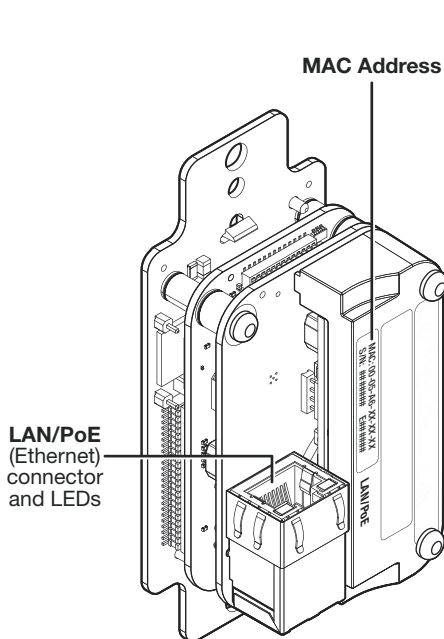

Figure 16. Rear Panel Features — Decorator-style NBPs

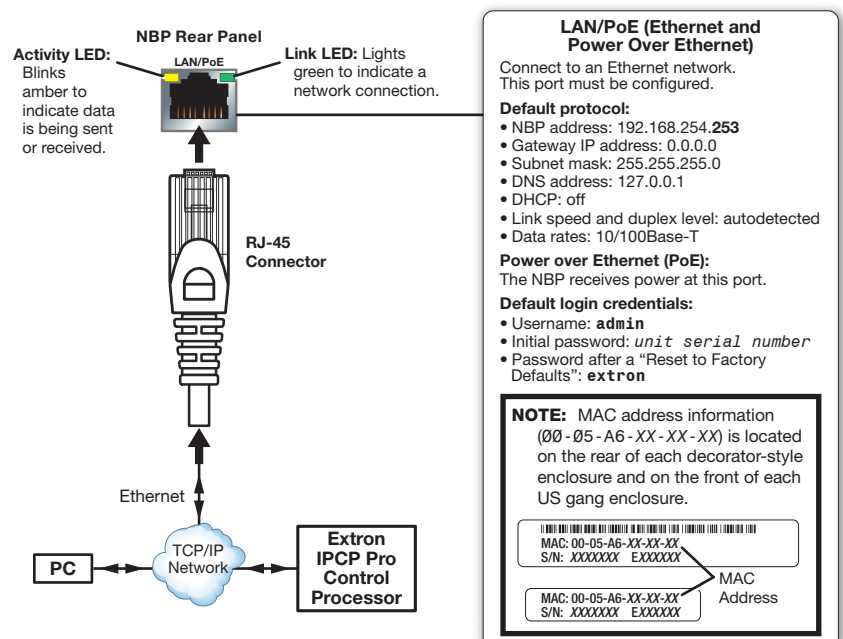

Figure 17. LAN/PoE Port Details

IMPORTANT NOTES:

- The factory configured password for this device has been set to the device serial number. Passwords are case sensitive. Performing a Reset to Factory Defaults (see [Resetting the Unit](#) on page 42) sets the password to **extron**.
- DHCP is off by default.

ATTENTION:

- Power over Ethernet (PoE) is intended for indoor use only. It is to be connected only to networks or circuits that are not routed to the outside plant or building.
- L'alimentation via Ethernet (PoE) est destinée à une utilisation en intérieur uniquement. Elle doit être connectée seulement à des réseaux ou des circuits qui ne sont pas routés au réseau ou au bâtiment extérieur.
- If not provided with a power supply, this product is intended to be supplied by a UL Listed power source marked "Class 2" or "LPS" and rated output 48 VDC (PoE), minimum 0.35 A, or 56 VDC (PoE), minimum 0.8 A.
- Si le produit n'est pas fourni avec une source d'alimentation, il doit être alimenté par une source d'alimentation certifiée UL de classe 2 ou LPS, avec une tension nominale 48 Vcc (PoE), 0,35 A minimum, ou 56 VDC (PoE), 0,8 A minimum.
- The installation must always be in accordance with the applicable provisions of National Electrical Code ANSI/NFPA 70, article 725 and the Canadian Electrical Code part 1, section 16. The power supply shall not be permanently fixed to building structure or similar structure.
- Cette installation doit toujours être conforme aux dispositions applicables du Code américain de l'électricité (National Electrical Code) ANSI/NFPA 70, article 725, et du Code canadien de l'électricité, partie 1, section 16. La source d'alimentation ne devra pas être fixée de façon permanente à une structure de bâtiment ou à une structure similaire.
- The Network Button Panels are intended to be used with Extron Electronics UL Listed products only.
- L'utilisation des claviers de commande réseau est prévue uniquement avec des produits certifiés UL Extron Electronics.

Cabling:

- For 10Base-T (10 Mbps) networks, use a CAT 3 or better cable.
- For 100Base-T (max. 155 Mbps) networks, use a CAT 5 cable.

Activity LED (on connector) — This yellow LED blinks to indicate network activity.

Link LED (on connector) — This green LED lights to indicate a good network connection.

MAC address — This is the unique user hardware ID number (Media Access Control [MAC] address) of the unit (for example, 00-05-A6-05-1C-A0). You may need this address during configuration. The label is on the back panel for decorator-style models (see [figure 16](#) on page 16) and on the front panel for the NBP 100 and NBP 200 (see [figure 39](#) on page 38).



Step 5: Set up the NBP for Network Communication

1. Connect the NBP button panel and the PC to be used for setup to the same Ethernet subnetwork.
2. Start Toolbelt and use it to set DHCP on or to set the IP address, subnet, gateway IP address, DHCP status, and related settings. Network setup is essential prior to configuration.

Use the flowchart at right as a guide to setting up the unit for network use.

NOTES:

- If using a host name instead of an IP address the user must enter a qualified host name (*Username.HostName.Domain*). For example: `somename.somedomain.com`.
- If using 802.1X security, see the *Extron 802.1X Technology Reference Guide* and the *Toolbelt Help* file for additional details on system setup.

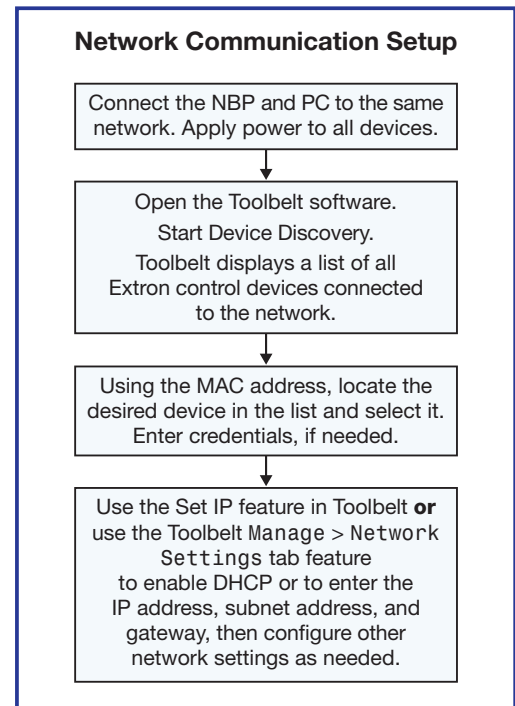

Figure 18. Network Setup

Step 6: Configure the System

Use Global Configurator (GC Plus or GC Professional) to configure the IPCP Pro control processor, IPL Pro control processor, or HCR receiver. Alternatively, use Global Scriptor to program the IPCP Pro or IPL Pro control processor. That configuration sets the control and monitoring behavior for all the AV devices and control accessories (such as the NBP button panels) in the system. An outline of the main configuration and programming steps is included in the user guide for the control device.

NOTE: See the *Toolbelt Help File*, *Global Configurator Help File*, and *Global Scriptor Help File* as needed for step-by-step instructions and detailed information. The help file for GC includes an introduction to the software, and how to start a project and configuration.

When configuration or programming is completed, save the project or program script, then build and upload the system configuration to the control processor or receiver.

Step 7: Test and Troubleshoot

1. Test the system (see the *IPCP Pro Series User Guide*, *IPL Pro Series User Guide*, or *HC 400 Series User Guide* for an outline of the system testing and troubleshooting procedure).
2. Make adjustments to wiring or configuration as needed. Remember that the rear panel port on the button panel is not accessible after the NBP is mounted.

Step 8: Complete the Physical Installation

Mount the unit to a wall or furniture (see “Mounting”, below). Before mounting the NBP, make sure that the Ethernet cable has been fed through the wall or furniture and is connected to the NBP rear panel.

NOTES:

- Extron recommends taking safety precautions to avoid electrostatic discharge issues during installation.
- For best results, Extron recommends grounding the NBP if the junction box or mud rings are not already grounded (see the [grounding instructions](#) on page 15).

Mounting

Mount the NBP as follows:

1. Insert the cabled NBP into the mud ring or junction box within the wall or furniture, aligning the mounting holes in the NBP with those in box or mud ring.
2. Secure the NBP to the junction box, wall or surface mounting box, or mud ring as follows (see figures 19 to 22):
 - a. **For decorator-style models:** Insert the included screws through the mounting holes at the top and bottom of the NBP and into the corresponding threaded holes in the box or mud ring (see figure 19 and figure 20).

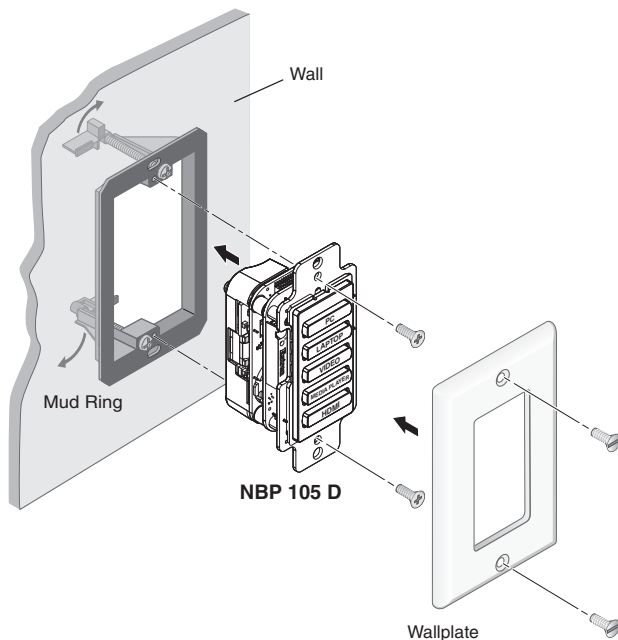

Figure 19. Installing the NBP 105 D in a Mud Ring

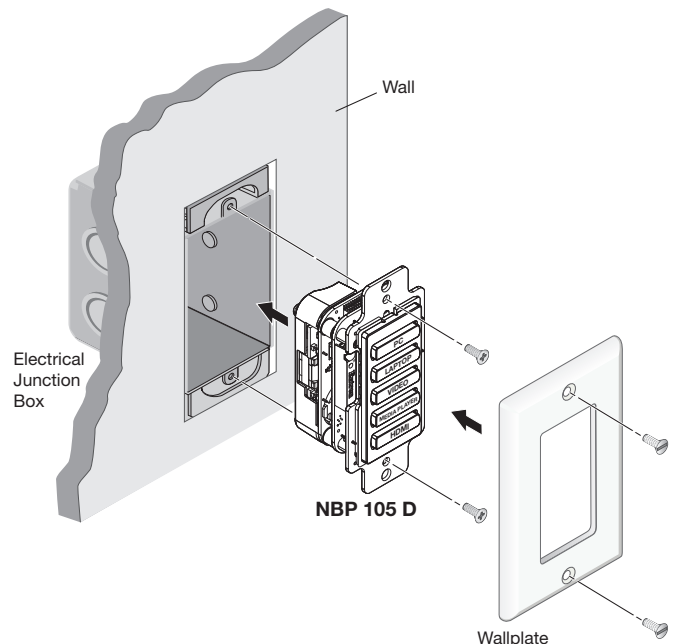

Figure 20. Installing the NBP 105 D in a Junction Box

For US gang models: Insert the included screws through the mounting holes at the top and bottom of the unit, through the plastic spacer (if not using a mud ring), and into the corresponding threaded holes in the box or mud ring (see figure 21 and figure 22).

NOTE: If the unit is not installed in a mud ring, you must install the plastic spacer. The spacer positions the unit to allow the magnetic faceplate to attach properly and securely.

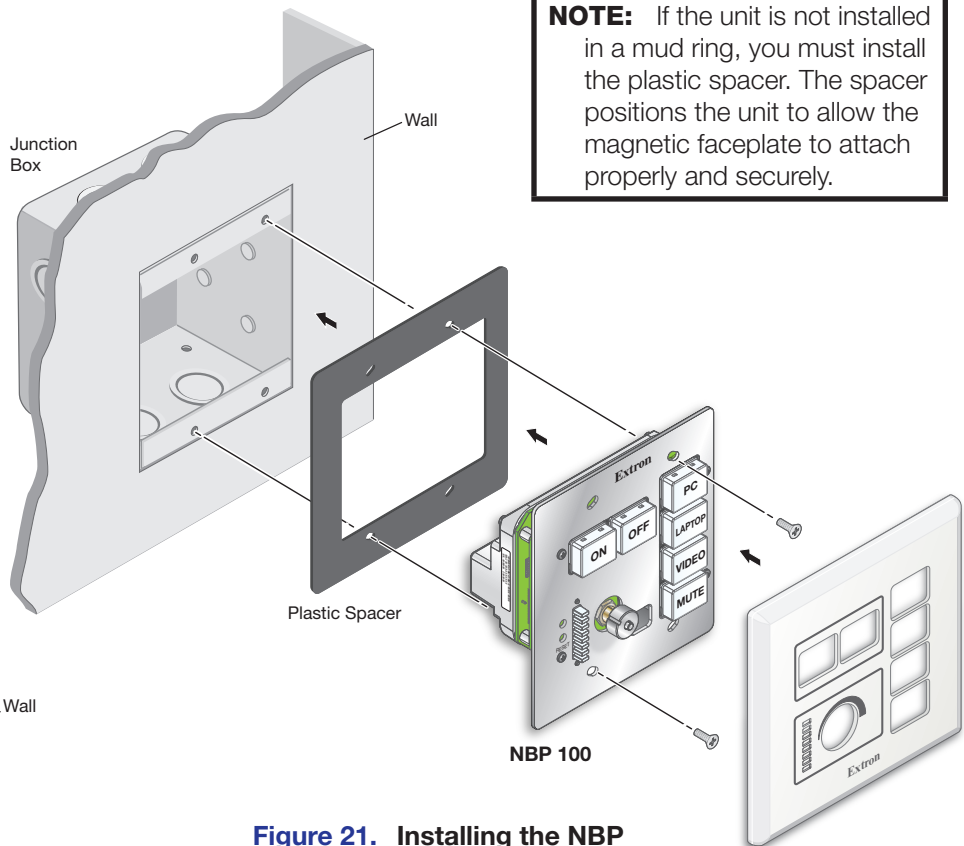

Figure 21. Installing the NBP in a Junction Box

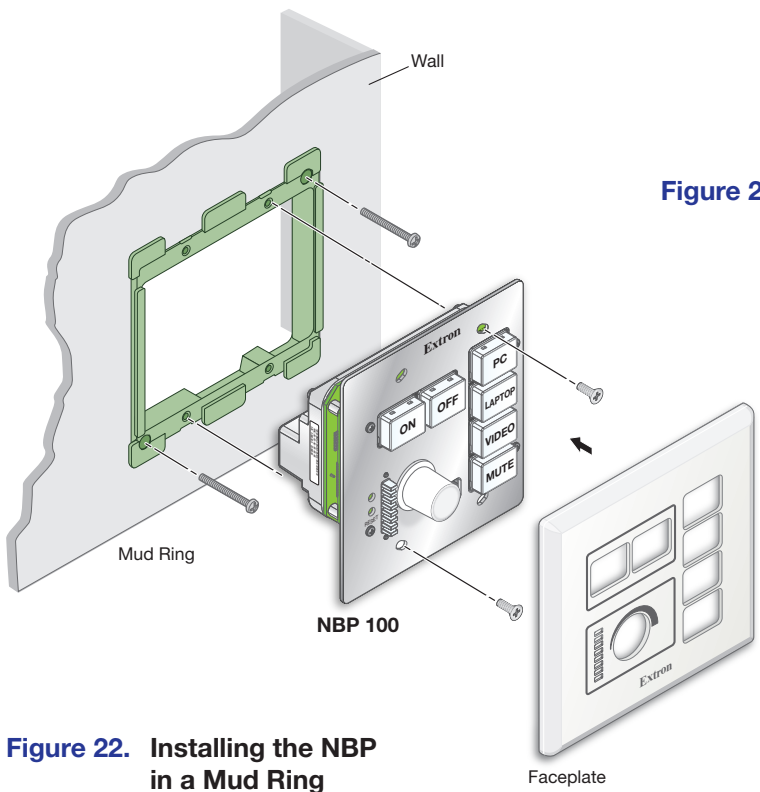

Figure 22. Installing the NBP in a Mud Ring

NOTE: Extron recommends taking precautions to avoid electrostatic discharge issues during installation.

b. Using a Phillips screwdriver, lightly tighten the mounting screws until snug.

ATTENTION:

- Do **not** overtighten the screws.
- Veuillez à **ne pas** trop serrer les vis.

3. Attach the wallplate to the NBP
 - **For decorator-style models:** Insert the included screws through the circular holes in the wallplate and the tabs on the NBP (see [figure 19](#) and [figure 20](#) on page 19). Hand tighten the screws using a flat bladed screwdriver until snug.
 - **For US gang models:** Align the faceplate openings with the buttons, knob, and LEDs, and place the faceplate against the unit (see [figure 21](#) and [figure 22](#) on the previous page). The magnetic catches fasten the faceplate onto the front of the unit.

Hardware Features and Installation — NBP 1200C

This section covers the following material for the NBP 1200C:

- [Overall Configuration Procedure, NBP 1200C](#)
- [Step 1: Get Ready \(NBP 1200C\)](#)
- [Step 2: Prepare the Installation Site, Cut the Table or Furniture](#)
- [Step 3: Assemble AAP, Pass-through, and Power Modules](#)
- [Step 4: Change Buttons \(optional\)](#)
- [Step 5: Install Modules and a Retractor Bracket](#)
- [Step 6: Mount the NBP 1200C to the Table](#)
- [Step 7: Install Retractors](#)
- [Step 8: Install Cables in the Cable Cubby](#)
- [Step 9: Cable the NBP 1200C and Other Devices in the System](#)
- [Step 10: Set up the NBP 1200C for Network Communication](#)
- [Step 11: Configure the System](#)
- [Step 12: Test and Troubleshoot](#)

Overall Configuration Procedure, NBP 1200C

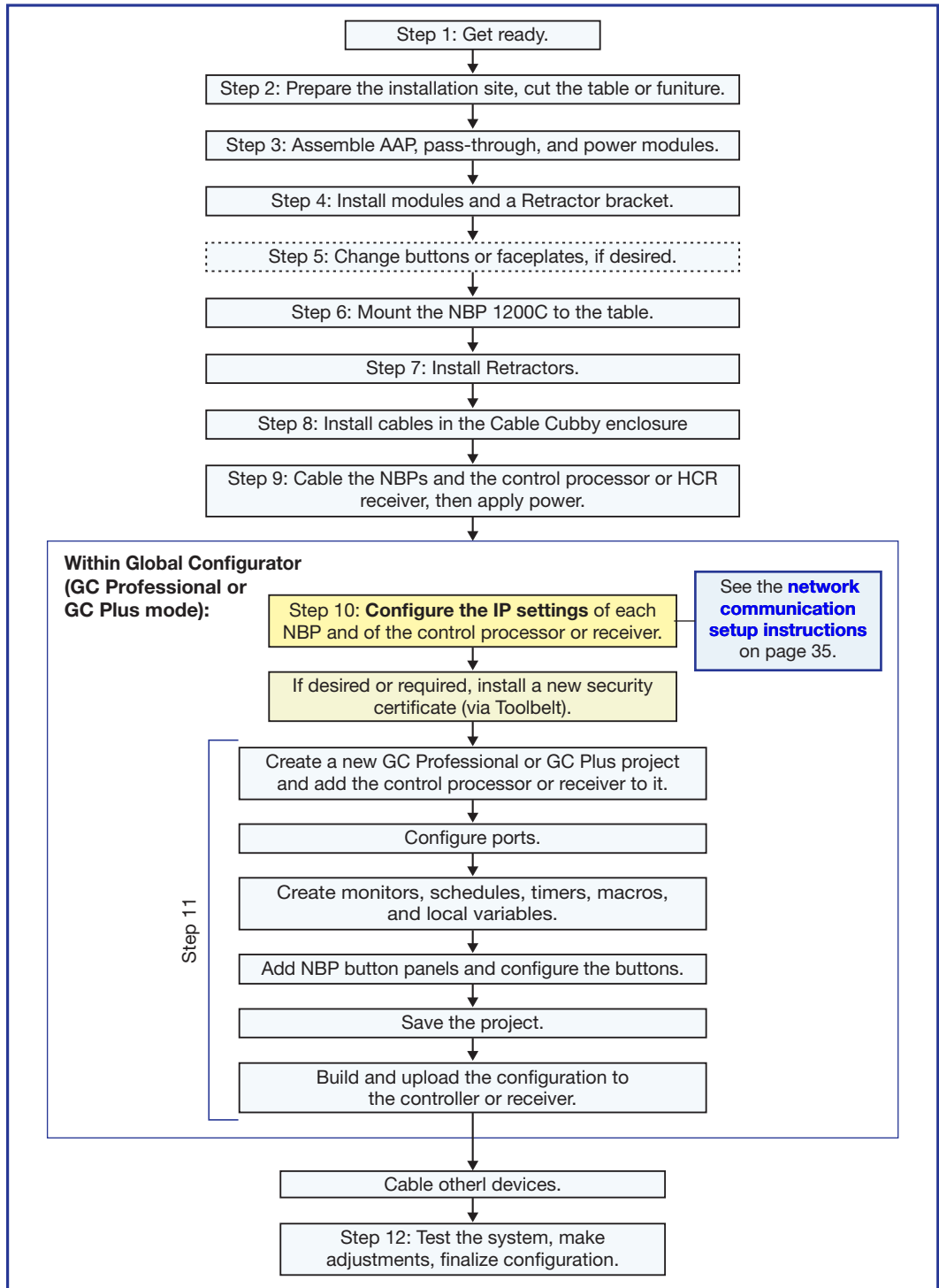

Figure 23. Overall Installation and Configuration Steps for the NBP 1200C

Step 1: Get Ready (NBP 1200C)

Preparation Checklist

Use the following checklist to prepare for the installation.

- Familiarize yourself with the features of the button panel (see **Front Panel Features (All Models) and NBP 1200C Bottom Panel Features** on page 36 and **Bottom Panel Features and Cabling (NBP 1200C)** on page 33)
- Download and install the latest version of the software, firmware, and device drivers needed to discover, configure, or program the control processor or HCR receiver (or other Extron collaboration system control product) to interact with the NBPs and control the connected AV products. See the *IPCP Pro Series User Guide*, *IPL Pro Series User Guide*, or *HC 400 Series User Guide* (available from www.extron.com) for details on software and drivers.
- Obtain network information for the unit from the network administrator. You need the following details for each IP Link Pro device, including the IPCP Pro, IPL Pro, HCR 102 (or other collaboration system receiver), and each NBP:
 - DHCP setting (on or off)
 - Subnet mask
 - Username
 - Device (NBP) IP address
 - Gateway IP address
 - Passwords

NOTE: If DHCP is on, you do not need the IP addresses and subnet mask.

- Write down the MAC address of each IP Link Pro device (such as the NBP) to be used.
- Obtain model names and setup information for the AV devices to be controlled in the system.
- Each NBP button panel comes with a factory-installed Secure Sockets Layer (SSL) security certificate. If you intend to install a different SSL certificate, contact your IT department to obtain the certificate or for instructions on how to obtain one. See **Secure Sockets Layer (SSL) Certificates** on page 50 for requirements and guidelines regarding SSL certificates.
- For systems that will use IEEE 802.1X security, obtain a PEM-encoded security certificate and private key (see **IEEE 802.1X Certificates** on page 51) from your IT department.
- Verify that you have all the included parts (see **Included Parts** on page 25) and have all the necessary tools for installing the Cable Cubby.
- Before cutting a hole in any furniture, select the best location for the NBP 1200C.
 - Ensure that the product is oriented so that the lid opens in the desired direction.
 - Ensure there is enough space for all the system cables and components, including cable retractors, if they are to be installed.
- Check all relevant regulations.

Accessibility and Americans with Disabilities Act (ADA) Compliance

When planning where to install the NBP, consider factors affecting accessibility of the controller such as height from the floor, distance from obstructions, and how far a user must reach to press the buttons. For guidelines, see sections 307 (“Protruding Objects”) and 308 (“Reach Ranges”) of the *2010 ADA Standards for Accessible Design* available at <http://www.ada.gov/regs2010/2010ADASTandards/2010ADASTandards.pdf>.

Included Parts

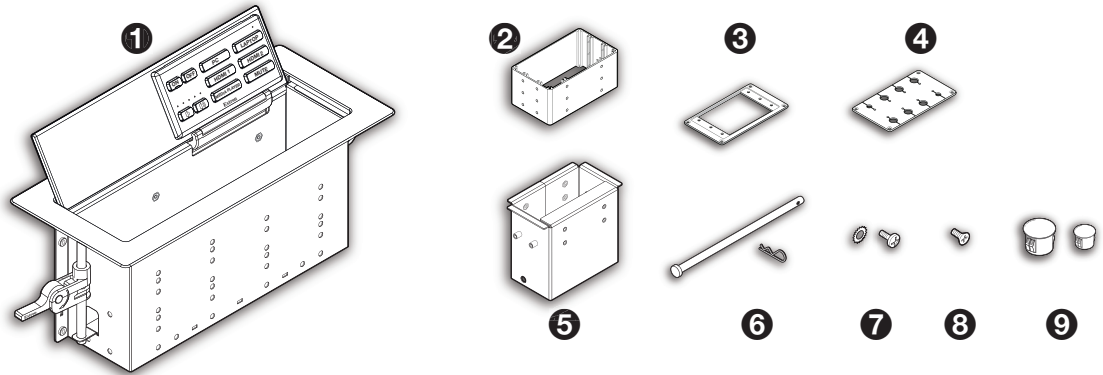

Figure 24. NBP 1200C Included Parts

Item	Qty	Item	Qty	Item	Qty
1 NBP 1200C	1	6 Retractor pin and clip	1	9 Grommet hole plugs	6 (3/8") 2 (1/4")
2 Connectivity bracket	1*	7 #6-32 pan-head mounting screws and star washers	8	Extron removal tool (not shown)	1
3 AAP frame plate	1	8 #4-40 module screws	8	Extron Tweezer (small screwdriver) (not shown)	1
4 Cable grommet plate	1			Blank buttons (not shown)	1
5 Retractor bracket	1				

NOTE: *A single connectivity bracket is provided. It can be used with either the AAP frame plate or the cable grommet plate.

Step 2: Prepare the Installation Site, Cut the Table or Furniture

ATTENTION:

- Installation and service must be performed by authorized personnel only.
- L'installation et l'entretien doivent être effectués uniquement par un technicien qualifié.
- If the NBP will be installed into fine furniture, it is best to hire a licensed, bonded craftsman to cut the access hole and perform the physical installation so the surface will not be damaged.
- S'il est prévu d'installer le NBP dans du beau mobilier, il est préférable de faire appel à un artisan autorisé et qualifié pour couper le trou d'accès et réaliser l'installation de telle façon que la surface ne soit pas endommagée.
- Follow all national and local building and electrical codes that apply to the installation site.
- Respectez tous les codes électriques et du bâtiment, nationaux et locaux, qui s'appliquent au site de l'installation.

NOTE: Extron recommends connecting the unit to an earth ground to protect the unit from electrostatic discharge. Use the provided #6-32 star washers and mounting screws to connect the ground wire to the CableCubby enclosure.

Select and prepare the site before cabling the NBP. This includes cutting a hole in the installation surface, running the cables to that site, and installing the Cable Cubby enclosure and its components (connectivity brackets, AAP modules, and optional retractors). It may also require installing a cabling raceway and pulling cables through it.

Prepare the Site

To prepare the site:

1. Decide on the method for cutting a hole in the table (see “Cut the Table” below).
2. If necessary, obtain the correct cut-out template and verify the dimensions (see the template information below).
3. Protect the surface prior to and during cutting so the surface is not damaged.

Cut the Table

CAUTION: Wear safety glasses when operating power equipment. Failure to comply can result in eye injury.

ATTENTION : Portez des lunettes de sécurité lorsque vous utilisez l'équipement électrique. Ne pas respecter cela peut conduire à une blessure à l'oeil.

ATTENTION:

- The opening in the table for the Cable Cubby should be cut only by licensed and bonded craftspeople. Exercise care to prevent scarring or damaging the furniture.
- L'ouverture dans la table pour le Cable Cubby doit être coupée uniquement par un ouvrier détenteur d'une licence. Veillez à ne pas laisser de marques ni à détériorer le mobilier.
- Follow all national and local building and electrical codes that apply to the installation site.
- Respectez tous les codes électriques et du bâtiment, nationaux et locaux, qui s'appliquent au site de l'installation.
- Use the appropriate metal Extron routing template or refer to the surface cutout dimensions before cutting a hole in the furniture or other surface. Pay special attention to the direction the unit will face. The connector access side is underlined (see “CNC Wood Router” below). Extron is not responsible for miscut mounting holes.
- Utilisez le gabarit de détourage métallique approprié ou reportez-vous aux dimensions de découpe de la surface indiquées ci-après avant de découper le meuble ou la surface. Faites particulièrement attention à la direction dans laquelle l'unité sera dirigée. Le côté pour accéder au connecteur est souligné (voir «CNC Wood Router» ci-dessous). Extron décline toute responsabilité en cas d'erreurs de coupe.
- Ensure the table surface is at least 0.50 inch (12.7 mm) thick.
- Assurez vous que la surface de la table est au moins 12,7 mm (0,50 pouce) d'épaisseur.

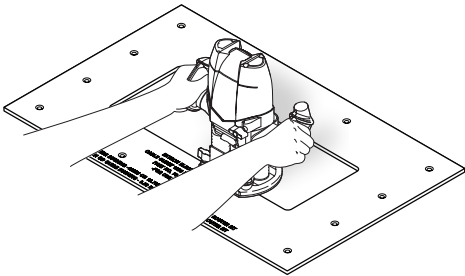
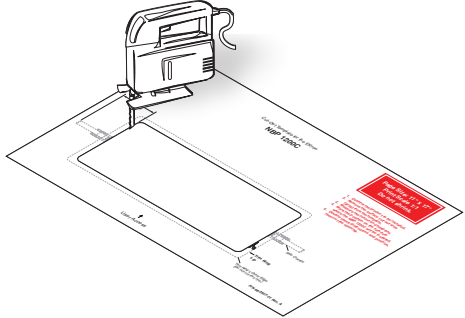
Hand Router and Routing Template	Jigsaw and Paper Cut-out Template	CNC Wood Router
 <p>Visit the NBP 1200C page at www.extron.com for the Cable Cubby 1200/1200C/1202 routing template part number and instructions.</p>	 <p>The cut-out template (the <i>NBP 1200C Cut Out Template</i>) and dimensions are available online on the NBP 1200C page at www.extron.com.</p>	<p>If using a CNC wood router or other precise machinery, use the exact cut-out dimensions:</p> <p>User Access Width 10.00" (254.0 mm)</p> <p>Depth 4.00" (101.6 mm)</p>

NOTE: The metal router guide must be purchased separately. It is reusable and should not be discarded when the installation is complete.

Step 3: Assemble AAP, Pass-through, and Power Modules

A variety of modules allow you to populate the Cable Cubby enclosure with a combination of AAPs, cable pass-through plates, retractors, or power modules. The NBP 1200C accommodates your choice of any two modules, allowing you to customize the device to meet your needs.

Assemble Connectivity Modules

The NBP 1200C ships with a single connectivity bracket that can be used with either the AAP frame plate or the cable grommet plate. Follow the steps below to assemble the connectivity modules of your choice before mounting them into the NBP 1200C.

NOTE: After assembling the modules, proceed to **Step 5: Install Modules and a Retractor Bracket** on page 29.

AAP module

The AAP plate accommodates up to three single-space AAPs. Assembly procedures are shown in the figure below.

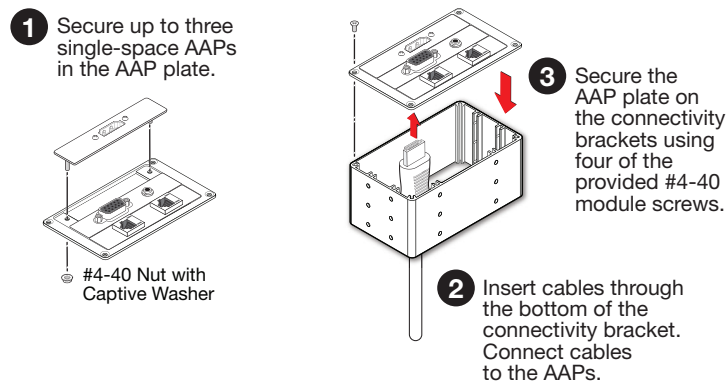

Figure 25. Assembling the AAP Module

Cable pass-through module

The cable pass-through module accommodates up to eight AV cables. Assemble the cable grommet plate, and plug in the module as shown in the figure below.

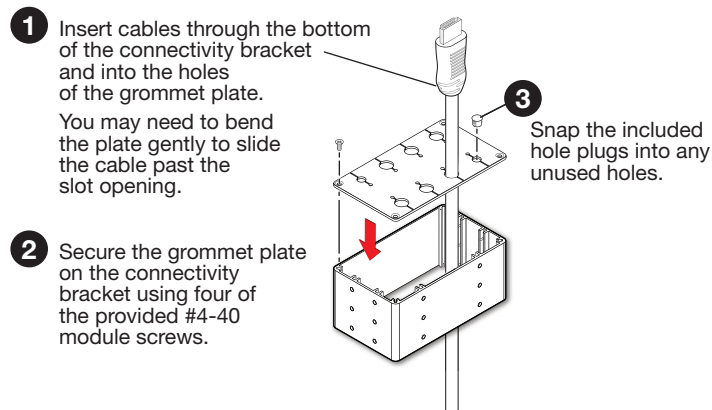
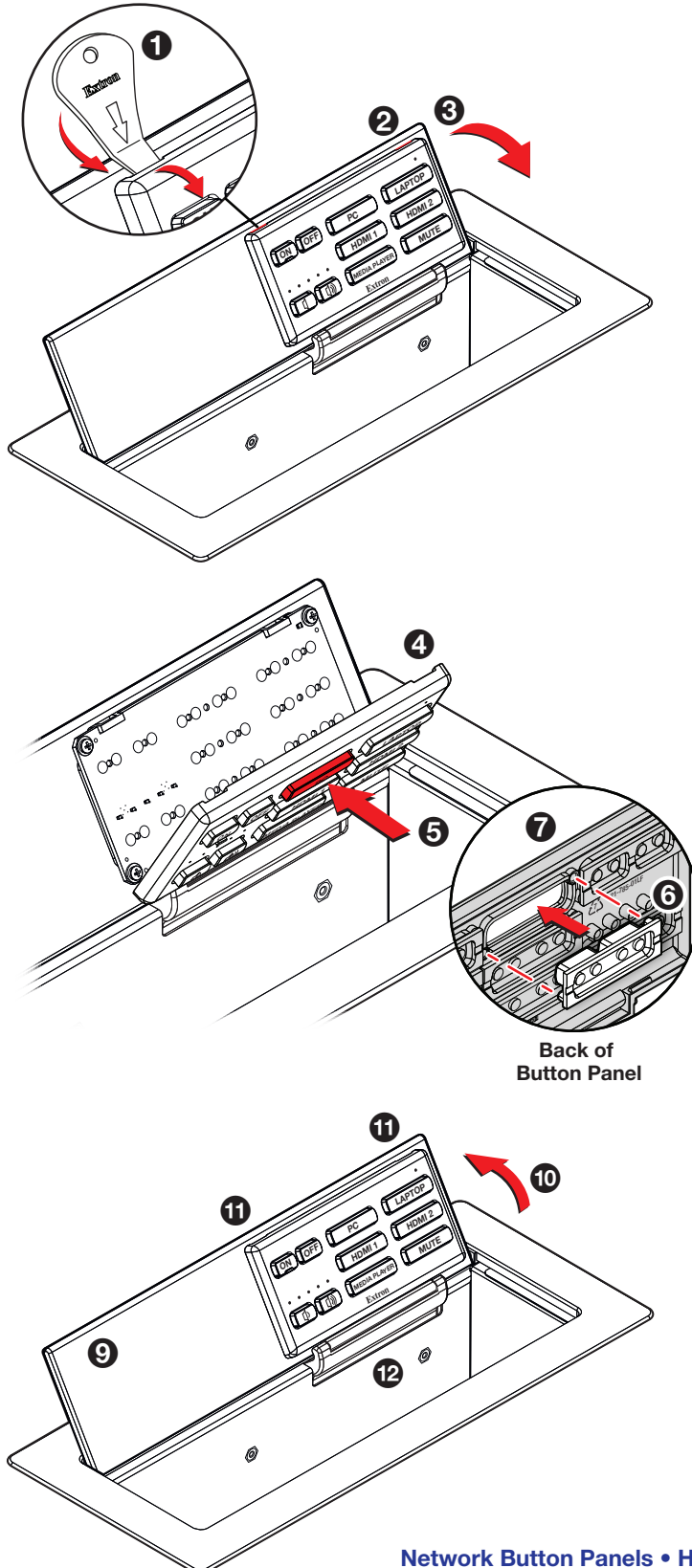

Figure 26. Assembling the Cable Pass-through Module

Step 4: Change Buttons (optional)

If desired, replace one or more buttons using available additional buttons. Optional button kits are available in various languages.

NOTE: A custom button builder tool is available at <https://www.extron.com/article/custombuttonbuilder> where you can order custom-labeled buttons for the NBP.



- 1 Insert the Extron removal tool into one of the removal slots in the top edge of the button panel. Carefully release the corner of the panel.
- 2 Repeat step 1 to release the opposite corner of the panel.
- 3 Tilt the lid forward to prevent the buttons from falling out.

- 4 Pull the top of the button panel forward. The panel is attached to the lid with a hinge that allows access to the buttons without the panel becoming completely detached. You can now return the lid to the fully open position.

- 5 From the front of the panel, press the button until it is free of the panel.

- 6 From the back of the button panel, insert the replacement button into the appropriate slot. Ensure the text is in the correct orientation. Align the two pegs on the button with the holes on the button panel.

- 7 Press the button into the faceplate until the pegs on the button are seated securely in the holes.

- 8 Repeat steps 5-7 for any other buttons that need to be replaced.

- 9 Tilt the lid forward to prevent the buttons from falling out.

- 10 Tilt the lid and the button panel backwards.

- 11 Press the top corners so that they snap back into place, securely attaching the button panel to the lid.

If the corners do not snap back easily, you may need to adjust how the button panel is seated in the hinge attaching it to the lid (12).

Step 5: Install Modules and a Retractor Bracket

Determine where the modules are to be installed in the Cable Cubby enclosure. Any combination of two modules can be installed. The modules can be installed on either side of the enclosure and at various heights.

NOTES:

- Ensure that there is enough room above the modules for the Cable Cubby lid to close completely. This also requires that any retractor brackets be installed as close as possible to the bottom of the enclosure.
- Extron recommends mounting the power module on the left side of the enclosure.
- For any cables that must be connected to modules, feed them up through the table or other furniture before attaching them to each module.
- Use a screwdriver to secure the modules with the screws.

Retractor Bracket

Use the retractor bracket to mount cable retractors in the Cable Cubby enclosure. The retractor bracket accommodates up to three Retractor Series or Retractor Series XL cable retraction modules.

The retractors must be purchased separately. Visit www.extron.com to find available retractor models, retractor filler modules, and optional retractor brackets.

If you require retractors, insert the retractor bracket as shown in figure 27.

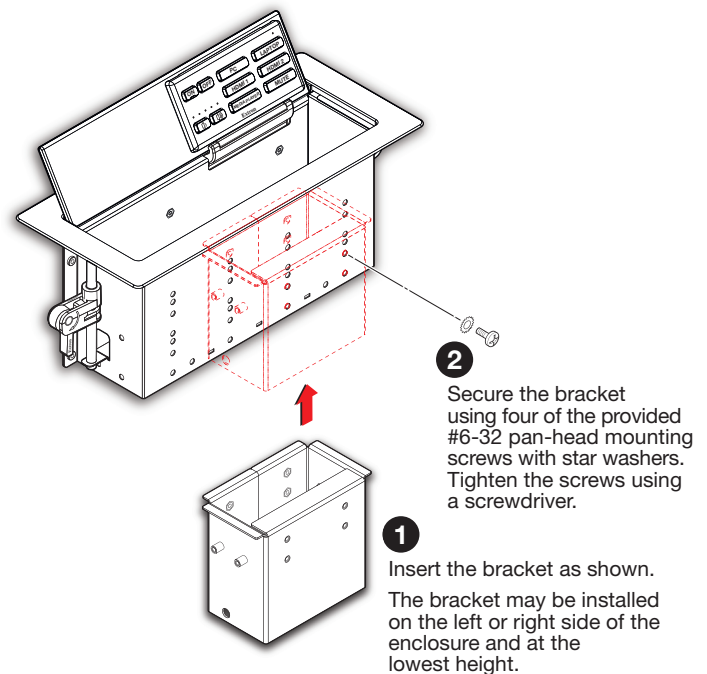

Figure 27. Installing the Retractor Bracket

NOTE: Do not mount the retractors in the retractor bracket until after the Cable Cubby is mounted (see [Step 7: Install Retractors](#) on page 32.)

Install retractor filler modules in any unused retractor mounting spaces.

Install the retractor bracket as close as possible to the bottom of the enclosure to ensure that there is sufficient clearance at the top of the retractor inside the CableCubby. If the bracket is installed too high in the Cable Cubby, the lid will not close due to contact with the retractor module.

For full details on how to install a Retractor, see the *Retractor Series Installation Guide*, available on the Retractor Series or Retractor Series XL product page at www.extron.com.

An optional Cable Cubby Retractor Bracket Kit – Double allows two cable retractors to be mounted at the outer edges of the enclosure with one of the other modules mounted centrally. These brackets must be purchased separately and they are sold in pairs.

AAP Module, Cable Pass-through Module, and Power Module

Insert the modules into the Cable Cubby as shown in figure 28.

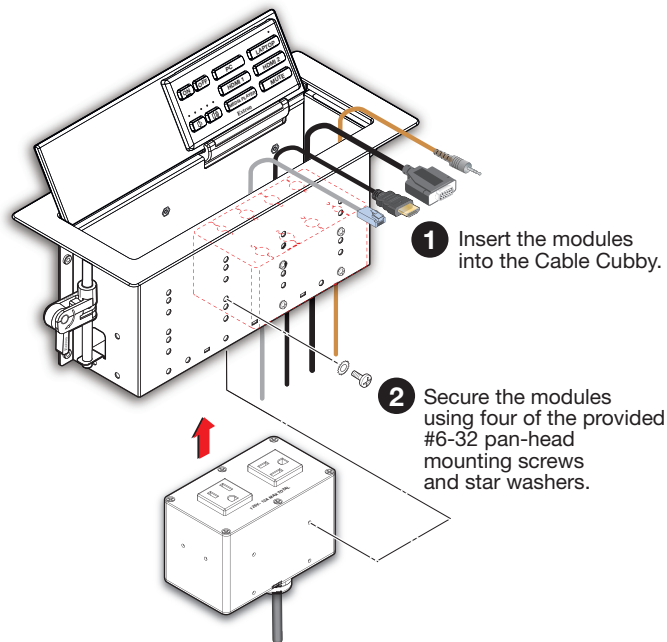

Figure 28. Installing the Connectivity and Power Modules

AC power and AC+USB power modules are available for US, Europe, and other major world markets. They must be purchased separately (see www.extron.com). If you install a power module, you must ground the unit using the provided #6-32 star washers and mounting screws.

- Most AC power modules provide two unswitched AC outlets.
- The AC+USB power modules provide one or two AC outlets and two USB power outlets.

WARNING: Risk of Electric Shock. To ensure proper electrical grounding, use the provided #6-32 mounting screws with the star washers.

AVERTISSEMENT : Risque de choc électrique. Afin d'assurer une mise à la terre correcte, utilisez les fixations de mise à la terre #6-32 et les rondelles en étoile fournies.

Step 6: Mount the NBP 1200C to the Table

Insert the NBP 1200C Enclosure into the Table

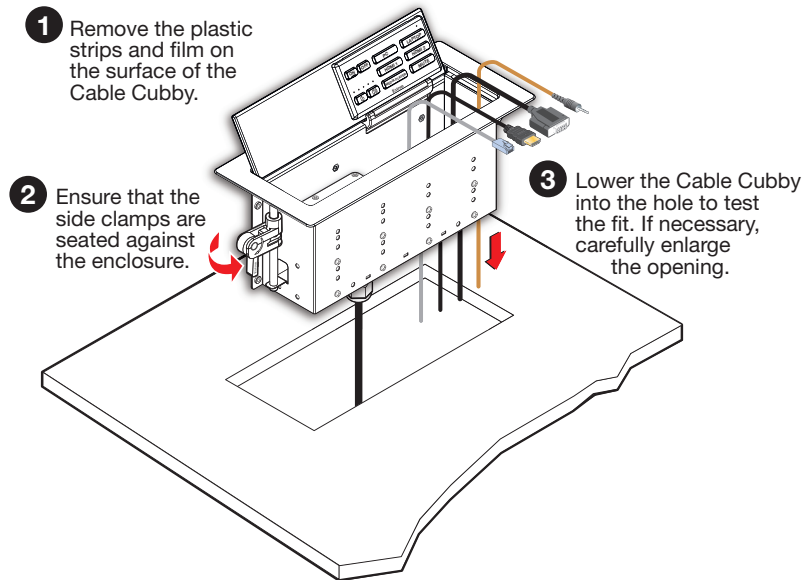

CAUTION: The flanged edges of the top of the surface enclosure are sharp. These edges are also soft and may be easily nicked or bent. Exercise caution when handling the enclosure to prevent personal injury or damage to the enclosure.

ATTENTION : Les extrémités à brides du haut de la surface du boîtier sont aiguisées. Ces extrémités sont aussi lisses et peuvent facilement être coupées ou pliées. Soyez prudents lorsque vous manipulez le boîtier afin d'éviter de l'endommager ou de vous blesser.

Figure 29. Inserting the NBP 1200C Enclosure into the Table

Under the Table, Adjust the Side Clamps on the Enclosure

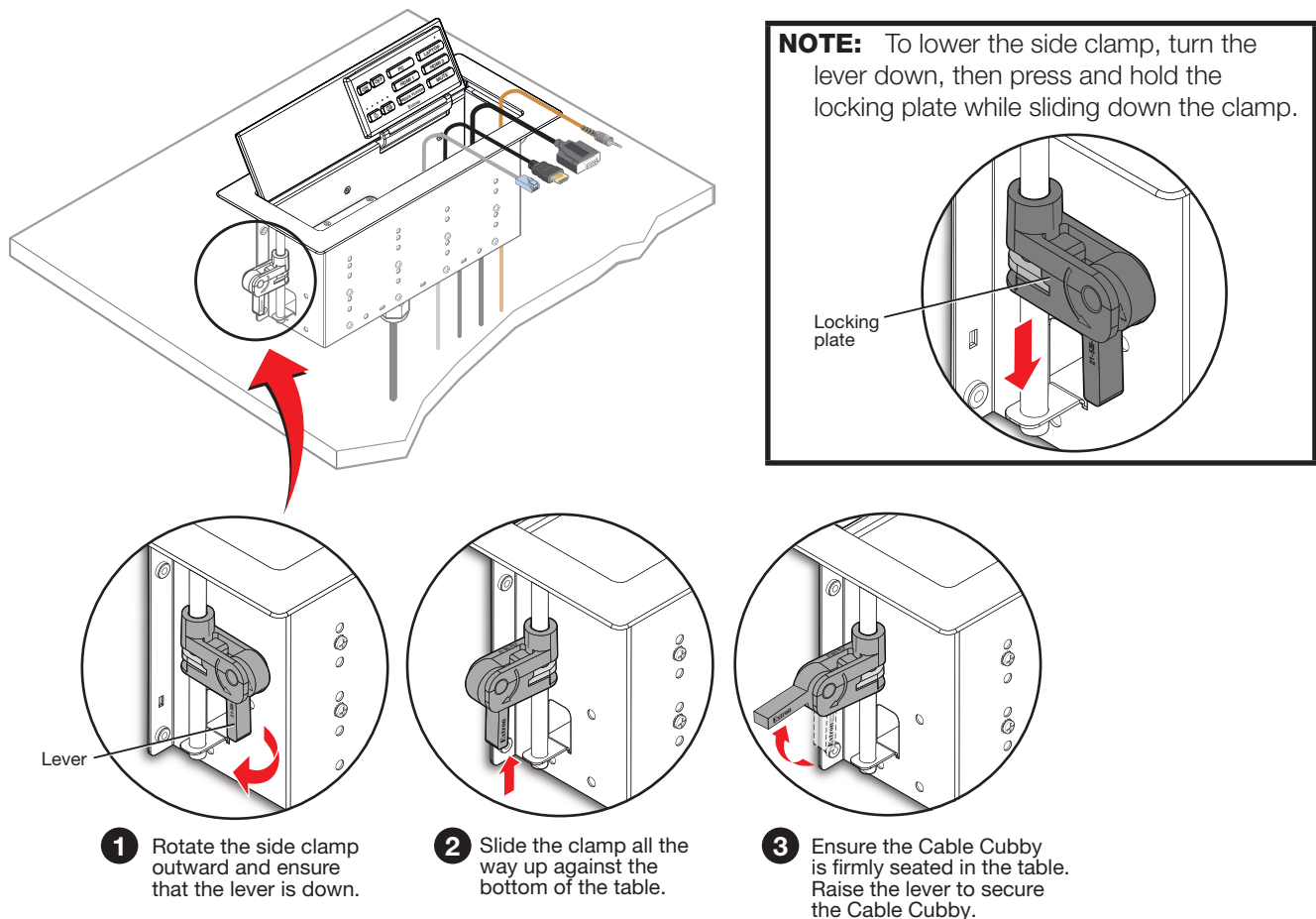

Figure 30. Securing the Cable Cubby Enclosure

Step 7: Install Retractors

Retractors can be installed in a vertical, angular, or horizontal orientation. No adjustment of the enclosure screws is needed if the retractors are mounted vertically. To mount at an angle or horizontally, adjust the enclosure screws as shown below. When the retractors are mounted horizontally, the retractor mechanism must be secured to the underside of the table (see the *Cable Retractor Setup Guide*, available at www.extron.com).

To secure the retractors in the retractor bracket, follow the instructions in figure 31.

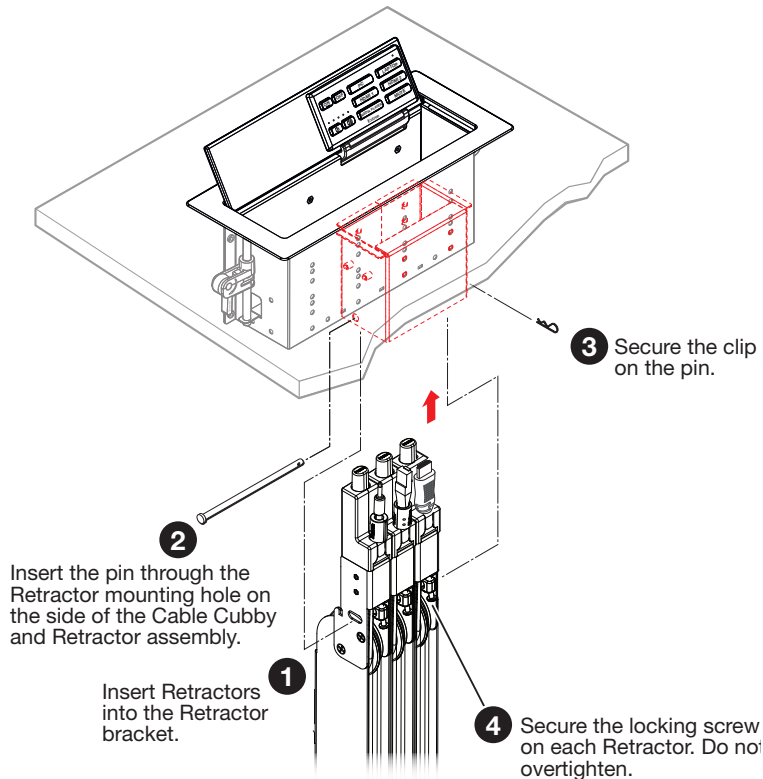
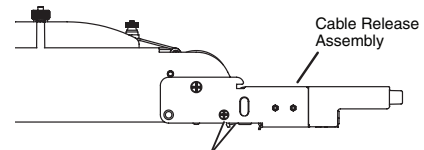

Figure 31. Installing Retractors

Horizontal Mounting



Remove two enclosure screws (one on each side) from this position. Then mount the Retractors as shown at left.

See the *Cable Retractor Setup Guide* for additional steps.

Angular Mounting

Remove the two enclosure screws, as shown above, and then follow this step:

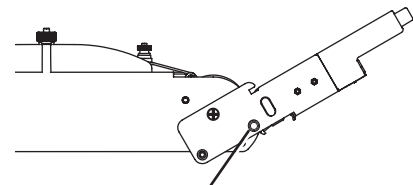

Move the cable release assembly upward until the angular mounting hole is visible. Reinstall the enclosure screws in this hole (both sides).

Step 8: Install Cables in the Cable Cubby

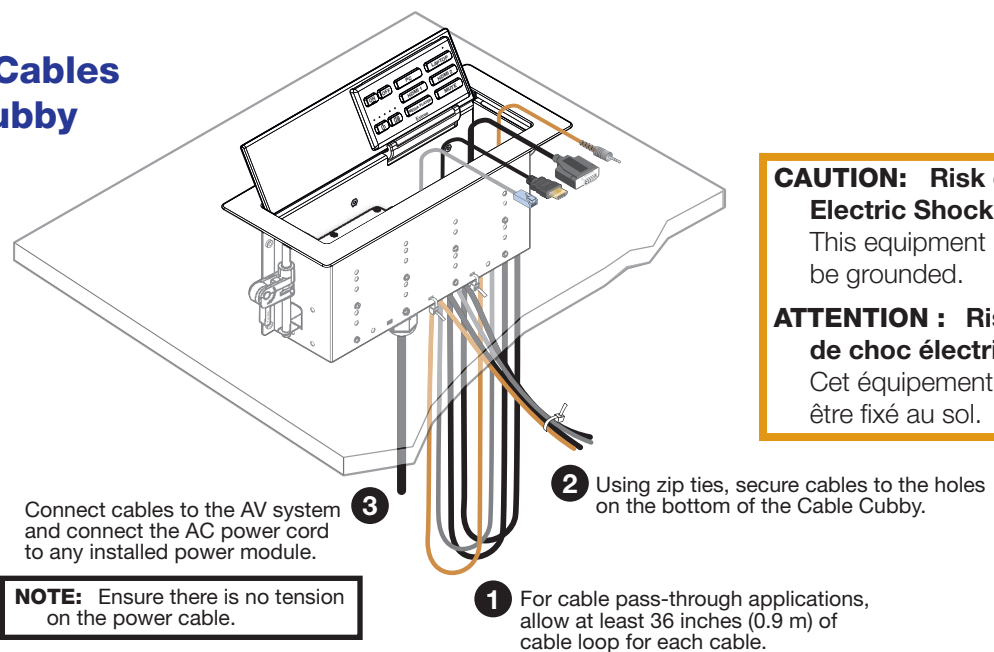

NOTE: Ensure there is no tension on the power cable.

CAUTION: Risk of Electric Shock.
This equipment must be grounded.

ATTENTION : Risque de choc électrique.
Cet équipement doit être fixé au sol.

Figure 32. Route and Connect AV Cables

Step 9: Cable the NBP 1200C and Other Devices in the System

Bottom Panel Features and Cabling (NBP 1200C)

1. Run a network cable to the NBP 1200C.
2. Connect the NBP to the network via the LAN/PoE port on the bottom panel of the NBP 1200C (as shown in figure 33). Port details are shown in figure 34.

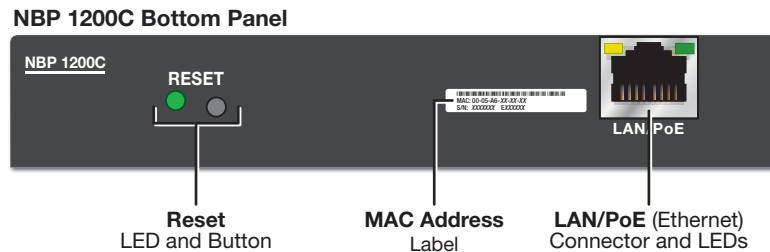

Figure 33. NBP 1200C Bottom Panel Features

Details of LAN/PoE port connection, LED behavior, protocol, addresses, and credentials are shown in figure 34.

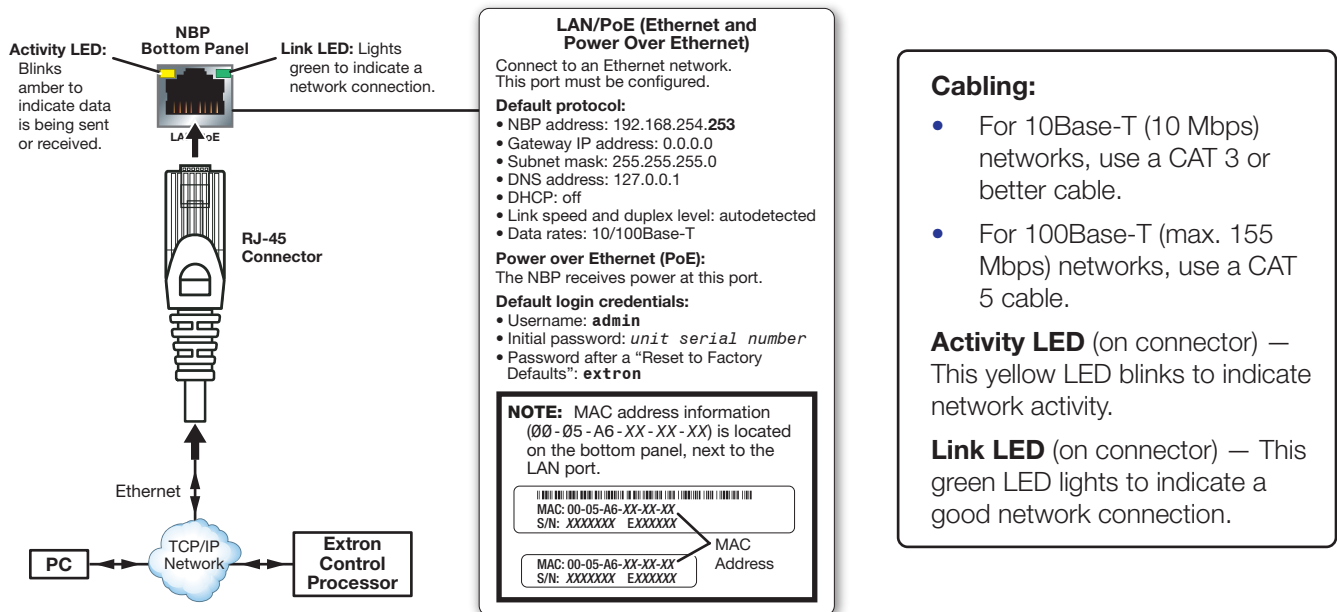

Figure 34. NBP 1200C LAN/PoE Port Details

IMPORTANT NOTES:

- The factory configured password for this device has been set to the device serial number. Passwords are case sensitive. Performing a Reset to Factory Defaults (see [Resetting the Unit](#) on page 42) sets the password to **extron**.
- DHCP is off by default.

ATTENTION:

- Power over Ethernet (PoE) is intended for indoor use only. It is to be connected only to networks or circuits that are not routed to the outside plant or building.
- L'alimentation via Ethernet (PoE) est destinée à une utilisation en intérieur uniquement. Elle doit être connectée seulement à des réseaux ou des circuits qui ne sont pas routés au réseau ou au bâtiment extérieur.
- If not provided with a power supply, this product is intended to be supplied by a UL Listed power source marked "Class 2" or "LPS" and rated output 48 VDC (PoE), minimum 0.35 A, or 56 VDC (PoE), minimum 0.8 A.
- Si le produit n'est pas fourni avec une source d'alimentation, il doit être alimenté par une source d'alimentation certifiée UL de classe 2 ou LPS, avec une tension nominale 48 Vcc (PoE), 0,35 A minimum, ou 56 VDC (PoE), 0,8 A minimum.
- The installation must always be in accordance with the applicable provisions of National Electrical Code ANSI/NFPA 70, article 725 and the Canadian Electrical Code part 1, section 16. The power supply shall not be permanently fixed to building structure or similar structure.
- Cette installation doit toujours être conforme aux dispositions applicables du Code américain de l'électricité (National Electrical Code) ANSI/NFPA 70, article 725, et du Code canadien de l'électricité, partie 1, section 16. La source d'alimentation ne devra pas être fixée de façon permanente à une structure de bâtiment ou à une structure similaire.
- The Network Button Panels are intended to be used with Extron Electronics UL Listed products only.
- L'utilisation des claviers de commande réseau est prévue uniquement avec des produits certifiés UL Extron Electronics.

MAC address — This is the unique user hardware ID number (Media Access Control [MAC] address) of the unit (for example, 00-05-A6-05-1C-A0). You may need this address during configuration. The label is on the bottom panel of the NBP 1200C (as shown in [figure 33](#) on page 33).

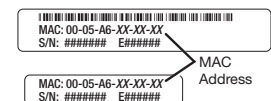

3. Cable devices to the control processor or HCR receiver (see the user guide for the appropriate device), and connect the control processor or HCR receiver to the same network as the NBP.
4. Connect power cords and power on the control processor or receiver and other devices.

Step 10: Set up the NBP 1200C for Network Communication

1. Connect the NBP button panel and the PC to be used for setup to the same Ethernet subnetwork.
2. Start Toolbelt and use it to set DHCP on or to set the IP address, subnet, gateway IP address, DHCP status, and related settings. Network setup is essential prior to configuration.

Use the flowchart at right as a guide to setting up the unit for network use.

NOTES:

- If using a host name instead of an IP address the user must enter a qualified host name (*Username.HostName.Domain*). For example: `somename.somedomain.com`.
- If using 802.1X security, see the *Extron 802.1X Technology Reference Guide* and the *Toolbelt Help* file for additional details on system setup.

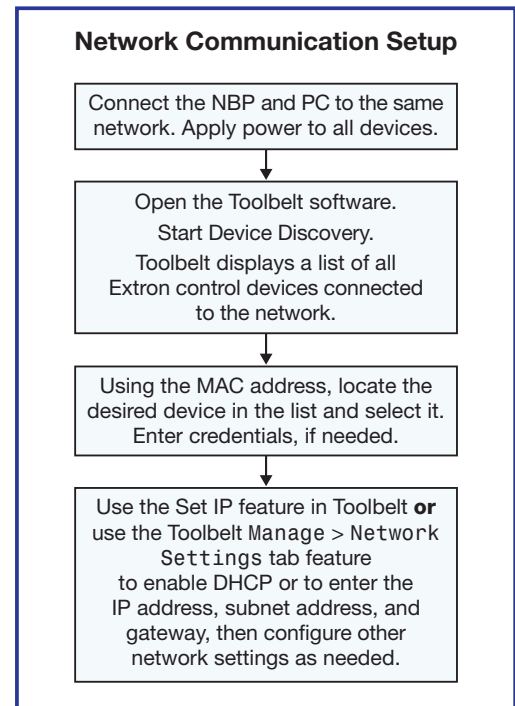

Figure 35. Network Setup

Step 11: Configure the System

Use Global Configurator (GC Plus or GC Professional) to configure the IPCP Pro control processor, IPL Pro control processor, or HCR receiver. Alternatively, use Global Scripter to program the IPCP Pro or IPL Pro control processor. That configuration sets the control and monitoring behavior for all the AV devices and control accessories (such as the NBP button panels) in the system. An outline of the main configuration and programming steps is included in the user guide for the control device.

NOTE: See the *Toolbelt Help File*, *Global Configurator Help File*, and *Global Scripter Help File* as needed for step-by-step instructions and detailed information. The help file for GC includes an introduction to the software, and how to start a project and configuration.

When configuration or programming is completed, save the project or program script, then build and upload the system configuration to the control processor or receiver.

Step 12: Test and Troubleshoot

1. Test the system (see the *IPCP Pro Series User Guide*, *IPL Pro Series User Guide*, or *HC 400 Series User Guide* for an outline of the system testing and troubleshooting procedure).
2. Make adjustments to wiring or configuration as needed.

Operation

This section of the guide covers the following topics:

- **Front Panel Features (All Models) and NBP 1200C Bottom Panel Features** — Locations and descriptions of items on the front panel and the bottom panel features of the NBP 1200C
- **Reset Features and Resetting the Unit** — Locations of the Reset button and LED and information about the available reset modes and how to reset the NBP button panel

Front Panel Features (All Models) and NBP 1200C Bottom Panel Features

Some features and indications are described in the **Rear and Side Panel Features and Cabling (Decorator-style and US Gang Models)** section starting on page 16 and **Bottom Panel Features and Cabling (NBP 1200C)** on page 33 with a description of the rear or bottom panel LAN port. The rest are detailed in this section.

NOTE: The system and NBPs must be configured in order to function. See **Software-based Configuration and Control** starting on page 44, and see the *Global Configurator Help File*, *Toolbelt Help File*, and *Global Scripter Help File* for information about the software, and step by step instructions for basic setup.

All the function, power, and volume buttons or knob must be configured or programmed to carry out their functions. The buttons are backlit by LEDs.

- Buttons that are configured or programmed but are inactive are dimly lit.
- Buttons that are not configured are dimly lit.
- The NBP decorator models can buzz or chirp each time a button is pressed.

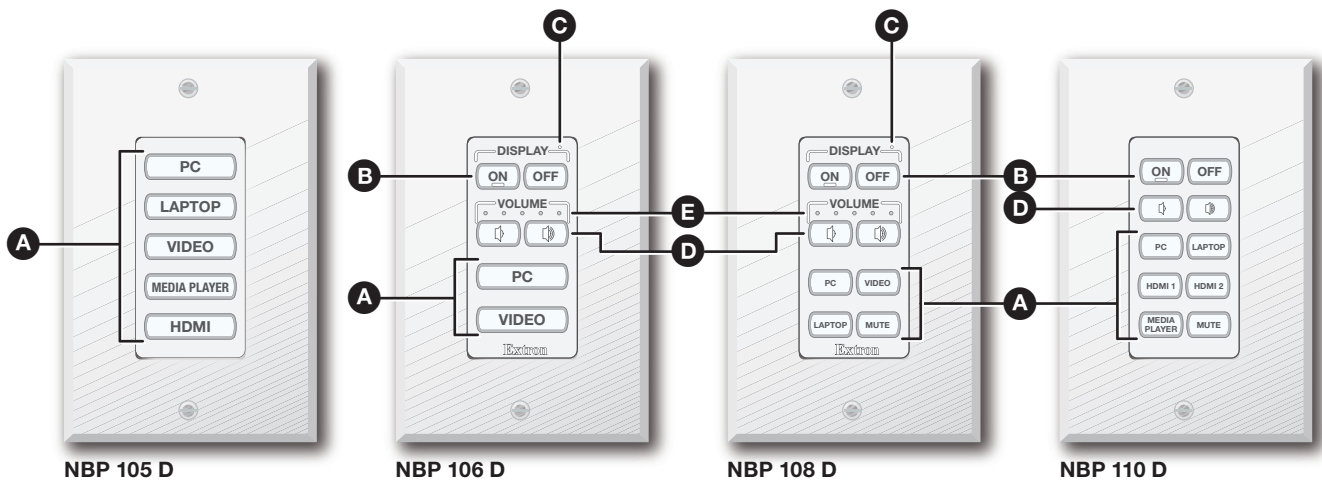

Figure 36. Decorator-style NBP Front Panels With Wallplates

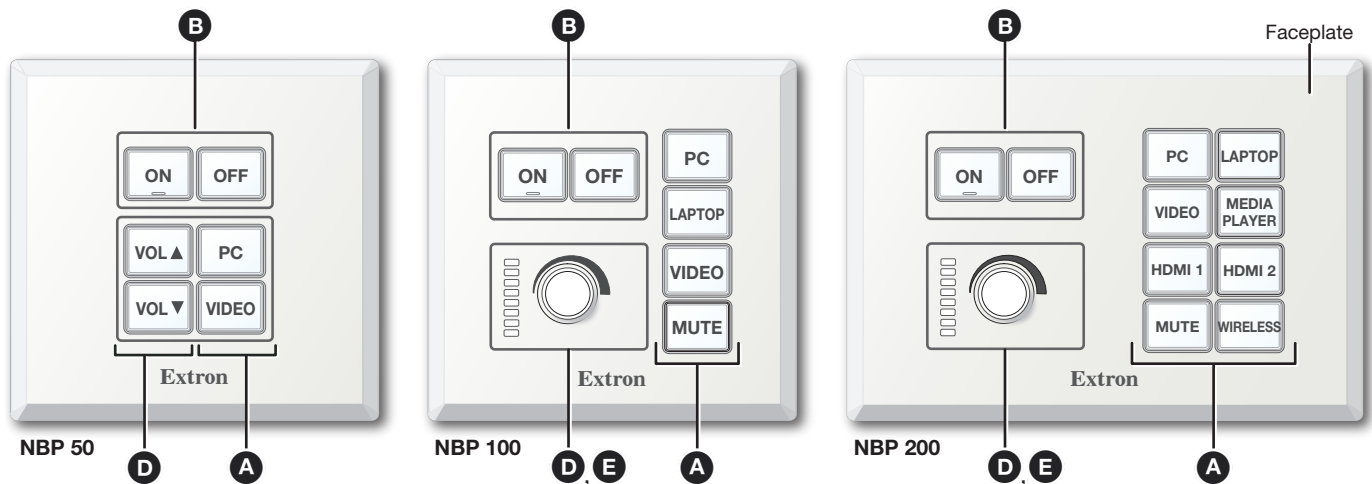

Figure 37. US Gang NBP Front Panels With Faceplates

- A Function buttons** — Configure these buttons to light and function as desired.
- B Power buttons** — These buttons (present on certain models only) are usually used to control the power to the display device. The **On** button has a nub that can be felt with finger tips.
- C Communications LED** (NBP 106 D, 108 D, 1200C) — This LED indicates the configuration and connection status of the NBP.
 - **Unlit** — Normal operation (the NBP is configured and connected to an IPCP Pro control processor).
 - **Blinking red** — The NBP has been configured but is not connected to an IPCP Pro control processor.
 - **Lit steadily** — The NBP has not been configured.
- D Volume buttons** (on certain decorator-style models, and NBP 1200C) or **volume knob** (on NBP 100 and NBP 200) — Configure **Volume** buttons or the **volume knob** to increment or decrement audio volume.

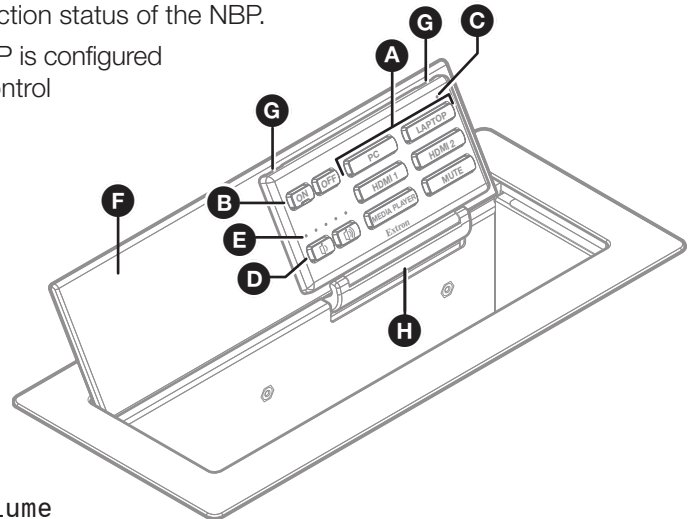

Figure 38. NBP 1200C Front Panel

- E Volume LEDs** (see [figure 36](#), [figure 37](#), and [figure 38](#) on page 37 — Volume LEDs (present only on models with **Volume** buttons or a **volume knob**) light to act as a meter to indicate the volume level.
- F Cable Cubby lid** (NBP 1200C, see [figure 38](#) on the previous page) — The lid tilts back to 130°. Friction washers ensure the lid holds any angle set by the user. A switch in the hinge activates the buttons when the lid is fully open and deactivates them when the lid is closed to prevent accidental button presses.
- G Button panel removal slots** (NBP 1200C, see [figure 38](#)) — Use the Extron removal tool in these slots to release the top of the panel when replacing buttons.
- H Button panel hinge** (NBP 1200C, see [figure 38](#)) — Holds the bottom of the panel in place, allowing the panel to tilt forward when replacing buttons.

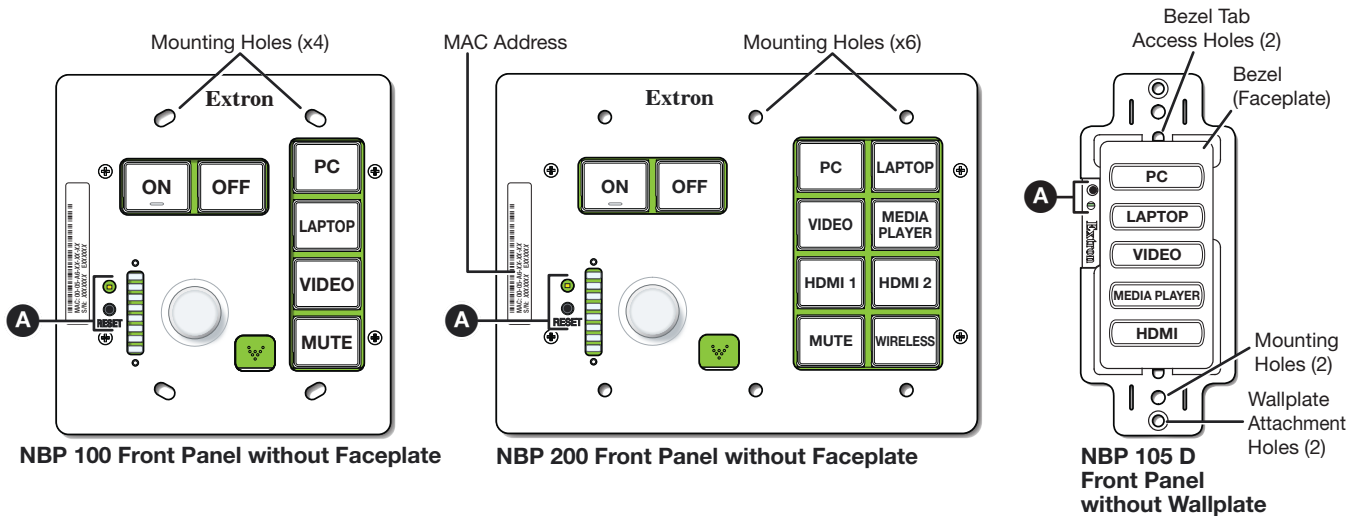

Figure 39. NBP Front Panels Without Faceplates or Wallplates



Figure 40. NBP 1200C Bottom Panel Features

- A Reset button and LED** (see [figure 39](#) and [figure 40](#), **A** above)— Pressing this recessed button (present on all models) causes various product settings to be reset to the factory defaults (see [Reset Features and Resetting the Unit](#) on page 42). The LED is normally off except during resets and immediately after boot-up.

Wallplates and Bezels

Each decorator-style NBP is shipped with a white bezel and white wallplate and also a black bezel and black wallplate.

Each US gang model is shipped with a white faceplate and a black faceplate. Each NBP 100 or NBP 200 is also shipped with a white knob and a black knob.

See **Step 3: Change Buttons, Button Labels, a Bezel, or Wallplate (optional)** on page 12 for instructions on how to change the bezel, wallplate, faceplate, buttons, or button labels for wall-mountable models. See **Step 4: Change Buttons (optional)** on page 28 for instructions on changing buttons on an NBP 1200C.

Buzzer (Decorator-style Models and NBP 1200C)

The NBP decorator-style models and the NBP 1200C have a buzzer located on a circuit board within the unit. The behavior of the buzzer can be configured using Global Configurator or programmed with Global Scripter to be globally disabled or to beep as desired when a button is pressed.

Buttons



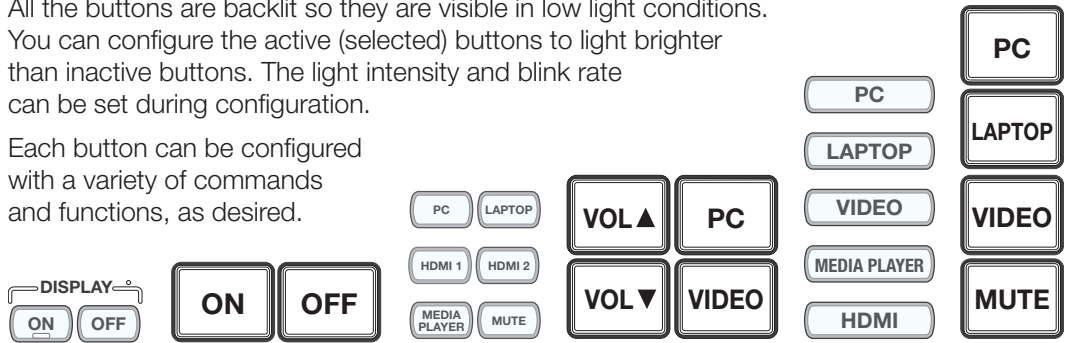

All the buttons are backlit so they are visible in low light conditions. You can configure the active (selected) buttons to light brighter than inactive buttons. The light intensity and blink rate can be set during configuration.

Each button can be configured with a variety of commands and functions, as desired.



Volume Controls and LEDs

You must configure these buttons (NBP decorator-style models, NBP 1200C) or knob (NBP 100 or NBP 200). They can be used for any function and behavior and to control any device. However, the most common configuration is as follows:

- On the decorator-style models and NBP 1200C:
Press the **increase volume** button  to increase the audio volume.
Press the **decrease volume** button  to decrease volume.
- On the NBP 50:
Press the **increase volume** button  to increase the audio volume.
Press the **decrease volume** button  to decrease volume.
- On the NBP 100 and 200 models, rotate the **volume knob** clockwise to increase the audio volume, counterclockwise to decrease volume.
- On decorator-style models and NBP 1200C, the **Mute** button can be configured to turn audio output off or on.



The Volume LEDs directly above the buttons (NBP 106 D, NBP 108 D, NBP 1200C) or to the left of the knob (NBP 100, NBP 200) can be configured as follows:

- Blink to indicate increases or decreases or to show volume level status (see [Volume control options](#) below for additional details).
- Light in patterns such as upward or downward sweeps to indicate increases or decreases for increment or decrement adjustments, or to indicate a volume level range for range-based adjustments (see “Volume control options” below for additional details)

For all models, when audio mute is active, mute would typically be indicated by a slowly blinking LED (shown in the diagrams at right), no matter which port is used for audio control or what mode (range-based) is being used. When the audio is unmuted, the volume returns to the previously used level.

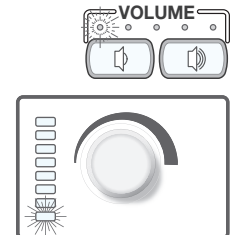

Volume control options

Global Configurator software and Global Scriptor programming let you configure the **volume** buttons (decorator-style models, NBP 50, NBP 1200C) and **volume knob** (NBP 100, NBP 200) to control audio volume using serial or IR control commands together with a COM or IR port on the IPCP Pro or IPL Pro control processor or HCR receiver.

You can specify incremental adjustments or range-based adjustments (via device driver only). See the *Global Configurator Plus and Global Configurator Professional Help File* or the *Global Scriptor Help File* for details on these types of volume adjustments and on how to configure the **volume** LEDs (for the desired lighting behavior).

Range-based volume adjustment

If the system is configured for use with some projectors, the most common way to configure the LEDs on the NBPs is to indicate **volume ranges** (with steadily lit LEDs), as shown in the following diagrams.

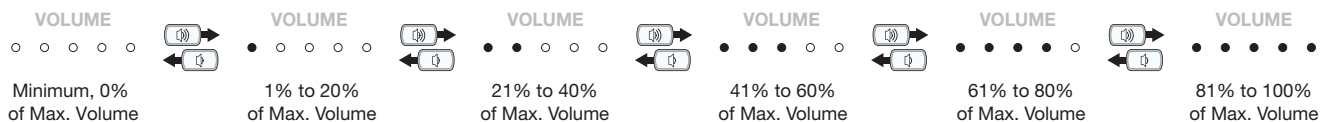

Figure 41. Range-based Volume Adjustment LED Behavior, NBP 105 D, NBP 106 D

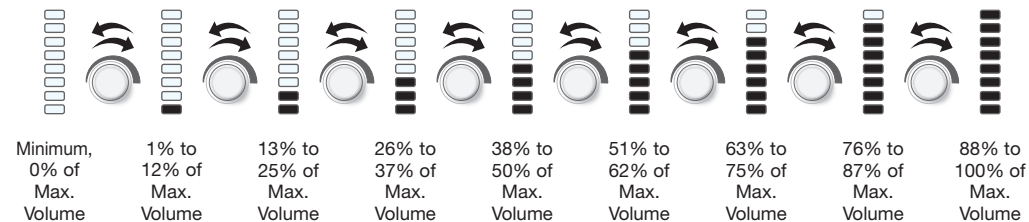

Figure 42. Range-based Volume Adjustment LED Behavior, NBP 100, NBP 200

NOTE: Volume LEDs light based on the percentage of the user-set minimum-maximum range.

Increment/decrement volume adjustment

If the system is configured for **increment/decrement** volume adjustment, typically you would configure the volume LEDs to be off except during adjustment. In the most common configuration, when the volume is adjusted, the LEDs light briefly in a scrolling pattern to the right or top (increment) or to the left or down (decrement), as shown in the following examples.

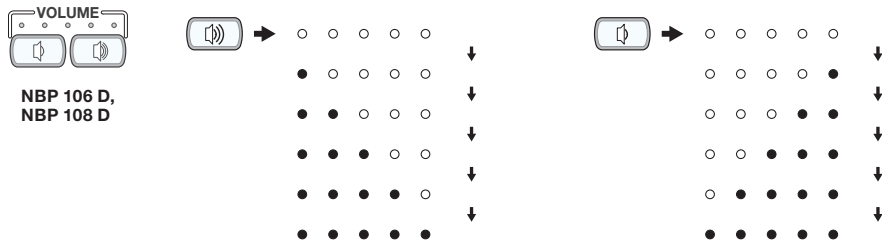

Figure 43. Volume LED Increment/Decrement Behavior for NBP 105 D, NBP 106 D, NBP 1200C

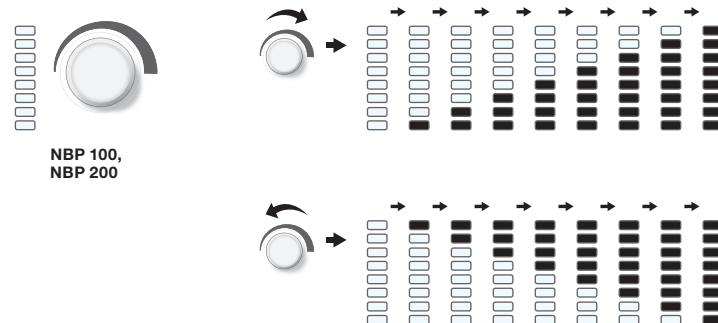

Figure 44. Volume LED Increment/Decrement Behavior for NBP 100, NBP 200

Reset Features and Resetting the Unit

Locating the Reset Button and LED

The **Reset** button and LED (shown at right) are located on the front panel of each decorator-style or US gang series unit, behind the wallplate or faceplate (see [figure 39](#), **F**, on page 38) or on the bottom panel of the NBP 1200C (see [figure 40](#), **F**, on page 38).



Resetting the Unit

There are several reset modes that are available by pressing the **Reset** button. The **Reset** button is recessed, so use an Extron Tweezer, a pointed stylus, or a ballpoint pen to access it. See the reset modes table on the following page for a summary of the modes.

ATTENTION:

- Review the reset modes carefully. Using the wrong reset mode may result in unintended loss of flash memory programming, port reassignment, or a unit reboot.
- Analysez minutieusement les différents modes de réinitialisation. Appliquer le mauvais mode de réinitialisation peut causer une perte inattendue de la programmation de la mémoire flash, une reconfiguration des ports ou une réinitialisation de l'unité.

NOTE: If you press and hold the **Reset** button continuously, the LED blinks every 3 seconds, and the unit enters a different mode, from the Reset All IP Settings mode through the Reset to Factory Defaults mode. For Reset to Factory Defaults mode the LED blinks three times, the third blink indicating the last mode. The modes are separate functions, not a continuation from one mode to the next.

NBP Series Reset Mode Summary

Mode	Use This Mode to...	Activation	Result
Use Factory Firmware	Temporarily boot up the unit with factory-installed firmware for a single power cycle in the event that a firmware update has failed or if incompatibility issues arise with user-loaded firmware	<p>To start the Use Factory Firmware reset mode and replace firmware:</p> <ol style="list-style-type: none"> On the NBP, press and hold the recessed Reset button while applying power to the unit. Keep holding the button down until the Reset LED blinks twice, then release the button. The LED blinks slowly during bootup. The unit enters factory firmware mode. Upload new firmware to the unit as desired (see Updating the Firmware on page 54 for details). <div style="border: 1px solid black; padding: 5px; margin-top: 10px;"> <p>NOTE: Do not continue to operate the NBP button panel using the factory firmware version. If you want to use the factory default firmware version, you must upload that version again (see the <i>Toolbelt Help File</i> or <i>Global Configurator Help File</i> for firmware upload instructions).</p> </div>	<p>The button panel reverts to the factory default firmware. Event scripting does not start if the unit is powered on in this mode. All user files and settings such as button configurations, adjustments, and IP settings are maintained.</p> <div style="border: 1px solid black; padding: 5px; margin-top: 10px;"> <p>NOTE: To return the unit to the firmware version that was running prior to the reset, cycle power to the unit.</p> </div>
Toggle DHCP Client	Enable or disable the DHCP client	<p>To enable or disable the DHCP client for the LAN port:</p> <ol style="list-style-type: none"> Press the Reset button five times (consecutively). Release the button. Do not press the button within 3 seconds following the fifth press. <div style="border: 1px solid black; padding: 5px; margin-top: 10px;"> <p>NOTES:</p> <ul style="list-style-type: none"> By default DHCP is off and the unit uses a static IP address. When you disable DHCP, the unit reverts to using the previously-set static IP address. </div>	<ul style="list-style-type: none"> The Reset LED blinks 6 times if the DHCP client is enabled. The Reset LED blinks 3 times if the DHCP client is disabled.
Reset All IP Settings	Reset IP settings and port maps to factory defaults without affecting user-loaded files	<p>To reset all IP settings:</p> <ol style="list-style-type: none"> Press and hold the Reset button for about 6 seconds until the Reset LED blinks twice (once at 3 seconds, again at 6 seconds). Release and press the Reset button momentarily (for <1 second) within 1 second*. <p>*Nothing happens if the momentary press does not occur within 1 second.</p> <div style="border: 1px solid black; padding: 5px; margin-top: 10px;"> <p>NOTE: This reset also turns DHCP off.</p> </div>	<p>Reset All IP Settings mode:</p> <ul style="list-style-type: none"> Sets the IP address back to factory default (192.168.254.253) Sets the subnet back to factory default (255.255.255.0) Sets the default gateway address to the factory default (0.0.0.0) Sets domain and host names to factory default Turns DHCP off Disables 802.1X authentication.
Reset to Factory Defaults	Start over with configuration and uploading	<p>To reset the unit to all factory default settings:</p> <ol style="list-style-type: none"> Hold down the Reset button for about 9 seconds until the Reset LED blinks three times (once at 3 seconds, again at 6 seconds, again at 9 seconds). Release and press the Reset button momentarily (for <1 second) within 1 second*. <p>*Nothing happens if the momentary press does not occur within 1 second.</p>	<p>Reset to Factory Defaults mode performs a complete reset to factory defaults (except the firmware).</p> <ul style="list-style-type: none"> Does everything Reset All IP Settings mode does Removes (clears) all user-loaded files and configurations from the NBP Clears driver-port associations (Ethernet) and port configurations

NOTES:

- After performing a Reset All IP Settings or Reset to Factory Defaults reset, use Toolbelt to set the IP address again for use on your network.
- The factory configured password for this device has been set to the device serial number. Passwords are case sensitive. Performing a Reset to Factory Defaults sets the password to **extron**.

Software-Based Configuration and Control

This section of the guide is divided into the following topics:

- [Configuration and Control: an Overview](#)
- [Basic Setup Steps: a Guide to this Section and Other Resources](#)
- [Downloading the Software and Getting Started](#)
- [Troubleshooting](#)

Configuration and Control: an Overview

An NBP and the control processor or collaboration system receiver with which it works must be configured before use in order to recognize and accept commands and pass them on to the controlled devices. They can be configured and controlled via a host computer attached to the same network (see [LAN \(Ethernet\) and PoE connector and LEDs](#) on page 16 and [Bottom Panel Features and Cabling \(NBP 1200C\)](#) on page 33 for details about the LAN port and cabling to connect the NBP button panel to the network).

- Configure the NBP and the control processor or collaboration receiver by using the Global Configurator software (GC Professional or GC Plus), or program the control processor or receiver using Global Scripter. See the Extron [website](#) for full system hardware and software requirements for GC.
- The default web pages embedded within each device provide a means to view general hardware information, network settings, and, if configured, project information. You cannot configure these devices via the embedded web pages.

NOTE: See the diagram within [LAN \(Ethernet\) and PoE connector and LEDs](#) and [Bottom Panel Features and Cabling \(NBP 1200C\)](#) for the default login credentials for the NBP internal web pages.

Basic Setup Steps: a Guide to this Section and Other Resources

NOTE: GC projects can be created offline and uploaded to the hardware at a later date.

Follow the steps in [Hardware Features and Installation – Wall-mountable Models](#) on page 7 or in [Hardware Features and Installation – NBP 1200C](#) on page 22. The overall process for setting up a button panel and system is as follows:

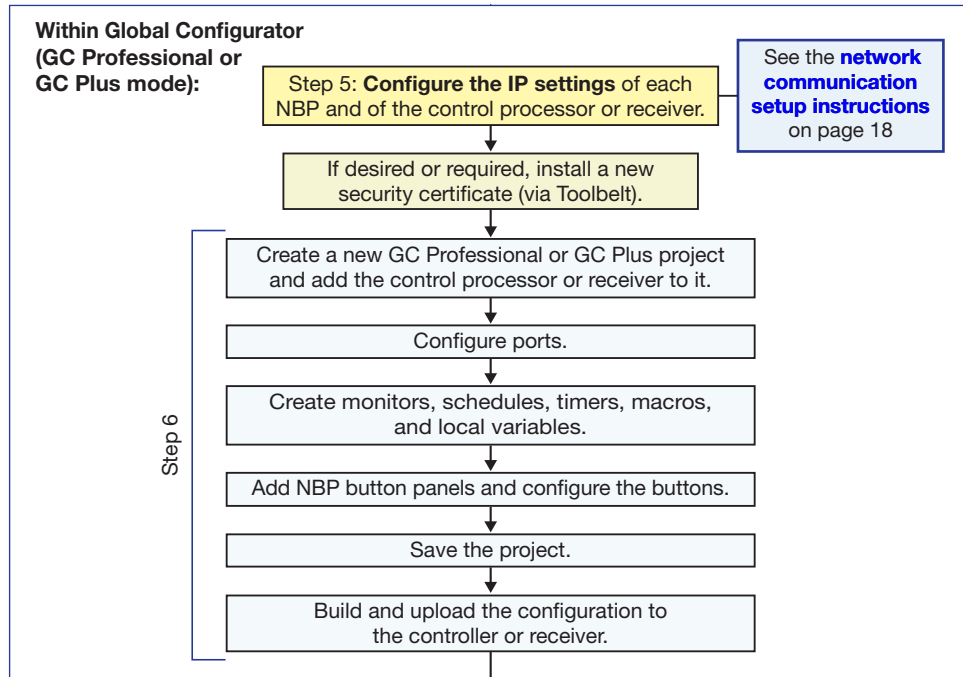

Figure 45. Overall Configuration Steps

Downloading the Software and Getting Started

Software updates and a large variety of device drivers can be downloaded from the **Download** page on the Extron website (<http://www.extron.com/download/index.aspx>). When you locate the desired software or driver package, follow the on-screen directions to download and install it.

Locating Software, Firmware, and Driver Files on the Extron Website

There are three main ways to find software, firmware, and device drivers within www.extron.com:

- Via links from the web page for the specific product
- Via the **Download** page (click on the **Download** tab at the top of any page within the Extron website.)
- Via links from search results

NOTE: For some software you have the option to click the **Download** button to begin downloading the software file. For other software there is a link for contacting an Extron support representative who can provide you access to the latest version.

To obtain Extron control product software, you must have an Extron Insider account and contact an Extron support representative. Extron provides training to our customers on how to use the software. For Global Configurator Professional, you must first attend Extron training, pass a proficiency test, and achieve Extron Control Professional Certification before being able to access all the features of that program.

Via links from the web page for the specific product

1. Navigate to the web page for the specific product model by performing one of the following:
 - Typing the model name into the search field in the upper right of any Extron web page and clicking the **magnifying glass** icon
or
 - Selecting the model name from the **Product Shortcuts** drop-down list in the upper left of the Extron home page or **Products** page.
2. Click the **Downloads** tab in the middle of the product page. A list of available software, firmware, and documents for that model appears on screen.
3. Click on the name of the desired software or firmware to start downloading the file, or click on the link for device drivers to navigate to a page from which you can select either a driver package or specific drivers for individual devices.

Via the Download Center page

1. Click on the **Download** tab at the top of any page within the Extron website to access the **Download** page.
2. Click on the link for the desired software or software product category (such as Global Configurator Professional, firmware, or control system device drivers) in the center of the screen. A page opens that allows you to make more specific selections from within that category.
3. For **software**, click on the link for the specific software that you need. A software product page opens that provides a description of the software package, a list of system requirements, a list of features, and access to the release notes, in addition to a download link.
For **drivers**:
 - a. Click on the **Control System Drivers** button.
 - b. Select the name of the control processor from the drop-down list.
 - c. Click the link directly below the search fields to download the current “Pro Series driver package” of all available drivers supported by the control processor. Alternatively, navigate through the alphabetically arranged list, search for, locate, and select the device or devices for which you need a driver file.
 - d. To download a single driver rather than the package, click on the appropriate link in the row for the product you want to control to download the driver or to download the “communication sheet.” The communication sheet provides details that may be helpful for working with the product and its control driver.
4. For some software you can click the **Download** or **Download Now** button to begin downloading the software file. For other software there is a link for contacting an Extron support representative who can provide you access to the latest version.

Via links from search results

1. Type the specific name of the software package (such as Global Configurator or Global Scriptor) into the **Search** field in the upper right of the Extron web page and click the **magnifying glass** icon. A search results page opens.
2. Click on the name of the software package. A software product page opens that provides a description of the software package, a list of system requirements, a list of features, and access to the release notes, in addition to a download link.
3. For some software you can click the **Download** or **Download Now** button to begin downloading the software file. For other software there may be a link for contacting an Extron support representative who can provide access to the latest version.

Things to Do After Installing GC and Before Starting a Project

- Read the *Global Configurator Help File*, included with the software, for details and step-by-step procedures on how to start a GC Professional or GC Plus project and perform basic setup tasks for a control processor or collaboration system receiver. The help file provides a wealth of information on settings and how to use the software. It includes examples of how to use the features of GC and step by step instructions for typical configuration tasks.
- Obtain network addresses and related information from your network administrator.
- Set up the IP addresses for the NBP units and for the control processor or collaboration system receiver (see **Step 5: Set up the NBP for Network Communication** on page 18 and **Step 10: Set up the NBP 1200C for Network Communication** on page 35 for an overview of how to set up the network properties of the unit). For details, see the GC help file or Toolbelt help file, which contains instructions on how to set the IP address, gateway IP address, subnet mask, mail server IP address, domain name, web port, SMTP username, and SMTP password so that each device is able to communicate with the network.

Using GC: Helpful Tips

Resources and Notes

- A setup guide (either the *Network Button Panel — Decorator-Style Series Setup Guide*, *Network Button Panel — US Gang Series Setup Guide* or the *NBP 1200C Cable Cubby Enclosure with Network Button Panel Setup Guide*) ships with each NBP unit. The setup guides include a quick reference to the front, rear, and bottom panel features and cover basic hardware installation.
- See **Front Panel Features (All Models) and NBP 1200C Bottom Panel Features** on page 36, **Rear and Side Panel Features and Cabling (Decorator-style and US Gang Models)** on page 16, and **Bottom Panel Features and Cabling (NBP 1200C)** on page 33 for features and for settings for configuring the LAN port.
- If you plan to configure the system at the installation site, Extron recommends downloading drivers for all the devices in the installation **before** you go out to the site.
- The Global Configurator project file (*.gcpro or *.gcplus) contains configuration settings and it can be saved to a directory or folder for backup or for installation on another control processor or collaboration system receiver. Saving a configuration is recommended before you perform a firmware upgrade.
- IP addresses, subnet masks, and gateway address are required during network setup of the system.
- The unit name is any name (for example, Room730-NBP100 or ConfRmSystemNBP) that you want to use to label a specific device. The default is a combination of the product name and part of the hardware (MAC) address. This can be changed to your choice of alphanumeric characters and hyphens (-). The following rules apply:
 - Spaces are not permitted within the name of a unit or at the start or the end of a name.
 - Underscores (_) are not permitted.
 - Valid characters are A-Z, a-z, 0-9, and - (hyphen).
 - The unit does not distinguish between upper and lower case letters.
 - The name cannot start with a number or a hyphen, and it cannot end with a hyphen.
 - Maximum name length is 63 characters.

Troubleshooting

Turn on the input devices (DVD players, Blu-ray players, PCs, and other sources), output devices (display screens, projectors), the controller, and the PC. Push a front panel button or (for US gang models) rotate the **Volume** knob.

If an input or output AV device cannot be remotely controlled (does not respond as expected), check the following:

Power Connections

- Ensure that all devices are plugged in.
- Make sure that each device is receiving power. The front panel buttons light if the unit is receiving power.

Data Connections

1. Check the cabling connections and make adjustments as needed. The Link LEDs on the control processor or collaboration space receiver, the network button panels, and on the PC should be lit green steadily if a network connection is detected. If these LEDs are not lit, the cable is faulty or not plugged in, it is the wrong type of cable or is miswired (see [LAN \(Ethernet\) and PoE connector and LEDs](#) on page 16 and [Bottom Panel Features and Cabling \(NBP 1200C\)](#) on page 33), or the network is “down.”
2. Try to “ping” each device by entering one of the following at the command prompt on the PC:

NOTE: The following commands include the default IP addresses for their respective devices and ports.

- `ping 192.168.254.250` — for a control processor or collaboration system receiver without AV LAN, or for an IPCP Pro control processor AV LAN port when the DHCP server is disabled (default)
- `ping 192.168.253.250` — for the LAN port of an IPCP Pro control processor with AV LAN
- `ping 192.168.245.1` — for an IPCP Pro control processor AV LAN port if the DHCP server is enabled
- `ping 192.168.254.253` — for an NBP button panel

Or ping the IP or web address provided to you by your system administrator.

If you get no response:

- Make sure your unit is using the appropriate subnet mask (check with your system administrator).
 - Make sure your PC and network do not have a software firewall program that might block the IP address of the devices.
 - Ensure that the network is functioning. Try to ping another device, for example.
3. If contact is established with the unit, but the NBP internal web pages cannot be accessed by your browser program, verify that your browser is configured for direct network connection and is not set up to use a proxy server. Use the Internet network options or preferences menu in the browser to check the settings.

Device Control Connections and Configuration

- Verify that ports are wired correctly and that ground (earthing) wires are connected to the proper pins on the control processor or collaboration system receiver, and, if applicable, on controlled devices.
- Verify that the NBP is grounded (see [grounding instructions](#) on page 15).
- Verify that the appropriate drivers were used while creating the GC configuration file and that the correct commands and signal types (IR or RS-232) are associated with the appropriate ports on the control processor or collaboration system receiver and on the other devices.
- Verify that the NBP buttons and knobs (where applicable) are configured correctly.
- For digital input and output connections, verify whether the application requires the +5 VDC pull-up resistor within the control processor or receiver for TTL circuits and use the software to check whether it is selected within the configuration.
- Verify that input current at any digital input or output port on the control processor or receiver does not exceed 250 mA.
- Verify that input at the volume control port on an IPCP Pro 250 does not exceed 10 VDC and that the amplifier is cabled correctly, as well.

If you still experience problems, call the [Extron S3 Sales & Technical Support Hotline](#) or the Extron S3 Control Systems Support Hotline (1.800.633.9877).

Reference Information

This section of the guide includes the following reference items:

- [Network Requirements](#)
- [Secure Sockets Layer \(SSL\) Certificates](#)
- [IEEE 802.1X Certificates](#)

To read product specifications, visit the product page for the NBP model at www.extron.com.

Network Port Requirements

Network administrators may find it useful to know which ports, protocols, and services are used by the button panels, control processors, collaboration receivers, touchpanels, Global Configurator Plus and Professional software, Toolbelt, and Extron Control software. A list of protocols used for inbound and outbound communication for each type of device or software is available in the *Pro Series Control Product Network Ports and Licenses Guide*, part 68-2961-01, available at www.extron.com.

The controllers use various licensed third-party software packages during operation. To view details about third-party packages and associated licensing, click the **License Information** button in the internal web pages of the control processor or receiver. A **License Information** window opens. To view a copy of a listed package license, in the **License Information** window, click the link in the License column for the relevant package. This opens a copy of the package license in a separate window. A list of licenses is also available in the *Pro Series Control Product Network Ports and Licenses Guide* at www.extron.com.

Secure Sockets Layer (SSL) Certificates

Extron NBP button panels, IP Link Pro controllers, and collaboration system receivers ship with factory-installed SSL certificates created by Extron. If you want or are required to use a different SSL certificate at your installation site, then you can use system utilities in the Toolbelt software to change the SSL certificate at any time. The *Toolbelt Help File* provides instructions on how to apply an SSL certificate to a controller.

NOTES:

- You must run Toolbelt as an administrator.
- Some certificates require a passphrase that is created when the certificate is created. If a passphrase is required, you must enter that passphrase before uploading and applying the certificate.

These devices support standard OpenSSL certificate encodings such as .pem (Privacy-enhanced Electronic Mail) and .der (Distinguished Encoding Rules) file types. PEM file types are ASCII encoded and are the required format for uploading to the Extron control product. DER file types are binary encoded and can typically have several file extension variations, such as .crt and .cer. There are many standard tools that can convert from DER to PEM file encodings if needed.

NOTE: A DER format file must be converted to PEM encoding before uploading it to the button panel, control processor, or collaboration receiver.

To properly create the certificate for uploading to Extron control devices, ensure that the certificate file meets the following requirements:

- contains X.509 certificate information
- contains public and private keys
- uses PEM encoding

NOTE: ITU-T standard X.509 covers aspects of public key encryption, digital cryptography, certificates, and validation.

Contact your IT administrator for more information on what tools and policies are required to obtain or create the SSL certificate and, if necessary, the corresponding passphrase.

IEEE 802.1X Certificates

IEEE 802.1X is a standard that enables port-based network access control via an authentication server. The protocol requires that all devices must be authenticated before gaining privileges to access the secure part of the network.

The Extron implementation of 802.1X supports PEAP - MSCHAPV2 and EAP - TLS methods of authentication. This section of the guide details the requirements for any **certificate file** (machine or CA) and the **private key file** (for the machine certificate) to be used in the system.

Extron provides resources for learning about 802.1X implementation:

- The *Extron 802.1X Technology Reference Guide*, available from www.extron.com, is the primary resource for background information, system planning, topology, and how to set up these systems.
- The *Toolbelt Help* file provides detailed step-by-step information on using the software to set up 802.1X for IP Link Pro control systems and on troubleshooting.
- The *802.1X Primer* white paper, also available from www.extron.com, provides a general overview of the protocol and its use within a control system.

NOTES:

- You must run Toolbelt as an administrator.
- Machine certificates require a private key file, which can be encrypted.

Certificate File Requirements

PEM (Privacy-enhanced Electronic Mail) file types are ASCII encoded, and they are the required format for 802.1X authentication for the control processors. DER (Distinguished Encoding Rules) file types are binary encoded and can typically have several file extension variations, such as .crt and .cer.

NOTE: DER encoded files (files with .der, .crt, or .cer extensions that are encoded in DER binary format) must be converted to a PEM encoded file type (.pem) before being used for authentication.

DER encoded certificates must be converted to PEM encoding using a third-party tool. Contact your IT administrator for more information on required tools.

To create the 802.1X security certificate for uploading to Extron control processors, ensure that the certificate file meets the following requirements:

- It contains X.509 certificate information.
- It contains a private key (for machine certificates only).
- It is PEM encoded.
- It has a file extension that is .crt or .pem
- Its file name consists of the following types of valid characters:
 - Alphanumeric (A-Z, a-z, 0-9) characters
 - Some special characters (colon [:], underscore [_], and hyphen [-])

NOTE: Spaces are not permitted anywhere in the name.

Private Key File Requirements

Private key files are required only when employing machine certificates. Follow these requirements for creating a private key:

- Its file name consists of the following types of valid characters:
 - Alphanumeric (A-Z, a-z, 0-9) characters
 - Some special characters (colon [:], underscore [_], and hyphen [-])
- It has a file extension that is .key or .pem.
- It can have optional encryption (via password or passphrase).

Firmware Updates

If the need arises, you can replace the NBP firmware. This section covers the following firmware-related topics:

- [Determining the Firmware Version](#)
- [Updating the Firmware](#)

Determining the Firmware Version

To check which firmware version the button panel is using, do one of the following:

- View the device information in Toolbelt.
- View the general status information section of the NBP embedded web page.

Before using those methods, connect the NBP and the PC to the same network. For details see the [Hardware Features and Installation – Wall-mountable Models](#) section starting on page 7 and the [Software-based Configuration and Control](#) section starting on page 44.

Using Toolbelt Software

1. Open the Toolbelt software.
2. Either add the desired control processor manually or start device discovery and select the desired processor from the list of discovered devices.
3. Click on the IP address link or on the **Manage** icon (gear) in the row for the desired control processor, select the applicable device management tabs, and view the device information.

Using a Browser

The NBP comes with a factory default embedded web page, where you can check the firmware version as follows:

1. Start a browser program.
2. Type the IP address of the NBP into the address field of the browser and log on to the internal web page.
3. Look for the version within one of the information panes.

Updating the Firmware

Firmware upgrade tools require the PC and the NBP to both be connected to an Ethernet network. The instructions for updating the firmware assume you have installed the appropriate software on your PC first.

NOTES:

- You should save the existing configuration to a file (see the *Global Configurator Help File* for instructions) before replacing the firmware. If the file is saved, the configuration can be restored to the control processor or collaboration system receiver later using GC.
- Check the Extron website for firmware-related documents, instructions, patch files, and new firmware files before loading new firmware. We recommend that you read the firmware release notes (available from www.extron.com) before beginning the firmware update.

Locating and Downloading the Firmware

1. Visit the Extron website to find the latest firmware file for the NBP button panel. The easiest way to locate files is through the **Downloads** tab on the web page for the specific model.
2. Download the executable installer file (*.exe) from the website and run the installer program. The program automatically stores the firmware file on the PC in `C:\Program Files\Extron\Firmware` within a folder specific to that version.
3. Write down the firmware filename and location for later use. The filename ends in .eff such as `49-476-50-x.xx.xxxx-yyyy.eff` where `x.xx.xxxx` is the version number.

NOTE: The firmware update file must have a filename extension of .eff. If the file does not have that extension, it does not work properly.

Installing firmware

Firmware can be replaced by using one of the following:

- Global Configurator (using the **Update Firmware** link to Toolbelt)
- Toolbelt (the stand-alone program)

These methods allow you to browse to find and select the appropriate .eff file on your PC and then click an **Upload** button to initiate the firmware upload to the unit.

NOTE: Toolbelt allows you to update multiple devices with the same firmware version simultaneously.

Allow at least a couple minutes for the firmware to finish uploading. At the end of the upload process, the unit partially reboots and loses its connection to the PC. Therefore, to continue using the web page or Toolbelt you need to refresh the web page or reconnect via Toolbelt after the firmware update.

Extron Warranty

Extron Electronics warrants this product against defects in materials and workmanship for a period of three years from the date of purchase. In the event of malfunction during the warranty period attributable directly to faulty workmanship and/or materials, Extron Electronics will, at its option, repair or replace said products or components, to whatever extent it shall deem necessary to restore said product to proper operating condition, provided that it is returned within the warranty period, with proof of purchase and description of malfunction to:

**USA, Canada, South America,
and Central America:**

Extron Electronics
1230 South Lewis Street
Anaheim, CA 92805
U.S.A.

Asia:

Extron Asia Pte Ltd
135 Joo Seng Road, #04-01
PM Industrial Bldg.
Singapore 368363
Singapore

Japan:

Extron Electronics, Japan
Kyodo Building, 16 Ichibancho
Chiyoda-ku, Tokyo 102-0082
Japan

Europe:

Extron Europe
Hanzeboulevard 10
3825 PH Amersfoort
The Netherlands

China:

Extron China
686 Ronghua Road
Songjiang District
Shanghai 201611
China

Middle East:

Extron Middle East
Dubai Airport Free Zone
F13, PO Box 293666
United Arab Emirates, Dubai

Africa:

Extron South Africa
3rd Floor, South Tower
160 Jan Smuts Avenue
Rosebank 2196, South Africa

This Limited Warranty does not apply if the fault has been caused by misuse, improper handling care, electrical or mechanical abuse, abnormal operating conditions, or if modifications were made to the product that were not authorized by Extron.

NOTE: If a product is defective, please call Extron and ask for an Application Engineer to receive an RA (Return Authorization) number. This will begin the repair process.

USA: 714.491.1500 or 800.633.9876

Asia: 65.6383.4400

Europe: 31.33.453.4040 or 800.3987.6673

Japan: 81.3.3511.7655

Africa: 27.11.447.6162

Middle East: 971.4.299.1800

Units must be returned insured, with shipping charges prepaid. If not insured, you assume the risk of loss or damage during shipment. Returned units must include the serial number and a description of the problem, as well as the name of the person to contact in case there are any questions.

Extron Electronics makes no further warranties either expressed or implied with respect to the product and its quality, performance, merchantability, or fitness for any particular use. In no event will Extron Electronics be liable for direct, indirect, or consequential damages resulting from any defect in this product even if Extron Electronics has been advised of such damage.

Please note that laws vary from state to state and country to country, and that some provisions of this warranty may not apply to you.