

PROTEUS™ SMARTY HYBRID

user manual

©2023 ELATION PROFESSIONAL all rights reserved. Information, specifications, diagrams, images, and instructions herein are subject to change without notice. ELATION PROFESSIONAL logo and identifying product names and numbers herein are trademarks of ELATION PROFESSIONAL. Copyright protection claimed includes all forms and matters of copyrightable materials and information now allowed by statutory or judicial law or hereinafter granted. Product names used in this document may be trademarks or registered trademarks of their respective companies and are hereby acknowledged. All non-ELATION brands and product names are trademarks or registered trademarks of their respective companies.

ELATION PROFESSIONAL and all affiliated companies hereby disclaim all liabilities for property, equipment, building, and electrical damages, injuries to any persons, and direct or indirect economic loss associated with the use or reliance of any information contained within this document, and/or because of the improper, unsafe, insufficient and negligent assembly, installation, rigging, and operation of this product.

Elation Professional USA | 6122 S. Eastern Ave. | Los Angeles, CA. 90040
323-582-3322 | 323-832-9142 fax | www.elationlighting.com | info@elationlighting.com

Elation Professional B.V. | Junostraat 2 | 6468 EW Kerkrade, The Netherlands
+31 45 546 85 66 | +31 45 546 85 96 fax | www.elationlighting.eu | info@elationlighting.eu

Elation Professional Mexico | AV Santa Ana 30 | Parque Industrial Lerma, Lerma, Mexico 52000
+52 (728) 282-7070

DOCUMENT VERSION



Due to additional product features and/or enhancements, an updated version of this document may be available online. Please scan the QR Code with your mobile device or visit www.elationlighting.com for the latest revision/update of this manual, before installation and/or programming.

Date	Document Version	Software Version ≥	DMX Channel Modes	Notes
08/28/19	1.0	1.1.3	20 / 34	Initial release.
08/14/20	1.2	N/C	NO CHANGE	Updated thermal
10/16/20	1.4	N/C	NO CHANGE	Updated specifications
3/11/21	1.6	N/C	NO CHANGE	Updated sun protection, FCC, and primary/secondary modes
6/22/21	1.8	N/C	NO CHANGE	Updated Maintenance and Dimensional Drawings.
5/23/22	2.0	N/C	NO CHANGE	Updated Fixture Installation to add orientation guidelines, added E-Loader III notice to System Menu.
7/21/22	2.2	N/C	NO CHANGE	Updated General Information, Gobo Installation, Installation Guidelines; added Remote Device Management (RDM)
02/01/23	2.4	1.3.2	NO CHANGE	Updated RDM, System Menu and Specifications; added IP65 Rated
07/05/23	2.5	N/C	NO CHANGE	Updated General Information, IP65 Rated, Dimensional Drawings, Specifications

CONTENTS

General Information	4
IP65 Rated	5
Warranty (USA Only)	6
Safety Guidelines	7
Discharge Lamp Warning	9
Maintenance Guidelines	10
Fixture Overview	11
Colors, Gobos, Animation	12
Custom Gobos	13
Gobo Installation	14
Torque Settings for Screws	20
Lamp Replacement	22
Installation Guidelines	27
Remote Device Management (RDM)	34
System Menu	35
DMX Channel Functions and Values	43
Error Codes	52
Specifications	53
Dimensional Drawings	54
Optional Accessories FCC Statement	56

GENERAL INFORMATION

INTRODUCTION

Please read and understand the instructions in this manual carefully and thoroughly before attempting to operate this device. These instructions contain important safety and use information. **This device is intended for use by professionally trained personnel only, and is not suitable for private use.**

UNPACKING

Every device has been thoroughly tested and has been shipped in perfect operating condition. Carefully check the shipping carton for damage that may have occurred during shipping. If the carton is damaged, carefully inspect the device for damage, and be sure all accessories necessary to install and operate the device have arrived intact. In the event damage has been found or parts are missing, please contact our customer support team for further instructions. Please do not return this device to your dealer without first contacting customer support. Please do not discard the shipping carton in the trash. Please recycle whenever possible.

BOX CONTENTS

Omega Brackets (x2)
IP Rated 5pin DMX Cable
IP Rated Ethernet RJ45 Cable
Power Cable

CUSTOMER SUPPORT

Contact **ELATION Service** for any product related service and support needs. Also visit forums.elationlighting.com with questions, comments or suggestions.

ELATION SERVICE USA - Monday - Friday 8:00am to 4:30pm PST
323-582-3322 | Fax 323-832-9142 | support@elationlighting.com

ELATION SERVICE EUROPE - Monday - Friday 08:30 to 17:00 CET
+31 45 546 85 63 | Fax +31 45 546 85 96 | support@elationlighting.eu

REPLACEMENT PARTS please visit parts.elationlighting.com

IP65 RATED

The International Protection (IP) rating system is commonly expressed as “IP” (Ingress Protection) followed by two numbers (i.e. IP65), where the numbers define the degree of protection. The first digit (Foreign Bodies Protection) indicates the extent of protection against particles entering the fixture, and the second digit (Water Protection) indicates the extent of protection against water entering the fixture. An IP65 rated lighting fixture is designed and tested to protect against the ingress of dust (6), and low-pressure water jets from any direction (5).

NOTE: THIS FIXTURE IS INTENDED FOR TEMPORARY OUTDOOR USE ONLY!

Maritime/Coastal Environment Installations: A coastal environment is seaside adjacent, and caustic to electronics through exposure to atomized salt-water and humidity, whereas maritime is anywhere within 5-miles of a coastal environment.



NOT suitable for maritime/coastal environment installations. Installing this fixture in a maritime/coastal environment may cause corrosion and/or excessive wear to the interior and/or exterior components of the fixture. Damages and/or performance issues resulting from installation in a maritime/coastal environment will void the manufactures warranty, and will NOT be subject to any warranty claims and/or repairs.

Maritime installations require additional preparation, and additional service intervals may be needed given the maritime use. In general, IP ratings presuppose freshwater conditions VS maritime conditions, which are typically more “caustic” to IP fixtures (both internally and externally). A duty-cycle may also be needed when units are not in use. During times of high humidity and colder temperatures, condensation may occur internally so the fixture may require a duty-cycle to bring it up to running temperature, allowing any accumulation of moisture to be expelled via the vent valve. Recommendations can change based on installation environmental circumstances. A waterproof dome or similar device is recommended for use in permanent outdoor installations. When using a dome, refer to manufacturer recommendations for duty-cycle.

NOTE: NOT ALL FEATURES LISTED ARE AVAILABLE ON ALL FIXTURES; THE FOLLOWING INSTRUCTIONS MAY NOT APPLY. CONTACT SUPPORT FOR ADDITIONAL DETAILS.

Exterior Maintenance: Inspect the exterior every 30-days. The unit must be powered off/disconnected. The chassis should be inspected for any signs of contaminants. Inspect optics to determine if the lens is obstructed, then clean optics and chassis accordingly. Based on initial finding, schedule maintenance accordingly, keeping in mind that exterior maintenance will be required. Even if the luminaires are NOT in use, maintenance will still be needed given its location (exterior use). The use of a durable type of wax on the chassis is recommended since it will help prevent contaminant build up. Inspect both power and data lines for any signs of contaminants or corrosion. Periodically reapplying di-electric grease, especially in coastal environments. If any signs of corrosion/contaminants are present, clean thoroughly, and/or replace connectors, then reapply di-electric grease. Typically, this should be done annually, or any time an opportunity presents itself. As a preventive measure, annual replacement of both vent valves is recommended. The vent valve membrane can become contaminated and/or clogged causing improper venting of humidity within the luminaire. Inspect all mounting hardware as a precaution.

Interior Maintenance: Inspect the interior every 30-days. The unit must be powered off/disconnected.

- Inspect zoom/focus mechanism, clean optics, lubricate linear bearings (Krytox oil) as needed, inspect belts for wear
- Inspect all rotating effect wheels, manually rotate them, note any resistance
- Inspect all remaining rotating belts for any wear
- Inspect all fans, clean as needed, check rotation, check connections
- Inspect CMY module, manually move flags and check for signs of resistance, and if needed, clean guide rods first, then reapply a thin layer of grease (moly lube)
- Clean interior with low-volume compressed air, then clean optics prior to reassembly of head covers

Although the base has limited moving parts, the pan belt should also be inspected for wear. Remember to always perform an IP test anytime a cover is removed.

There is no specific time frame regarding the routine replacement of parts such as belts/stepper motors, PCBs, or LEDs. These items should only be replaced on an as needed bases, except for cooling fans, which should be replaced once the luminaries reach 10,000-hours. This is a prophylactic measure intended to keep the unit running as cool as possible, insuring proper function of all internal components. A complete service breakdown is available, please contact service@elationlighting.com for any needed parts or manuals.

WARRANTY (USA ONLY)

- A. This ULTIMATE WARRANTY covers the first two years of operation or 6,000 hours of use, whichever comes first, based on regular maintenance for the fixture and lamp. This comprehensive warranty for a 2-year period covers material and workmanship of the fixture, including the highly efficient Philips Platinum FLEX 200 lamp. Elation Professional warrants product rechargeable batteries to be free of manufacturing defects in material and workmanship for a period of six months (180 days) from the original date of purchase. This warranty shall be valid only if the product is purchased within the United States of America, including possessions and territories. It is the owner's responsibility to establish the date and place of purchase by acceptable evidence, at the time service is sought.
- B. For warranty service, send the product only to the Elation Professional factory. All shipping charges must be pre-paid. If the requested repairs or service (including parts replacement) are within the terms of this warranty, Elation Professional will pay return shipping charges only to a designated point within the United States. If any product is sent, it must be shipped in its original package and packaging material. No accessories should be shipped with the product. If any accessories are shipped with the product, Elation Professional shall have no liability whatsoever for loss and/or or damage to any such accessories, nor for the safe return thereof.
- C. This warranty is void if the product serial number and/or labels are altered or removed; if the product is modified in any manner which Elation Professional concludes, after inspection, affects the reliability of the product; if the product has been repaired or serviced by anyone other than the Elation Professional factory unless prior written authorization was issued to purchaser by Elation Professional; if the product is damaged because not properly maintained as set forth in the product instructions, guidelines and/or user manual.
- D. This is not a service contract, and this warranty does not include any maintenance, cleaning, or periodic check-up. During the periods as specified above, Elation Professional will replace defective parts at its expense, and will absorb all expenses for warranty service and repair labor by reason of defects in material or workmanship. The sole responsibility of Elation Professional under this warranty shall be limited to the repair of the product, or replacement thereof, including parts, at the sole discretion of Elation Professional. All products covered by this warranty were manufactured after January 1, 1990, and bare identifying marks to that effect.
- E. Elation Professional reserves the right to make changes in design and/or performance improvements upon its products without any obligation to include these changes in any products theretofore manufactured.
- F. No warranty, whether expressed or implied, is given or made with respect to any accessory supplied with the products described above. Except to the extent prohibited by applicable law, all implied warranties made by Elation Professional in connection with this product, including warranties of merchantability or fitness, are limited in duration to the warranty periods set forth above. And no warranties, whether expressed or implied, including warranties of merchantability or fitness, shall apply to this product after said periods have expired. The consumer's and/or dealer's sole remedy shall be such repair or replacement as is expressly provided above; and under no circumstances shall Elation Professional be liable for any loss and/or damage, direct and/or consequential, arising out of the use of, and/or the inability to use, this product.
- G. This warranty is the only written warranty applicable to Elation Professional products and supersedes all prior warranties and written descriptions of warranty terms and conditions heretofore published.

WARRANTY RETURNS

All returned service items whether under warranty or not, must be freight pre-paid and accompany a return authorization (R.A.) number. The R.A. number must be clearly written on the outside of the return package. A brief description of the problem as well as the R.A. number must also be written down on a piece of paper and included in the shipping container. If the unit is under warranty, you must provide a copy of your proof of purchase invoice. Items returned without a R.A. number clearly marked on the outside of the package will be refused and returned at customer's expense. You may obtain a R.A. number by contacting customer support.

SAFETY GUIDELINES

This fixture is a sophisticated piece of electronic equipment. To guarantee a smooth operation, it is important to follow all instructions and guidelines in this manual. Elation Professional is not responsible for injury and/or damages resulting from the misuse of this fixture due to the disregard of the information printed in this manual. Only qualified and/or certified personnel should perform installation of this fixture and only the original rigging parts (omega brackets) included with this fixture should be used for installation. Any modifications to the fixture and/or the included mounting hardware will void the original manufactures warranty and increase the risk of damage and/or personal injury.



PROTECTION CLASS 1 - FIXTURE MUST BE PROPERLY GROUNDED



**THERE ARE NO USER SERVICEABLE PARTS INSIDE THIS UNIT.
DO NOT ATTEMPT ANY REPAIRS YOURSELF; DOING SO WILL VOID YOUR MANUFACTURES WARRANTY. DAMAGES RESULTING FROM MODIFICATIONS TO THIS FIXTURE AND/OR THE DISREGARD OF SAFETY INSTRUCTIONS AND GUIDELINES IN THIS MANUAL VOID THE MANUFACTURES WARRANTY AND ARE NOT SUBJECT TO ANY WARRANTY CLAIMS AND/OR REPAIRS.**



**DO NOT PLUG FIXTURE INTO A DIMMER PACK!
NEVER OPEN THIS FIXTURE WHILE IN USE!
UNPLUG POWER BEFORE SERVICING FIXTURE!
NEVER TOUCH FIXTURE DURING OPERATION, AS IT MAY BE HOT!
KEEP FLAMMABLE MATERIALS AWAY FROM FIXTURE!**



**NEVER LOOK DIRECTLY INTO THE LIGHT SOURCE!
RETINA INJURY RISK - MAY INDUCE BLINDNESS!
SENSITIVE PERSONS MAY SUFFER AN EPILEPTIC SHOCK!**



ENSURE ALL CONNECTIONS AND END CAPS ARE PROPERLY SEALED WITH A DIELECTRIC GREASE (AVAILABLE AT MOST ELECTRICAL SUPPLIERS) TO PREVENT WATER CORROSION AND/OR ELECTRICAL SHORT CIRCUIT.



**MINIMUM DISTANCE TO OBJECTS/SURFACES
MUST BE 49.2 FEET (15 METERS)
MAXIMUM TEMP OF EXTERNAL SURFACE 185° F (85°C)
MINIMUM DISTANCE OF INFLAMMABLE MATERIALS
FROM THE SURFACE 1.6 FEET (0.5 METER)**

SAFETY GUIDELINES

CAUTION

**HIGH
INTENSITY
ULTRAVIOLET
LIGHT**



AVOID DIRECT EYE & SKIN EXPOSURE.
WEAR PROPER EYE & SKIN PROTECTION.
SEE MANUAL FOR SAFETY INSTRUCTIONS.

RISK GROUP 3 - RISK OF EXPOSURE TO ULTRAVIOLET UV RADIATION! FIXTURE EMITS HIGH INTENSITY WAVELENGTH OF ULTRAVIOLET UV LIGHT FROM THE UV COLOR FILTER. WEAR PROPER EYE AND SKIN PROTECTION. AVOID PROLONGED PERIODS OF EXPOSURE TO UV COLOR FILTER. AVOID WEARING WHITE COLOR CLOTHING AND/OR USING UV PAINTS ON SKIN. AVOID DIRECT EYE AND/OR SKIN EXPOSURE AT DISTANCES LESS THAN 11 feet (3.3m). DO NOT OPERATE FIXTURE WITH DAMAGED/MISSING EXTERNAL COVERS. DO NOT LOOK DIRECTLY

INTO THE UV LIGHT AND/OR VIEW UV LIGHT DIRECTLY WITH OPTICAL INSTRUMENTS THAT MAY CONCENTRATE THE LIGHT/RADIATION OUTPUT. INDIVIDUALS SUFFERING FROM A RANGE OF EYE CONDITIONS, SUNLIGHT EXPOSURE DIS-ORDERS, OR INDIVIDUALS USING PHOTSENSITIVE MEDICATION, MAY RECEIVE DISCOMFORT IF EXPOSED TO THE ULTRAVIOLET UV LIGHT EMITTED FROM THE UV LED.

DO NOT TOUCH the fixture housing during operation. Turn OFF the power and allow approximately 15 minutes for the fixture to cool down before serving.

DO NOT shake fixture, avoid brute force when installing and/or operating fixture.

DO NOT operate fixture if the power cord is frayed, crimped, damaged and/or if any of the power cord connectors are damaged and do not insert into the fixture securely with ease. **NEVER** force a power cord connector into the fixture. If the power cord or any of its connectors are damaged, replace it immediately with a new one of similar power rating.

DO NOT block any air ventilation slots.

All fan and air inlets must remain clean and never blocked.

Allow approx. 6" (15cm) between fixture and other devices or a wall for proper cooling.

Always disconnect fixture from main power source before performing any type of service and/or cleaning procedure. Only handle the power cord by the plug end, never pull out the plug by tugging the wire portion of the cord.

During the initial operation of this fixture, a light smoke or smell may emit from the interior of the fixture. This is a normal process and is caused by excess paint in the interior of the casing burning off from the heat associated with the lamp and will decrease gradually over time.

Consistent operational breaks will ensure fixture will function properly for many years.

ONLY use the original packaging and materials to transport the fixture in for service.

DISCHARGE LAMP WARNING

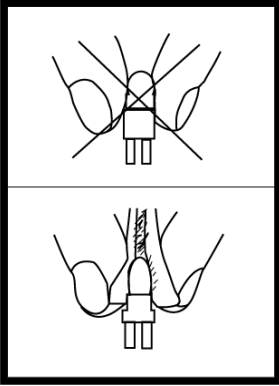

This fixture is fitted with a DISCHARGE LAMP, which is highly susceptible to damage if improperly handled. NEVER touch the lamp with your bare hands, as the oil from your hands will shorten the life of the lamp. NEVER move the fixture until the lamp has had ample time to cool. DISCHARGE LAMPS are NOT covered under warranty conditions. Avoid switching the fixture ON and OFF repeatedly in short intervals, as this will reduce lamp life and intensity. To achieve the intensity associated with discharge lamps, these lamps use gas sealed in a high-pressure environment to emit a brilliant output.

Due to the high pressure involved with the construction of the lamp, it **MAY EXPLODE DURING PROLONGED EXTENSIVE USE**. This risk is increased with age; added care is encouraged when dealing with older lamps. Thus, the lamp must always be replaced at the end of their recommended duty cycle. Extreme caution should be used when operating this or any fixture fitted with a gas discharge lamp.

UV RADIATION NOTICE



THIS FIXTURE EMITS INTENSE UV RADIATION, WHICH IS HARMFUL TO THE EYES AND SKIN. THE INTENSE LUMINANCE OF THE LAMP CAN CAUSE SEVERE DAMAGE TO THE RETINA. NEVER OPERATE THIS FIXTURE WITH ANY OF THE PROTECTIVE COVERS REMOVED. THESE COVERS HAVE BEEN SPECIALLY DESIGNED TO SHIELD AGAINST UV RADIATION.

LAMP REPLACEMENT

USE ONLY GENUINE ORIGINAL PHILIPS™ LAMPS. OTHER BRAND LAMPS WILL CAUSE DAMAGE AND WILL VOID FIXTURE WARRANTY!



**DISCONNECT THE MAIN POWER SUPPLY BEFORE REPLACING LAMP!
FIXTURE MUST COOL FOR 60 MINUTES BEFORE REPLACING LAMP!**

**NEVER TOUCH LAMP WITH BARE HANDS, ALWAYS WEAR GLOVES!
OIL FROM HANDS WILL SHORTEN LIFE OF LAMP!**

MAKE SURE ALL COVERS/PANELS ARE REPLACED/SECURED BEFORE OPERATING FIXTURE TO PREVENT ANY RISK AND/OR DAMAGE TO EYE RETINA FROM UV RADIATION EXPOSURE!

MAINTENANCE GUIDELINES



DISCONNECT POWER BEFORE PERFORMING ANY MAINTENANCE!

CLEANING

Frequent cleaning is recommended to insure proper function, optimized light output, and an extended life. The frequency of cleaning depends on the environment in which the fixture operates: damp, smoky or particularly dirty environments can cause greater accumulation of dirt on the fixture's optics. Clean the external lens surface at least every 20 days with a soft cloth to avoid dirt/debris accumulation.

NEVER use alcohol, solvents, or ammonia-based cleaners.

MAINTENANCE

Regular inspections are recommended to insure proper function and extended life.

There are no user serviceable parts inside this fixture, please refer all other service issues to an authorized Elation service technician. Should you need any spare parts, please order genuine parts from your local Elation dealer.

Please refer to the following points during routine inspections:

- A detailed electric check by an approved electrical engineer every three months, to make sure the circuit contacts are in good condition and prevent overheating.
- Be sure all screws and fasteners are securely tightened at all times. Loose screws may fall out during normal operation resulting in damage or injury as larger parts could fall.
- Check for any deformations on the housing, color lenses, rigging hardware and rigging points (ceiling, suspension, trussing). Deformations in the housing could allow for dust to enter into the fixture. Damaged rigging points or unsecured rigging could cause the fixture to fall and seriously injure a person(s).
- Electric power supply cables must not show any damage, material fatigue or sediments.
NEVER remove the ground prong from the power cable.

FIXTURE DISASSEMBLY

The following points should be observed after performing any maintenance procedure that requires disassembly of the unit:

- After the unit has been reassembled, open the valve, and allow the light to run for approximately 2 hours in order to dry out any moisture that has been trapped inside the fixture. The process should continue until indicated humidity drops below 15% for the head and 30% for the base.
- Once this has been achieved, the light can be switched off, but the unit should remain connected to power so that the cooling fan can cool down the unit. Please note that allowing cool down time should ALWAYS be done after lamp operation.
- Some units may require partial disassembly in order to gain access to the valve. Please contact Elation service for information regarding the location and access procedure for the valve on your specific unit model.

FIXTURE OVERVIEW

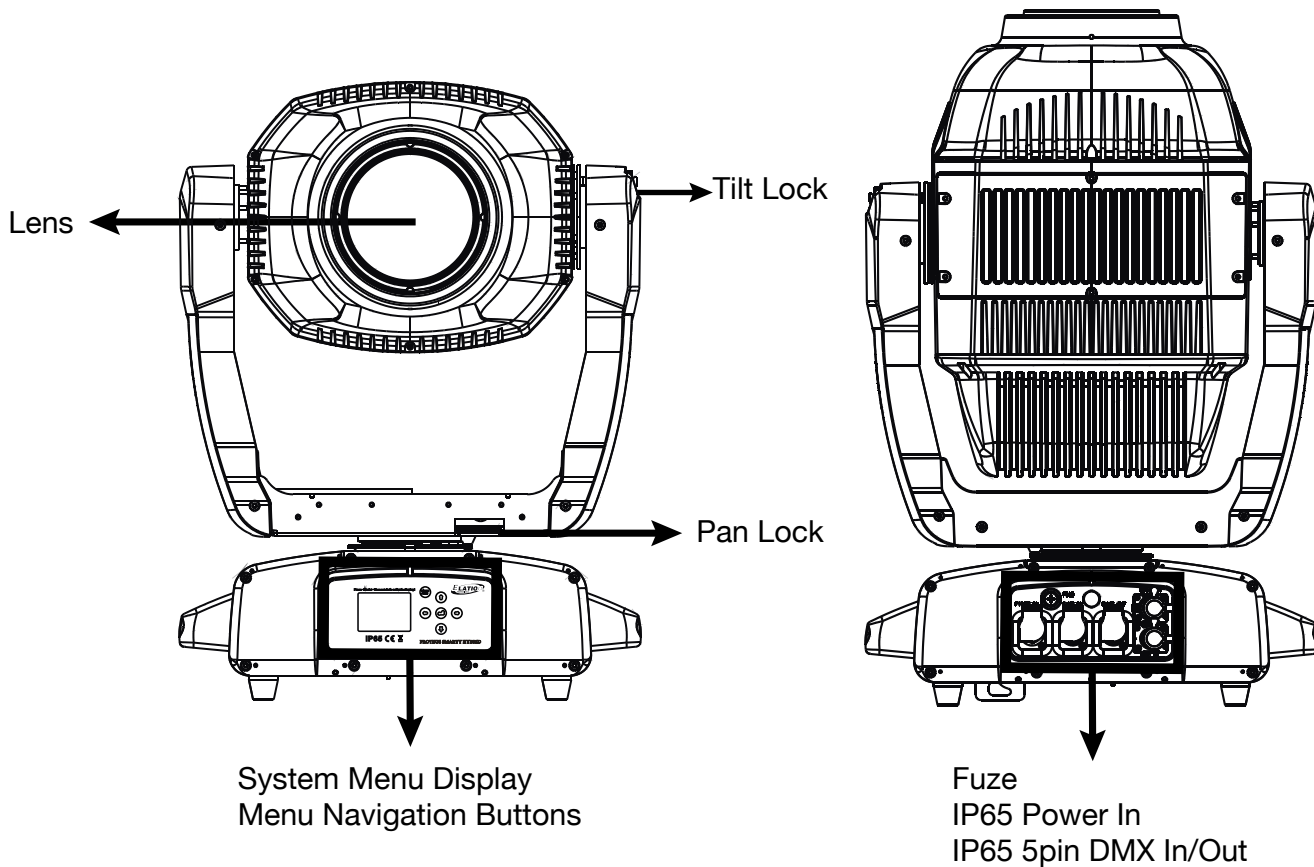

SAFETY CABLE ATTACHMENT

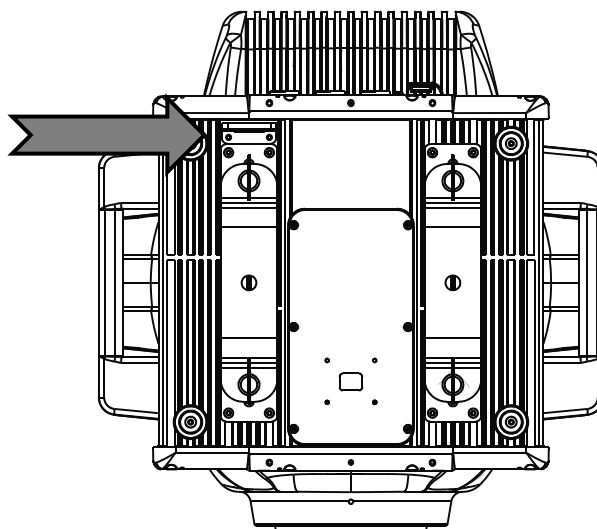

ALWAYS ATTACH A SAFETY CABLE WHENEVER INSTALLING THIS DEVICE IN A SUSPENDED ENVIRONMENT TO ENSURE THE FIXTURE WILL NOT

COLORS, GOBOS, ANIMATION

COLOR WHEEL

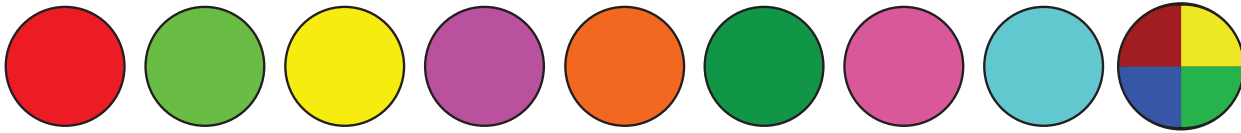

1 Red 2 Green 3 Yellow 4 Magenta 5 Orange 6 Aqua 7 Pink 8 Cyan 9 RYBG



10 CTB 11 UV 12 CTO 13 Blue

COLOR FLAGS



CYAN MAGENTA YELLOW

INTERCHANGEABLE-ROTATING GLASS GOBO WHEEL 1



1 2 3 4 5 6 7 8

STATIC-FIXED METAL GOBO WHEEL 2



1 2 3 4 5 6 7 8 9 10 11 12

CUSTOM GOBOS

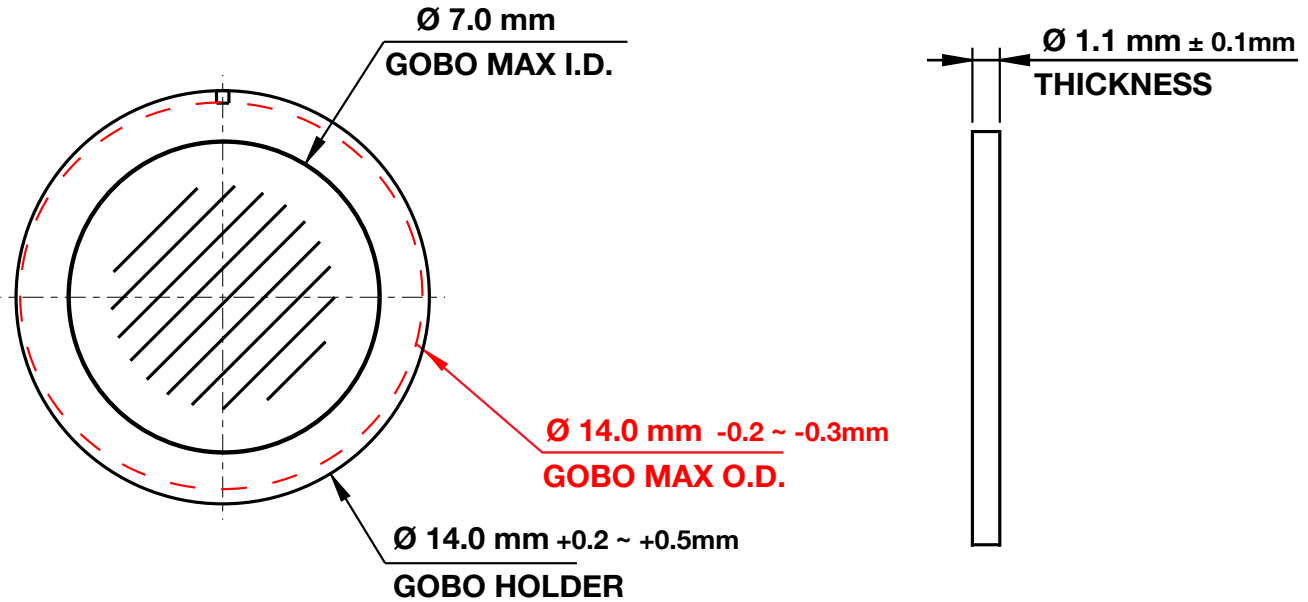

ROTATING GLASS GOBOS - WHEEL 1	
Gobo O.D. (Max. Outer Diameter)	$\text{Ø } 14\text{mm } -0.2\sim-0.3\text{mm}$
Gobo I.D. (Max. Image Diameter)	$\text{Ø } 7\text{mm}$
Gobo Holder Diameter	$\text{Ø } 14\text{mm } +0.2\sim+0.5\text{mm}$
Gobo Thickness	$\text{Ø } 1.1\text{mm } \pm 0.1\text{mm}$
Gobo Material	BOROFLOAT

*** * * IMPORTANT NOTICE REGARDING CUSTOM GOBOS * * ***

Due to the high temperature optical system, special material as listed above is required for custom gobos. Due to varying manufacturing processes and tolerances, it is highly recommended to provide a gobo sample and holder from the fixture to the custom gobo vendor for accurate sizing. Extended testing of custom gobo designs is highly recommended prior to use. Contact ELATION SERVICE for further information.

ELATION SERVICE USA - Monday - Friday 8:00am to 5:00pm PST

Voice: 323-582-3322

Fax: 323-832-9142

E-mail: support@elationlighting.com

ELATION SERVICE EUROPE - Monday - Friday 08:30 to 17:00 CET

Voice: +31 45 546 85 30

Fax: +31 45 546 85 96

E-mail: support@elationlighting.eu

GOBO INSTALLATION



WARNING! GOBO REPLACEMENT SHOULD ONLY BE DONE BY A TRAINED TECHNICIAN.

1. Turn OFF power and allow approximately 60 minutes for the fixture to cool down.



2. Before removing panels, place fixture on a stable flat surface in an **INDOOR DUST FREE** location. Ensure moving head is locked into place into a neutral upright position, with both **PAN** and **TILT** locks engaged.



3. Remove front and back panels; each are secured with (6x) 3mm hex-head screws.

GOBO INSTALLATION

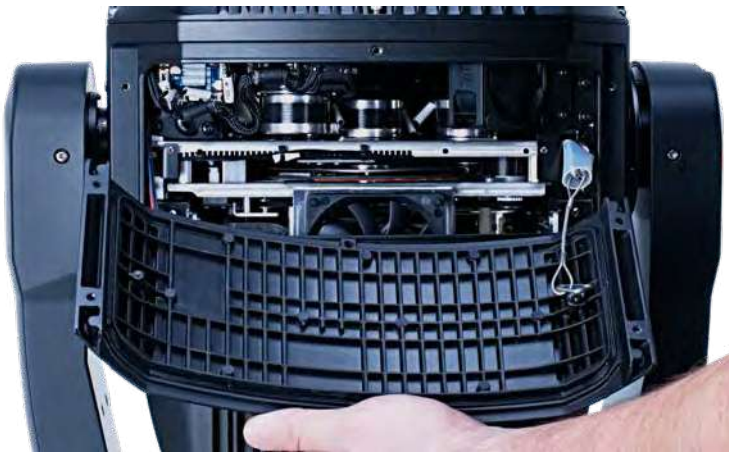

4. One at a time, gently lift panels away and unclip the safety cable to remove them completely from the fixture.

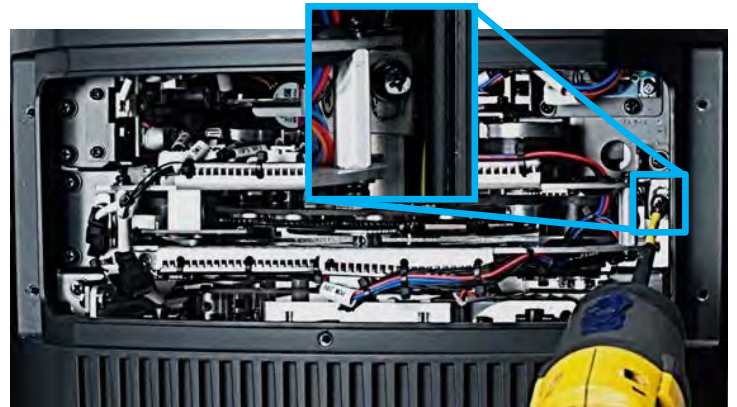
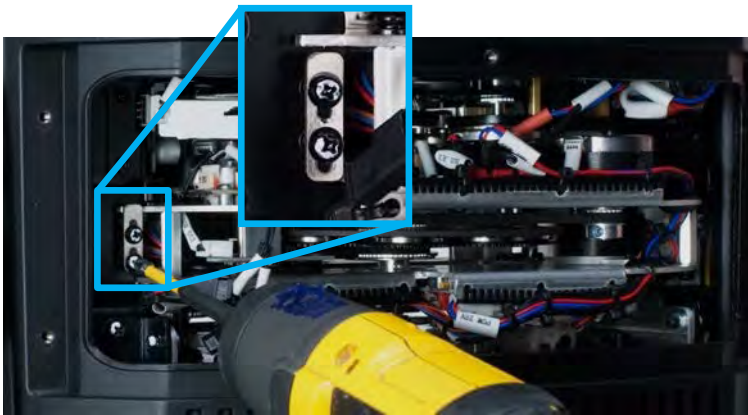

5. Loosen (3x) Phillips head screws securing the GOBO Wheel Module brackets, allowing them to slide freely.

GOBO INSTALLATION

6. Before removing the GOBO Wheel Module, locate the 4 wire connectors and carefully unplug them. (See connectors in photos 6a, 6b, 6c, and 6d) **DO NOT USE FORCE TO REMOVE!**

6a

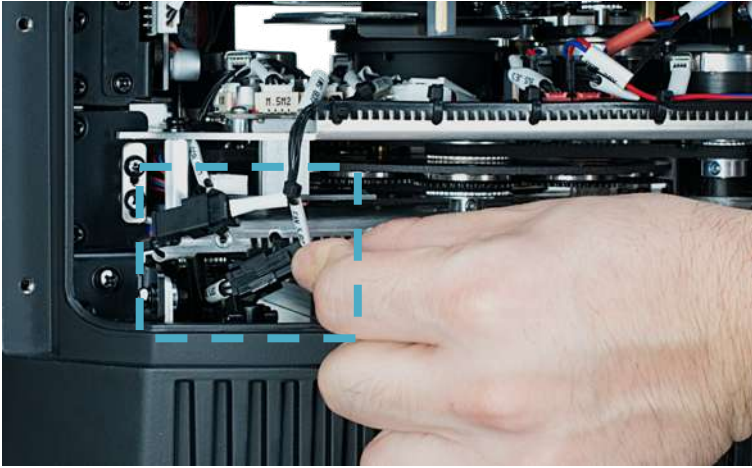

6b

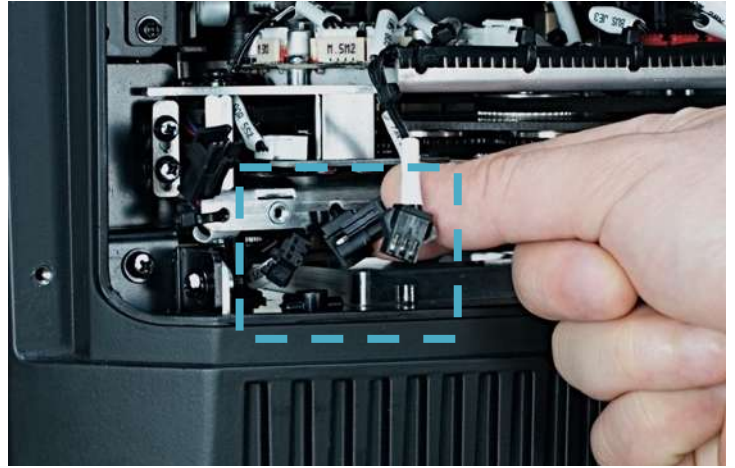

6c

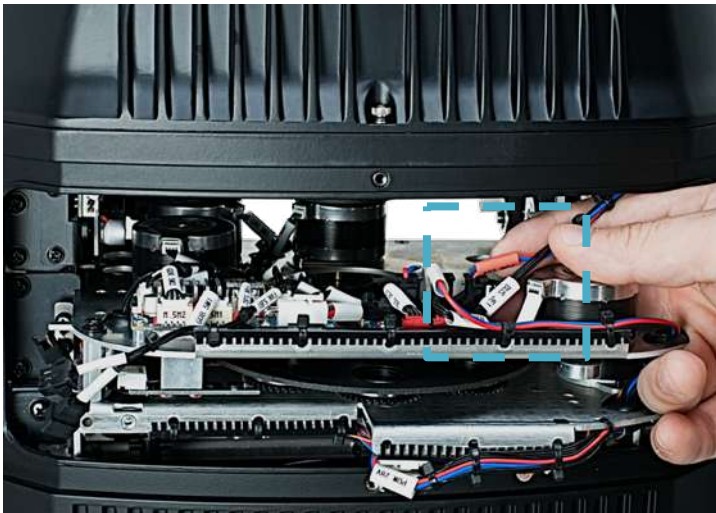

6d

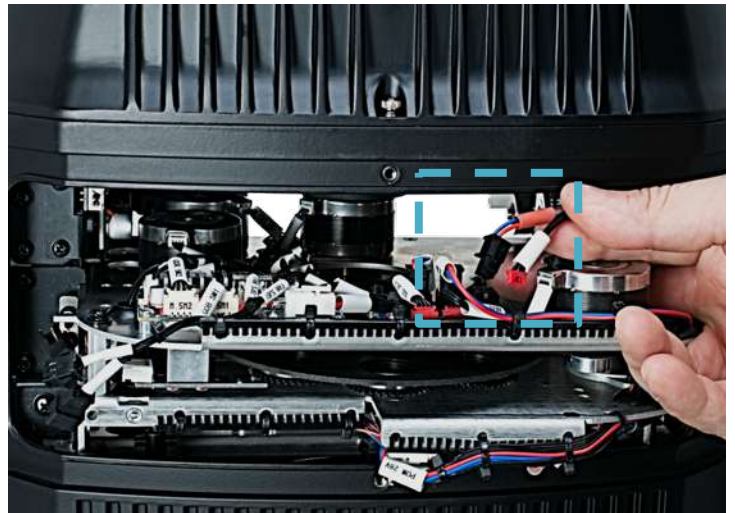

GOBO INSTALLATION

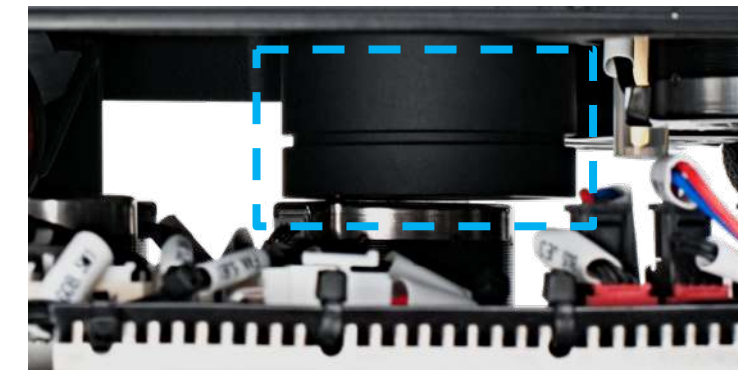
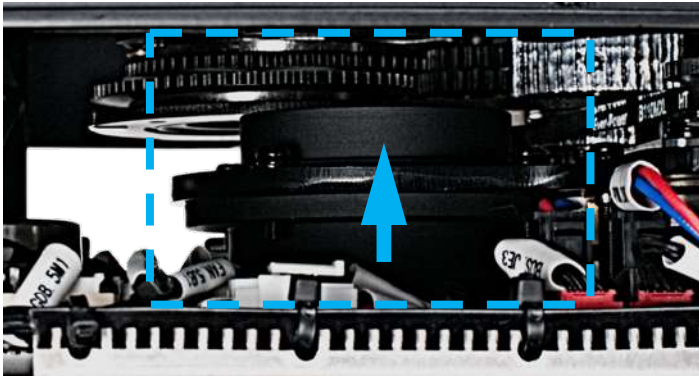

7. Lift/Push the Lens to clear GOBO Wheel Module. If it is difficult to access the Lens, it may be necessary to tilt the head over, allowing gravity to slide the Lens out of the way.



8. Carefully grip the GOBO Wheel Module and slide it out and away to clear the mounting rails.

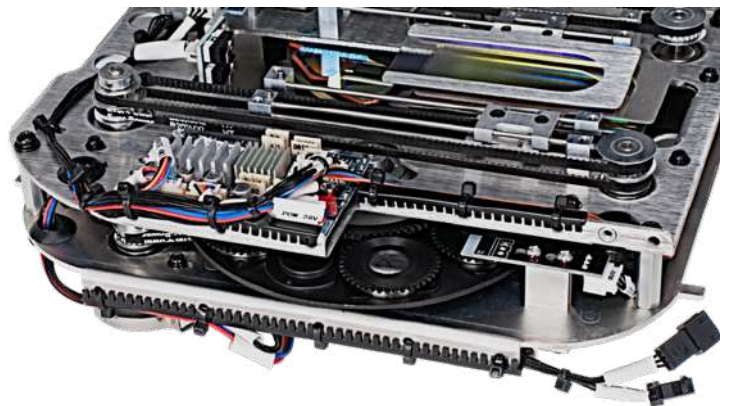

9. Carefully place the GOBO Wheel Module on a stable flat surface in an **INDOOR DUST FREE** location.

GOBO INSTALLATION

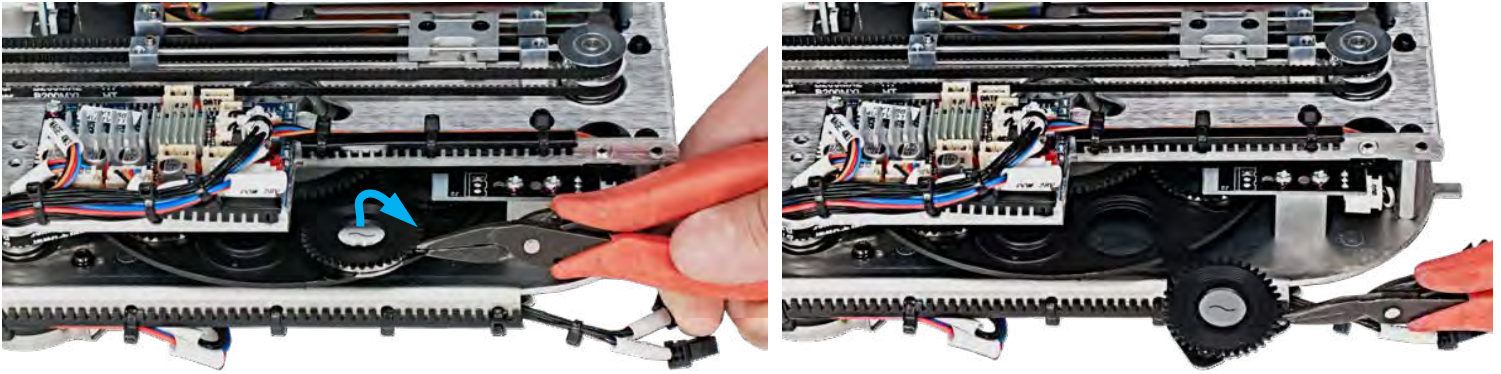

10. REPLACING A ROTATING GOBO

Carefully lift the GOBO Holder up and out from the GOBO Wheel using small needle nose pliers. Take care not to scratch the GOBO and GOBO Holder when removing it from the GOBO Wheel Module.



11. Locate the tab of the retaining spring. Using a precision pick (or similar tool), carefully press the retaining spring inward to relieve the tension. Remove the retaining spring and carefully separate the GOBO from the GOBO Holder. Install the replacement GOBO following the steps above in reverse order.



CAUTION: TAKE CARE NOT TO SCRATCH GOBO OR GOBO HOLDER

GOBO INSTALLATION

GASKET INSPECTION



CAREFULLY REMOVE ANY DEBRIS FOUND ON GASKET AND SCREW HOLES OF BOTH CENTER PANELS USING A NONABRASIVE BRUSH BEFORE INSTALLING!

CAREFULLY INSPECT GASKETS FOR SIGNS OF WEAR SUCH AS CRACKING OR HARDENING, DEFORMITIES, OR ALIGNMENT ISSUES BEFORE INSTALLING!

ITEMS ABOVE CAN IMPEDE THE IP65 INTEGRITY AND/OR CAUSE INTERNAL DAMAGE. CONTACT ELATION SERVICE REGARDING GASKET REPLACEMENT IF NEEDED.

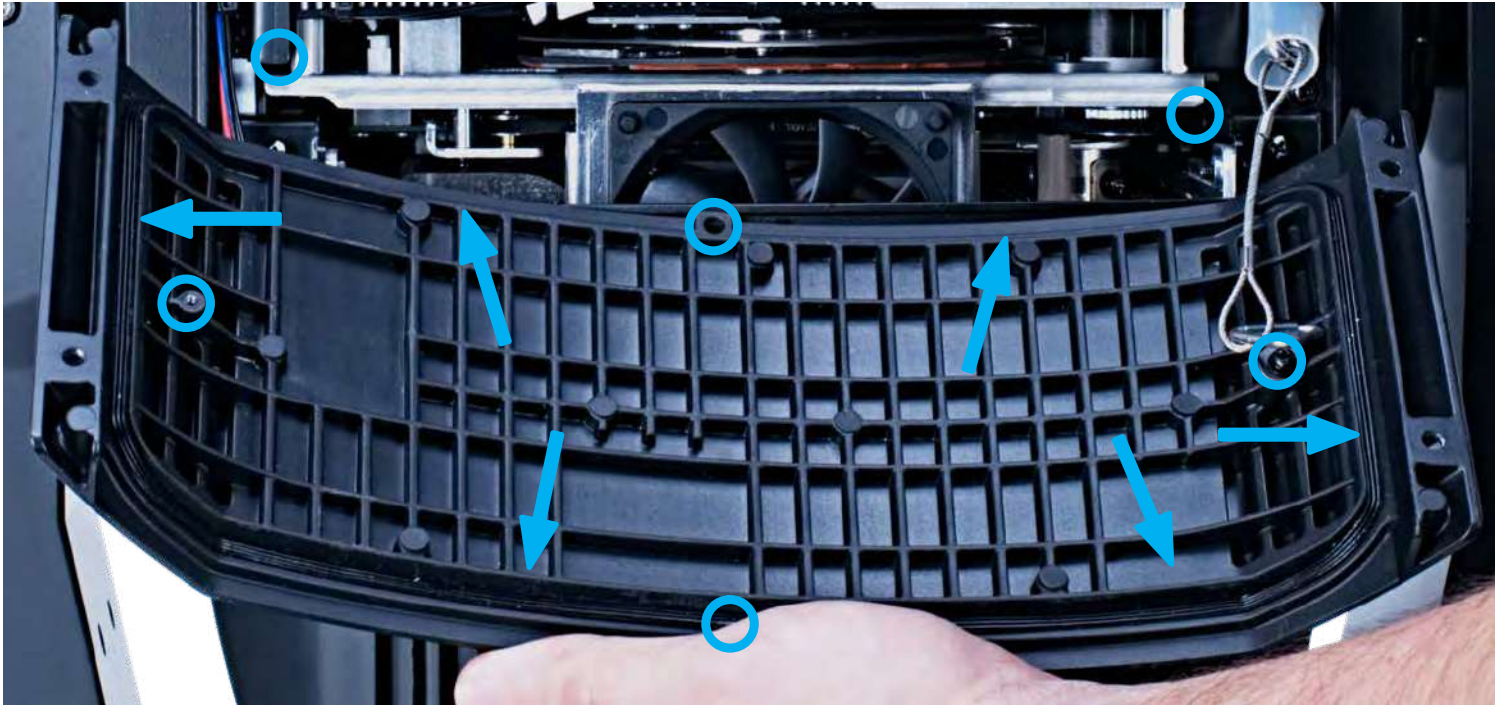

TORQUE SETTINGS FOR SCREWS

TORQUE SETTINGS FOR PANEL SCREWS



PANEL SCREWS MUST BE TIGHTED WITH A TORQUE WRENCH!



The (12x) hex-head screws holding the panels **MUST** be tightened with a torque wrench (not included).

TORQUE SETTING = 11 lbf-in. (12.7kgf-cm) *

*** lbf-in = Pound Force Inches | kgf-cm = Kilogram Force Centimeters**

TORQUE SETTINGS FOR SCREWS



CAUTION! DO NOT OVER TORQUE SCREWS AS THIS CAN CAUSE LEAKAGE ISSUES! TO CONFIRM THE IP65 INTEGRITY AFTER A GOBO REPLACEMENT, TEST FIXTURE USING THE ELATION IP TESTER. CONTACT ELATION SERVICE FOR MORE DETAILS.



CAUTION! THE USE OF PROTECTIVE GLOVES AND SAFETY GOGGLES IS STRONGLY RECOMMENDED WHILE PERFORMING THE IP PRESSURE TEST! AVOID PLACING YOUR FACE, EYES, HANDS, ETC IN CLOSE PROXIMITY TO THE FIXTURE'S LENS WHILE



IP PRESSURE TESTING PARAMETERS			
Test Type	Low Pressure Limit	High Pressure Limit	Hold Time
Vacuum Test	-4.35 psi (-30.00 KPa)	-5.08 psi (-35.00 KPa)	10 sec
Pressure Test	3.62 psi (25.00 KPa)	4.35 psi (30.00 KPa)	10 sec

LAMP REPLACEMENT

To ensure a proper/safe lamp change, carefully read all the following instructions.

USE ONLY GENUINE ORIGINAL PHILIPS™ LAMPS. OTHER BRAND LAMPS WILL CAUSE DAMAGE AND WILL VOID FIXTURE WARRANTY!



**DISCONNECT THE MAIN POWER SUPPLY BEFORE REPLACING LAMP!
FIXTURE MUST COOL FOR 60 MINUTES BEFORE REPLACING LAMP!
NEVER TOUCH LAMP WITH BARE HANDS, ALWAYS WEAR GLOVES!
OIL FROM HANDS WILL SHORTEN LIFE OF LAMP!**

MAKE SURE ALL COVERS/PANELS ARE REPLACED/SECURED BEFORE OPERATING FIXTURE TO PREVENT ANY RISK AND/OR DAMAGE TO EYE RETINA FROM UV RADIATION EXPOSURE!

LAMP PROTECTION CIRCUITRY

The fixture LCD Menu Control Display will indicate the lamp life and related lamp warnings with each power ON, each lamp strike, and when specific lamp hours are reached. The table below provides details on each lamp life warning. Due to the extreme heat associated with the lamp and the nature of the internal optical system, it is **IMPERATIVE** the lamp is replaced when the LCD Menu Control Display indicates replacement is needed. This is done to protect the internal optical system as well as prevent accidental lamp explosion, which could lead to hot glass particles falling from the fixture.

Total Lamp Hours = X – 20%

LCD display will slowly blink with a YELLOW outline and the following warning for 10 mins:
“LAMP LIFE left “X” hours. Please change lamp soon”
Sending a DMX value of 250-251 in Channel 24 (Standard Mode) or Channel 34 (Extended Mode) from the lighting controller or pressing the OK button on the fixture control panel will clear this warning.

Total Lamp Hours = X up to X + 20%

LCD display will slowly blink with a RED outline and the following warning for 10 mins:
“LAMP LIFE exceeded by “X” hours. Please change lamp immediately”
Sending a DMX value of 250-251 in Channel 24 (Standard Mode) or Channel 34 (Extended Mode) from the lighting controller or pressing the OK button on the fixture control panel will clear this warning.

Total Lamp Hours = X + 20% and higher

LCD display will slowly blink RED Outline and the following warning:
“Lamp Life “X” hours. Danger of lamp explosion and permanent fixture damage. Replace lamp immediately! User assumes all risks”
This error can ONLY be cleared when the lamp hours are reset.

LAMP REPLACEMENT



LAMP LIFE OF PHILIPS PLATINUM 200 FLEX = UP TO 6,000 HOURS

Lamp hours are calculated in real time by a smart algorithm combining periods of full output and periods of hibernation with the shutter closed. To reach 6,000 hours the fixture must be operated in average entertainment usage patterns that contain cycles of closed shutters to enter hibernation mode. On average this will allow to the fixture to reach 6,000 hours under common entertainment operation cycles as defined by Philips as 30% operation, 70% hibernation. In the rare case that the fixture Smarty would be turned on, shutter opened and never closed again the lamp life is 2000 hours. Lamp life idle, total time and an estimated total lamp life % are provided in the display of the fixture.

WARNING! LAMP REPLACEMENT SHOULD ONLY BE DONE BY A TRAINED TECHNICIAN.

1. Turn OFF power and allow approximately 60 minutes for the fixture to cool down.



2. Place head in a 90-degree horizontal position.

Engage **PAN and TILT** locks for added stability while replacing the lamp.

LAMP INSTALLATION



3. Remove (4x) 3mm hex-head screws to remove the rear cover.



4. Unclip the rear panel safety cable.



5. Locate 2 wire connectors to the heatsink module.



6. Carefully unplug these two wire connectors.
It may be necessary to use a precision pick or similar tool to gently unlock each connector.

DO NOT USE FORCE TO REMOVE!



LAMP INSTALLATION



7. Remove (4x) 3mm hex-head screws holding the heatsink module.
Carefully rotate heatsink module down 90° to rest on brackets. **DO NOT USE FORCE!**

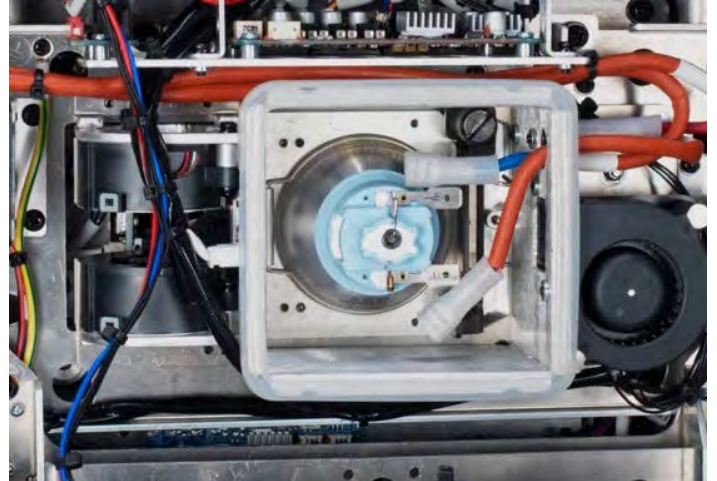
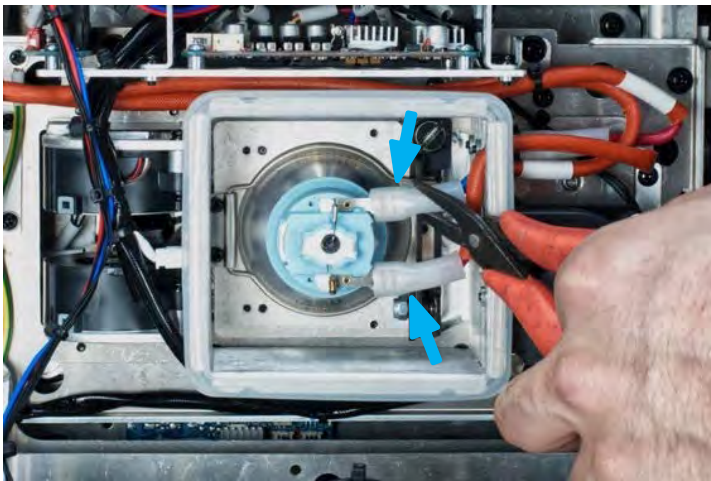

8. Gently remove the (2x) spade terminals connected to the lamp base.

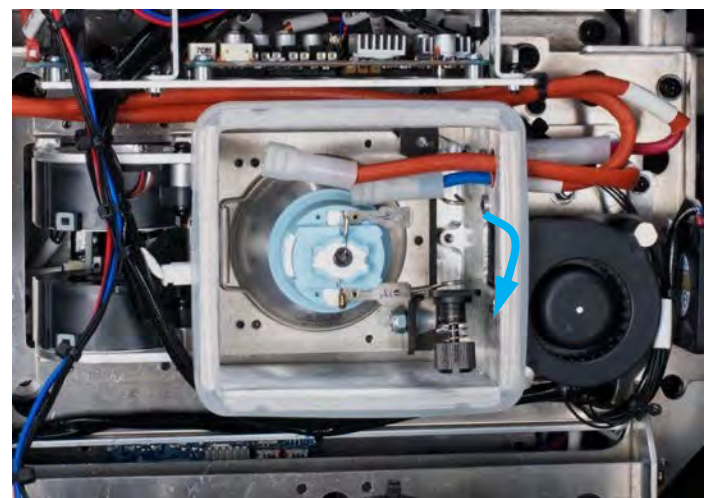
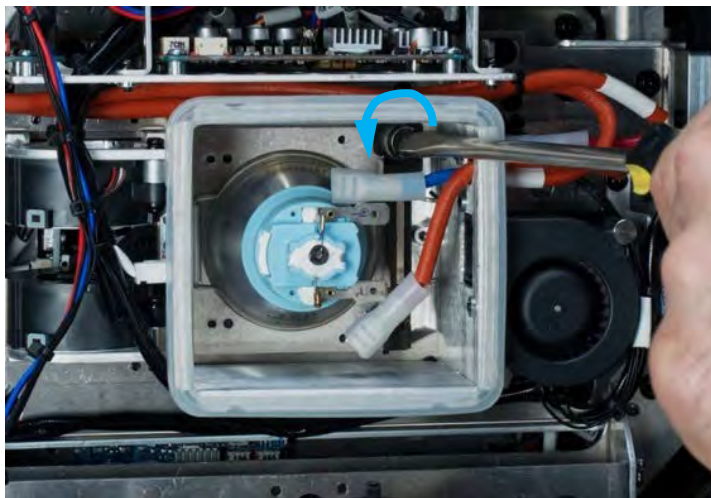

9. Loosen the lamp retaining arm screw and the pull arm out, then unclip the lamp retaining-clip.

LAMP INSTALLATION

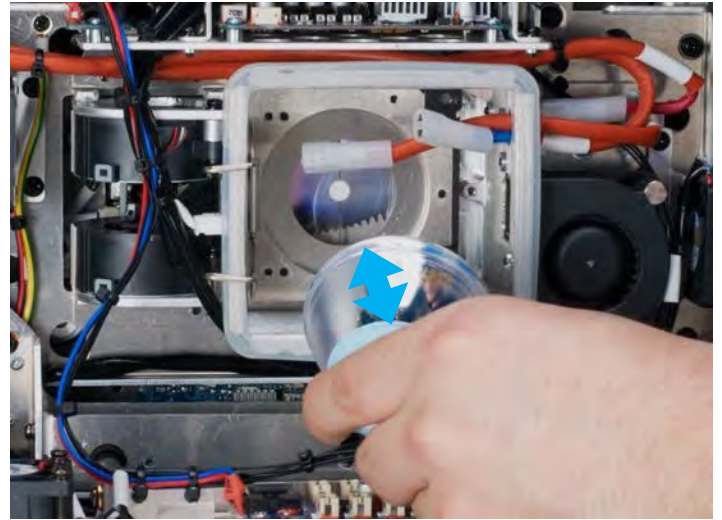
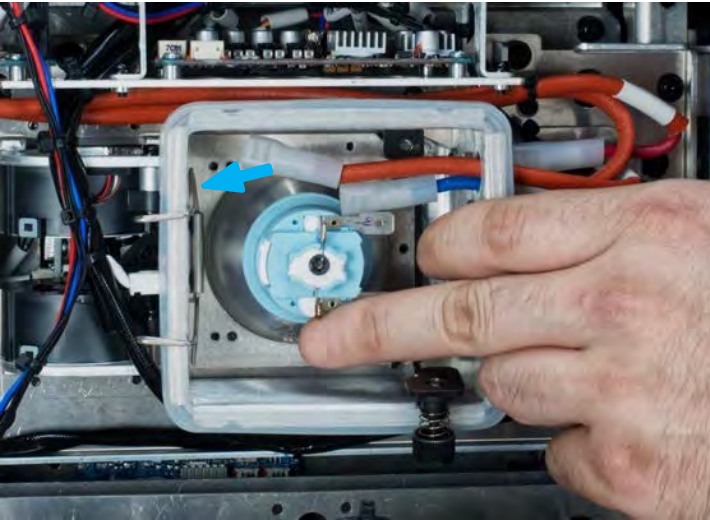

10. Swing the lamp retaining clip out, then carefully remove the lamp.

 **WARNING! LAMP MAY BE HOT. USE CAUTION WHEN TOUCHING LAMP WITH BARE HANDS.**

GASKET INSPECTION



CAREFULLY REMOVE ANY DEBRIS FOUND ON GASKET AND SCREW HOLES OF THE HEATSINK MODULE USING A NONABRASIVE BRUSH BEFORE INSTALLING!

CAREFULLY INSPECT HEATSINK GASKET FOR SIGNS OF WEAR SUCH AS CRACKING OR HARDENING, DEFORMITIES, OR ALIGNMENT ISSUES BEFORE INSTALLING!

ITEMS ABOVE CAN IMPEDE THE IP65 INTEGRITY AND/OR CAUSE INTERNAL DAMAGE. CONTACT ELATION SERVICE REGARDING GASKET REPLACEMENT IF NEEDED.

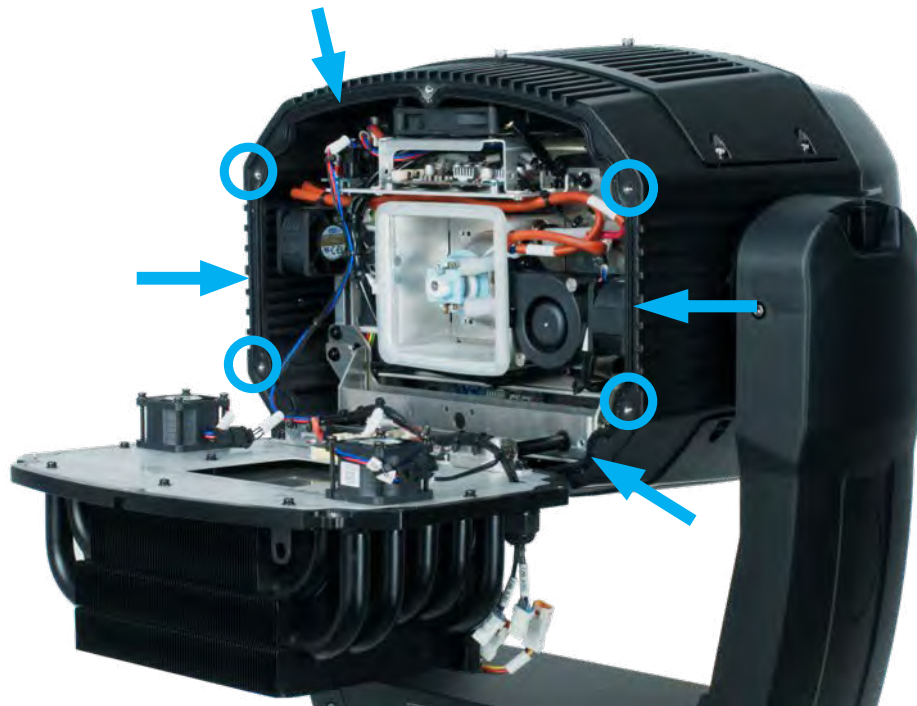

INSTALLATION GUIDELINES



FLAMMABLE MATERIAL WARNING

Keep fixture minimum 5.0 feet (1.5m) away from flammable materials and/or pyrotechnics.



ELECTRICAL CONNECTIONS

A qualified electrician should be used for all electrical connections and/or installations.



USE CAUTION WHEN POWER LINKING OTHER MODEL FIXTURES AS THE POWER CONSUMPTION OF OTHER MODEL FIXTURES MAY EXCEED THE MAX POWER OUTPUT ON THIS FIXTURE. CHECK SILK SCREEN FOR AMX AMPS.



**MINIMUM DISTANCE TO OBJECTS/SURFACES
MUST BE 49.2 FEET (15 METERS)**



**MINIMUM DISTANCE OF INFLAMMABLE MATERIALS
FROM THE SURFACE 1.6 FEET (0.5 METER)**



MAXIMUM TEMPERATURE OF EXTERNAL SURFACE 185° F (85°C)



DO NOT INSTALL THE FIXTURE IF YOU ARE NOT QUALIFIED TO DO SO!

Fixture **MUST** be installed following all local, national, and country commercial electrical and construction codes and regulations.

Before rigging/mounting a single fixture or multiple fixtures to any metal truss/structure or placing the fixture(s) on any surface, a professional equipment installer **MUST** be consulted to determine if the metal truss/structure or surface is properly certified to safely hold the combined weight of the fixture(s), clamps, cables, and accessories.

Overhead rigging requires extensive experience, including amongst others calculating working load limits, installation material being used, and periodic safety inspection of all installation material and the fixture. If you lack these qualifications, do not attempt the installation yourself. Improper installation can result in bodily injury.

Fixture ambient operating temperature range is **14° to 113°F. (-10° to 45°C)**

Do not use the fixture under or above this temperature.

Fixture(s) should be installed in areas outside walking paths, seating areas, or away from areas where unauthorized personnel might reach the fixture by hand.

NEVER stand directly below the fixture(s) when rigging, removing or servicing.

Overhead fixture installation must always be secured with a secondary safety attachment, such as an appropriately rated safety cable.

Allow approximately 15 minutes for the fixture to cool down before serving.

INSTALLATION GUIDELINES

OMEGA BRACKETS INSTALLATION

Insert the Omega Brackets into the matching holes on the bottom of the fixture. Secure the Omega Brackets to the fixture by turning each quick-lock fastener ¼ turn clockwise; making sure the fastener is completely locked. Omega Brackets can be installed into the fixture base as illustrated below.



CLAMP INSTALLATION

When mounting fixture to truss, be sure to secure an appropriately rated professional grade rigging clamp to the included **Omega Brackets** using an M10 screw fitted through the center hole of the **Omega Brackets**. The fixture provides a built-in rigging points for a **SAFETY CABLE**. Be sure to only use one of the designated rigging points for the safety cable and never secure a safety cable to a carrying handle.

RIGGING

Overhead rigging requires extensive experience, including amongst others calculating working load limits, installation material being used, and periodic safety inspection of all installation material and the fixture. If you lack these qualifications, do not attempt the installation yourself. Improper installation can result in bodily injury.



ALWAYS ATTACH AN APPROPRIATELY RATED SAFETY CABLE (NOT INCLUDED) THAT MEETS ALL LOCAL, NATIONAL, AND COUNTRY CODES AND REGULATIONS WHENEVER INSTALLING FIXTURE IN A SUSPENDED ENVIRONMENT!

ART-NET | sACN CONNECTION

When connecting fixture to a network switch to control multiple devices, a **Gigabit Ethernet Switch** that supports **IGMP (Internet Group Management Protocol)** is required. Using a **Gigabit Ethernet Switch** that does not support **IGMP** can cause erratic behavior of all connected devices to the switch. Click link below for more information about IGMP.

https://en.wikipedia.org/wiki/Internet_Group_Management_Protocol

INSTALLATION GUIDELINES

POWER AND DATA CABLES



TO MAINTAIN THE IP65 RATING INTEGRITY OF THE FIXTURE, ALL CABLES MUST BE RUN TOWARDS THE GROUND TO PREVENT WATER ACCUMULATION AROUND THE CONNECTIONS. (see illustration below)

CONTROL PANEL LCD DISPLAY

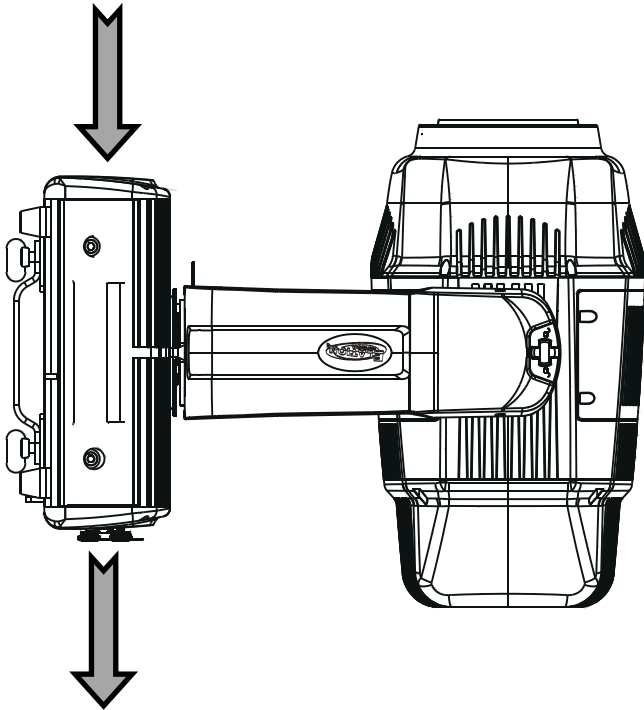

CABLES

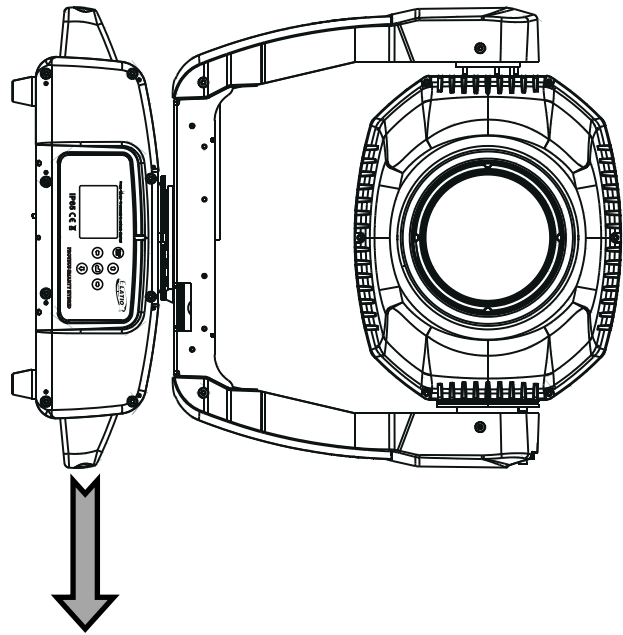

CABLES

INSTALLATION GUIDELINES

POWER AND DATA CONNECTIONS



ENSURE ALL CONNECTIONS AND END CAPS ARE PROPERLY SEALED WITH A DIELECTRIC GREASE (AVAILABLE AT MOST ELECTRICAL SUPPLIERS) TO PREVENT WATER CORROSION AND/OR ELECTRICAL SHORT CIRCUIT.



TO MAINTAIN IP65 RATING INTEGRITY AND PREVENT WATER FROM ENTERING THE FIXTURE, SEAL ALL UNUSED CONNECTION RUBBER CAPS.



SAFETY CABLE RIGGING POINT



ALWAYS ATTACH A SAFETY CABLE WHENEVER INSTALLING THIS DEVICE IN A SUSPENDED ENVIRONMENT TO ENSURE THE FIXTURE WILL NOT DROP IF THE CLAMP FAILS.

INSTALLATION GUIDELINES

RIGGING

Overhead rigging requires extensive experience, including calculating working load limits, knowledge of installation material being used, and periodic safety inspection of all installation material and the fixture itself, among other skills. If you lack these qualifications, do not attempt installation of the fixture on your own. Improper installation can result in bodily injury. The fixture is fully operational in the specific mounting positions illustrated below:

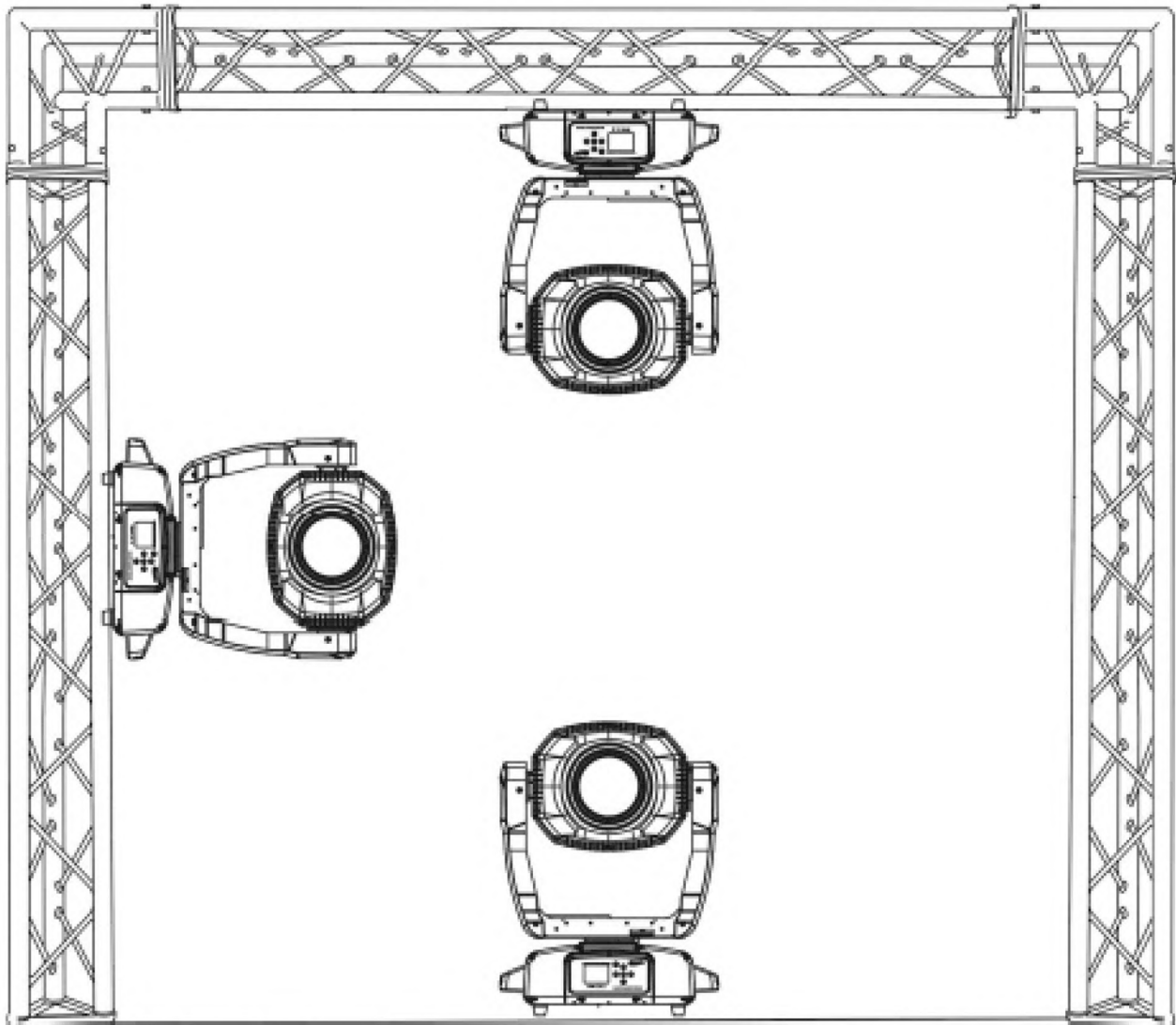

INSTALLATION GUIDELINES

POTENTIAL INTERNAL FIXTURE DAMAGE FROM EXTERNAL SOURCES OF LIGHT BEAMS

External sources of light beams from direct sunlight, lighting moving head fixtures, and lasers, which are focused directly on the exterior housing and/or penetrate the front lens opening of ELATION lighting fixtures, can cause severe internal damage including burning to optics, dichroic color filters, glass and metal gobos, prisms, animation wheels, frost filters, iris, shutters, motors, belts, wiring, discharge lamps, and LEDs.

This issue is not specific only to ELATION lighting fixtures, it is a common issue with lighting fixtures from all manufacturers. Although there is no true way to fully prevent this issue from happening, the guidelines below can prevent any potential damage from occurring if followed. Contact ELATION Service for more details.

DO NOT EXPOSE THE FIXTURE AND/OR FRONT LENS OPENING TO LIGHT BEAMS FROM DIRECT SUNLIGHT, OTHER LIGHTING MOVING HEAD FIXTURES, AND LASERS WHILE UNPACKING, INSTALLATION, USE, AND EXTENDED IDLE TIMES OUTDOORS. DO NOT FOCUS A LIGHT BEAM FROM ONE LIGHTING FIXTURE DIRECTLY TOWARDS ANOTHER.

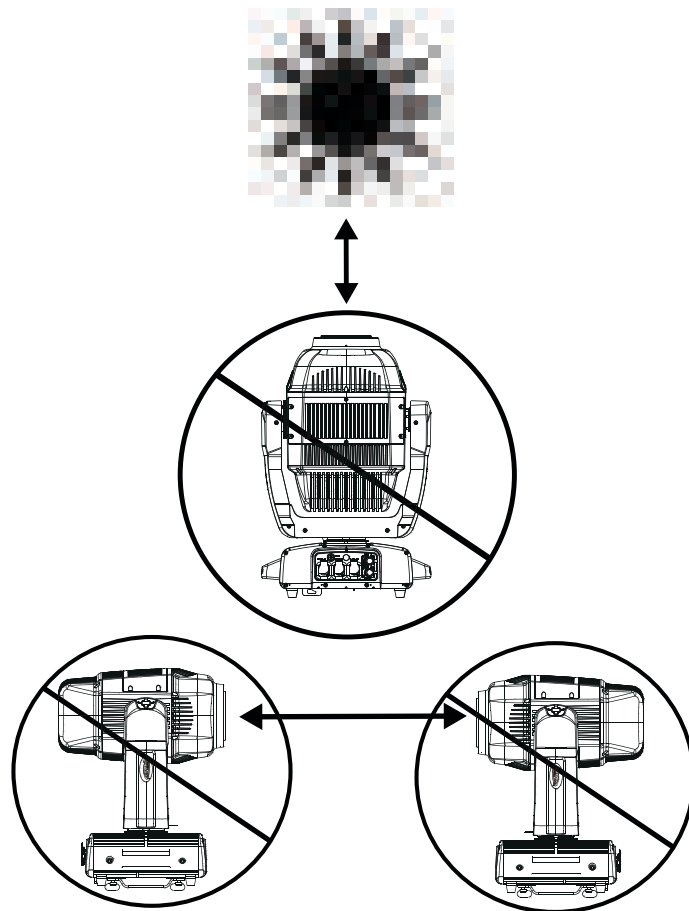

INSTALLATION GUIDELINES

HIBERNATION MODE

This mode disables motors and most electronics in order to reduce wear on the fixture's internal components. The user has the ability to define the period of time that the fixture can remain inactive before it enters hibernation mode. This feature can be accessed by navigating in the main menu to *PERSONALITY > STATUS SETTINGS > HIBERNATION* (see the **System Menu** section of this manual for detailed information). The default setting for hibernation delay time is 15 minutes, but it can be adjusted from 1 min to 99 min, or switched off completely.

Hibernation mode is activated under the following conditions:

- **Loss of DMX signal:** the fixture enters hibernation after the timeout expires. Default is 15 minutes.
- **Remote DMX control:** Press and hold "Hibernate Fixture" for 3s.

Hibernation mode is deactivated under the following conditions:

- **DMX signal is connected.**
- **Remote DMX control:** Hold "Hibernate Off" for 3s.

The fixture will perform a full calibration cycle, then assume the current DMX status.

Please note that the Hibernation does not change the PT position of the fixtures. This allows the user to set the desired position and then issue the Hibernate command.

REMOTE DEVICE MANAGEMENT (RDM)

NOTE: In order for RDM to work properly, RDM enabled equipment must be used throughout the entire system, including DMX data splitters and wireless systems.

Remote Device Management (RDM) is a protocol that sits on top of the DMX512 data standard for lighting, allowing the DMX systems of the fixtures to be modified and monitored remotely. This protocol is ideal for instances in which a unit is installed in a location that is not easily accessible.

With RDM, the DMX512 system becomes bi-directional, allowing a compatible RDM enabled controller to send out a signal to devices on the wire, as well as allowing the fixture to respond (known as a *GET* command). The controller can then use its *SET* command to modify settings that would typically have to be changed or viewed directly via the unit's display screen, including the DMX Address, DMX Channel Mode, and Temperature Sensors.

FIXTURE RDM INFORMATION:

RDM Code	RDM Device ID	Device Model ID	Personality ID
0x61E	Open	1566	Standard (0) Extended (1)

Please be aware that not all RDM devices support all RDM features, and therefore it is important to check beforehand to ensure that the equipment that you are considering includes all of the features that you require.

The following parameters are accessible in RDM on this device:

[0x0200] Sensor Definition
[0x0201] Sensor Value
[0x0080] Device Model Description
[0x0081] Manufacturer Label
[0x0082] Device Label
[0x00E0] DMX Personality
[0x00E1] DMX Personality Description
[0x0400] Device Hours
[0x0600] Pan Invert
[0x0601] Tilt Invert
[0x0500] Display Invert

SYSTEM MENU

The fixture includes an easy to navigate system menu. The control panel (see image below) located on the front of the fixture, provides access to the main system menu and is where all necessary system adjustments are made to the fixture. During normal operation, pressing **MODE/ESC** button once will access the fixture's main menu. Once in the main menu you can navigate through the different functions and access the sub-menus with the **UP, DOWN, RIGHT,** and **LEFT** buttons. Once you reach a field that requires adjusting, press the **ENTER** button to activate that field and use the **UP** and **DOWN** buttons to adjust the field. Pressing the **ENTER** button once more will confirm your setting. You may exit the main menu at any time without making any adjustments by pressing the **MODE/ESC** button.

To access the LCD Menu Control Display via the internal battery, press and hold the **MODE/ESC** button for 10 seconds. The LCD Menu Control Display will shut **OFF** automatically about 1 minute from the last button press.

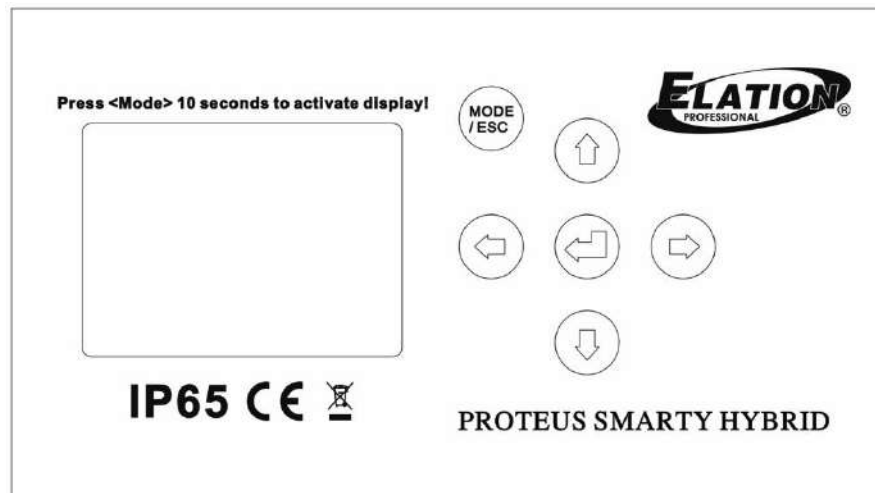

ELATION PROTEUS SMARTY HYBRID SYSTEM MENU - Supports Software Versions: ≥ 1.3.2

Features are subject to change without notice.

*Rotation direction (Clockwise or Counterclockwise) of effects depends on orientation of the fixture head and Pan/Tilt settings.

MAIN MENU	SUB MENU	OPTIONS / VALUES (Default Settings in BOLD)		DESCRIPTION	
FUNCTION	Set Dmx Address	A001~AXXX		DMX Address Setting	
	Dmx Value	PAN.....		DMX Value Display	
	Secondary Mode	Secondary1, Secondary2, Secondary3		Secondary Setting	
	Auto Program	Primary / Alone		Auto Program	
INFORMATION	Time Information	Current Time	xxxx(Hours)	Fixture Run Time From Power ON	
		Total Run Time	xxxx (Hours)	Fixture Total Run Time	
		Last Run Time	xxxx (Hours)	Fixture Last Run Time	
		Lamp Time Info	Total Time xxxx (Hours)	Total Lamp Time Usage	
			Active Time xxxx (Hours)	Active Lamp Time Usage	
			Idle Time xxxx (Hours)	Idle Lamp Time	
			Lamp Life (% Percent)	Lamp Life	
		Lamp Off Time	xxxx (Hours)	Lamp OFF Time	
		LastRun Password	Password= 038	(PSWD Required)	
		Clear Last Run	ON / OFF	Clear Fixture Last Run Time	
	LampTimePassword	Password= 038	(PSWD Required)		
	Clear Lamp Time	ON / OFF	Clear Lamp Run Time		
	Temperature Info	Base Temperature	xxx C° / F°	Temperature in Fixture Base	
		Head Temperature	xxx C° / F°	Temperature in Fixture Head	
		Lamp Temperature	xxx C° / F°	Temperature of Lamp	
	Humidity Info	Head Humidity	xx% RH	Relative Humidity in Head	
		Base Humidity	xx% RH	Relative Humidity in Base	
	Ethernet IP	xxx . xxx . xxx . xxx	xxx . xxx . xxx . xxx	Displays Fixture Ethernet Address	
	Fan Info	Base Fan 1: xxx, ...		Speeds of Head/Base Fans	
	Encode Info	PAN ENCODE: xxxx, TILT ENCODE :xxxx		PAN and TILT Encode Info	
Software Version	Vx.x.x		Software Version		
Error Info	Error Record 1 ~ Error Record 10		Fixture Last 10 Error Codes		
LAMP CONTROL	Lamp On/Off	ON/OFF		Lamp ON/OFF	
	Automatic On	ON/OFF		Lamp ON/OFF when Power ON	
	Lamp On via DMX	ON/OFF		Lamp ON via DMX	
	Lamp Off via DMX	ON/OFF		Lamp OFF via DMX	
	MaxOnAtHumidity	20% - 100%, default = 70%		Fixture Restart at Humidity %	
	Lamp Power Mode	190W, 240W, 280W		Lamp Power Mode	
PERSONALITY	Status Settings	Address via DMX	ON/OFF	Address Via DMX	
		No DMX Status	Close / Hold / Auto / SunProt	Fixture State When NO DMX Signal	
		Pan Reverse	ON/OFF	Pan Reverse Movement	
		Tilt Reverse	ON/OFF	Tilt Reverse Movement	
		Pan Degree	630/540	Pan Degree Select	
		Feedback	ON/OFF	Movement Feedback	
		Hibernation	OFF, 01M~99M, 15M	Stand By Mode	
	Service Setting	Password	Password= 050		Service Password
		Clear Err. Info	ON/OFF		Clear Error Info (PSWD Required)
		DFLT Pow. LampOn	ON/OFF		Set Lamp Default Power State to ON
	Display Setting	Shutoff Time	02~60m 05m		Display Shut Off Time
		Display Reverse	AUTO, ON, OFF		Display Reverse 180°
		Key Lock	ON/OFF		Key Lock
	Temperature C/F	Celsius/Fahrenheit		Temperature Switch Between C°/ F°	
	Initial Status	PAN =XXX, ...		Initial Effect Position	
	Select Signal	DMX Only, Art-Net, sACN		Activate DMX, Art-Net, or sACN	
	Ethernet IP	XXX . XXX . XXX . XXX		Ethernet IP	
	Ether Mask IP	XXX . XXX . XXX . XXX		Ethernet Mask IP	
	Set Universe	000 - 32767		Set Art-Net Universe	
	DHCP	On / Off		Auto assign IP address	
Reset Default	ON/OFF	Password= 011	Restore Factory Settings (PSWD Required)		

ELATION SMARTY HYBRID SYSTEM MENU - Supports Software Versions: ≥ 1.1.3

Features subject to change without notice.

*Rotation direction (Clockwise or Counterclockwise) of effects depends on orientation of the fixture head and Pan/Tilt settings.

MAIN MENU	SUB MENU	OPTIONS / VALUES (Default Settings in BOLD)		DESCRIPTION	
Reset Function	Reset All			Reset All Motors	
	Reset Pan&Tilt			Reset Pan/Tilt	
	Reset Colors			Reset Color Wheel	
	Reset Gobos			Reset Gobos	
	Reset Shutter			Reset Shutter	
	Reset Others			Reset Other Motors	
Effect Adjust	Test Channel	PAN		Test function	
	Manual Control	PAN =XXX,		Fine Adjustments	
	Calibration	Calibration Password		Password 050 (PSWD Required)	
Pan=XXX, ...					
User Mode Set	User Mode	Standard Mode		DMX Channel Modes	
		Extended Mode			
Edit Program	Select Program	Auto Pro Part1 = Program 1~10 (Program 1)		Select Programs To Be Run	
		Auto Pro Part2 = Program 1~10 (Program 2)			
		Auto Pro Part3 = Program 1~10 (Program 3)			
	Edit Program	Program 1	Program Test		Testing Program
		:	Step 01=SCxxx		Program In Loop
		Program 10	Step 64=SCxxx		Save and Exit
	Edit Scenes	Edit Scene 001 ~ Edit Scene 250	Pan,Tilt,.....		Save and Automatically Return
			--FadeTime-- --Scene Time--		Manual Scenes Edit
			Input By Outside		Stores Scenes via Ext DMX Console
Rec. Controller	XX~XX		Automatic Scenes Recorder		

Please note: An Elation E-Loader III can be used to update the fixture to the latest software. To order this device, please contact Elation support for further details.

SYSTEM MENU

PERSONALITY - Status Settings - Address Via DMX

When ON, define the desired DMX address via an external controller.

NOTE: This process assumes the fixture DMX address is set to 001. If fixture DMX address is not at 001, you must adjust the channel numbers accordingly in order for this feature to work.

For example: if your fixture address is 010, then Channel 1 becomes Channel 10, Channel 2 becomes Channel 11, and Channel 3 becomes Channel 12.

1. Connect the fixture to the external controller and power ON.
2. Set the DMX value of **Channel 1** on the controller to **(7)**.
3. Set the DMX value of **Channel 2** on the controller to **(7)** or **(8)**.
When set to **(7)**, the DMX address can be set between **(1)** and **(255)**.
When set to **(8)**, the DMX address can be set between **(256)** and **(511)**.
4. Using **Channel 3** on the controller set the desired DMX address of the fixture.

Example 1: If the desired DMX address is **57**, set **Channel 1** to a value of **(7)**, set **Channel 2** to a value of **(7)**, and then set **Channel 3** to a value of **(57)**.

Example 2: If the desired DMX address is **420**, set **Channel 1** to a value of **(7)**, set **Channel 2** to a value of **(8)**, and then set **Channel 3** to a value of **(164)**. ($256+164=420$)

5. After setting **Channel 3** to the desired DMX address value, wait for approximately 20 seconds (some fixtures may require a longer time) for the fixture to complete the address reset function.

PERSONALITY – Service Setting - Password (050)

The Service Password MUST be entered in order to access the service menus.

SYSTEM MENU

PERSONALITY - Display Setting – Key Lock

When ON, Control Panel buttons lock automatically after exiting main menu for 15 seconds. To unlock, keep **MODE/ESC** button pressed for 3 seconds.

PERSONALITY - Reset Default



ONLY QUALIFIED TECHNICIANS SHOULD PERFORM THIS FUNCTION!

This function restores all fixture settings to the factory default settings. The password is **011** and must be entered each time a reset is performed.

EFFECT ADJUST – Test Channel

Auto test each individual channel function independently from the DMX control board.

EFFECT ADJUST – Manual Control

Select and manually test and fine adjust each individual channel function independently from DMX control board. This function will center PAN and TILT motors and set dimmer to 100%. PAN and TILT functions will still operate if the fixture needs to be positioned to a flat clear surface. With the individual functions, you can focus the light on a flat surface (wall) and perform fine adjustments.

EFFECT ADJUST – Calibration



ONLY QUALIFIED TECHNICIANS SHOULD PERFORM THIS FUNCTION!

This function allows small adjustments to be made to the Pan, Tilt, and Zoom movements to compensate for wear or in the event a sensor has been knocked slightly out of place. Because improper use of this function can result in undesired operation this function has been password protected. The password is **050** and must be entered each time the calibration menu function is entered. Because calibration is an extremely delicate procedure, instructions on performing this action are left out of this manual. For a first-time calibrator, please contact our customer support team for step-by-step instructions.

SYSTEM MENU

EDIT PROGRAM – Rec. Controller

The fixture features an integrated DMX-recorder by which you can transmit the programmed scenes from your DMX-controller to the moving head. Adjust the desired scene numbers via the encoder (from – to). When you call up the scenes at your controller, they will automatically be transmitted to the moving head.

EDIT PROGRAM – Record Controller – Working with Built-In Programs

A Primary unit can send up to 3 different data groups to the Secondary units, i.e. a Primary unit can start 3 different Secondary units, which run 3 different programs. The Primary unit sends the 3 program parts in a continuous loop.

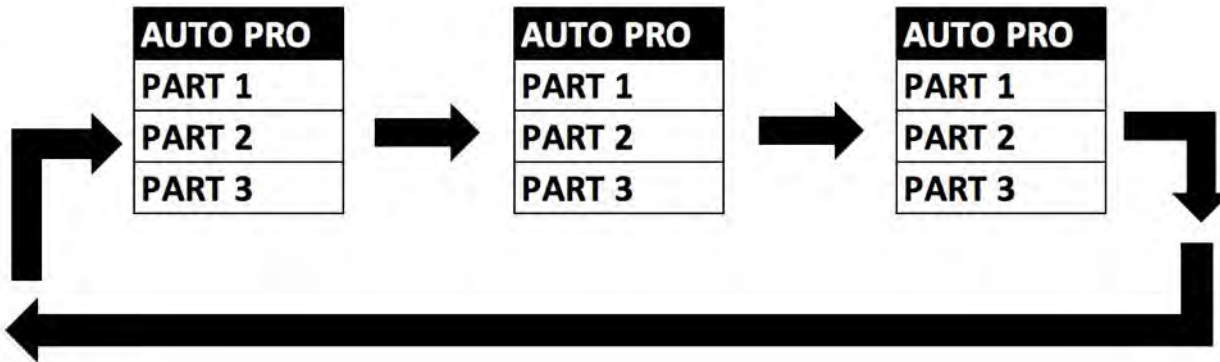

The Secondary unit receives data from the Primary unit according to the group which the Secondary unit was assigned to. If e.g. a Secondary unit is set to “**Secondary 1**” in the menu “**Set to Secondary**”, the Primary unit sends “**Auto Program Part 1**” to the Secondary unit.

If set to “**Secondary 2**”, the Secondary unit receives “**Auto Program Part 2**”.

SYSTEM MENU

EDIT PROGRAM – Record Controller – Working with Built-In Program [continued]

To start an Auto Program, proceed as follows:

1. Secondary Setting

Select “**Function Mode**”.

Press **ENTER** to confirm.

Select “**Set to Secondary**”.

Press **ENTER** to confirm.

Select “**Secondary 1**”, “**Secondary 2**” or “**Secondary 3**”.

Press **ENTER** to confirm.

Press **MODE/ESC** in order to return to the main menu.

2. Automatic Program Run

Select “**Function Mode**”.

Press **ENTER** to confirm.

Select “**Auto Program**”.

Press **ENTER** to confirm.

Select “**Primary**” or “**Alone**”.

Press **ENTER** to confirm.

Press **MODE/ESC** in order to return to the main menu.

3. Program Selection for Auto Pro Part

Select “**Edit Program**”.

Press **ENTER** to confirm.

Select “**Select Programs**”.

Press **ENTER** to confirm.

Select “**Auto Pro Part 1**”, “**Auto Pro Part 2**” or “**Auto Pro Part 3**” and select which Secondary program is to be sent. Selection “**Part 1**” means, that the Secondary unit runs the same program as the primary units.

Press **ENTER** to confirm.

Press **MODE/ESC** in order to return to the main menu.

4. Program Selection for Edit Program

Select “**Edit Program**”.

Press **ENTER** to confirm.

Select “**Edit Program**”.

Press **ENTER** to confirm.

Select the desired program to edit specific scenes into a specific program.

Press **ENTER** to confirm.

Press **MODE/ESC** in order to return to the main menu.

SYSTEM MENU

EDIT PROGRAM – Record Controller – Working with Built-In Program [continued]

5. Automatic Scene Recording

Select “**Edit Program**”.

Press **ENTER** to confirm.

Select “**Edit Scenes**”.

Select desired scene numbers. A maximum of 250 scenes can be programmed.

Press **ENTER** to confirm.

Press **MODE/ESC** in order to return to the main menu.

Example:

Program 2 includes scenes: 10, 11, 12, & 13

Program 4 includes scenes: 8, 9, & 10

Program 6 includes scenes: 12, 13, 14, & 15

Auto Pro Part 1 is Program 2

Auto Pro Part 2 is Program 3

Auto Pro Part 3 is Program 6

The 3 Secondary groups run the Auto Program in certain time segments. (See chart below)

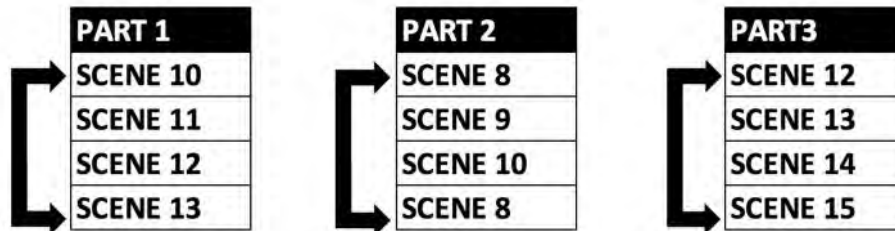

DMX CHANNEL FUNCTIONS AND VALUES

RELATION PROTEUS SMARTY HYBRID™			
DMX Channel Values / Functions (34 DMX Channels)			
Supports Software Versions: ≥ 1.3.2			
Features are subject to change without any prior written notice.			
*Rotation direction (Clockwise or Counterclockwise) of effects depends on orientation of the fixture head and Pan/Tilt settings.			
MODE / CHANNEL		VALUE	FUNCTION
STANDARD	EXTENDED		
1	1		PAN MOVEMENT
		0-255	PAN Movement
2	2		PAN FINE MOVEMENT FINE
		0-255	Fine 16-bit Control of PAN Movement
3	3		TILT MOVEMENT
		0-255	TILT Movement
4	4		TILT MOVEMENT FINE
		0-255	Fine 16-bit Control of TILT Movement
5	5		CYAN COLOR
		0-255	0-WHITE ~ 255-100% CYAN
	6		CYAN COLOR FINE
		0-255	CYAN FINE 16-bit Adjustment
6	7		MAGENTA COLOR
		0-255	0-WHITE ~ 255-100% MAGENTA
	8		MAGENTA COLOR FINE
		0-255	MAGENTA FINE 16-bit Adjustment
7	9		YELLOW COLOR
		0-255	0-WHITE ~ 255-100% YELLOW
	10		YELLOW COLOR FINE
		0-255	YELLOW FINE 16-bit Adjustment

MODE / CHANNEL		VALUE	FUNCTION
STANDARD	EXTENDED		
8	11		COLOR WHEEL
		0-10	OPEN / WHITE
		11-19	RED - [RGB = 255, 0, 0]
		20-28	GREEN - [RGB = 0, 255, 0]
		29-37	YELLOW - [RGB = 255, 255, 0]
		38-46	MAGENTA - [RGB = 255, 0, 255]
		47-55	ORANGE - [RGB = 255, 102, 0]
		56-64	AQUA - [RGB = 10, 148, 22]
		65-73	PINK - [RGB = 217, 89, 153]
		74-82	CYAN - [RGB = 53, 227, 227]
		83-91	QUAD COLOR [R=163,8,8] [Y=242, 242,5] [B=11,71,212] [G=33,181,57]
		92-100	CTB - [RGB = 134, 165, 227]
		101-109	UV - [RGB = 70, 19, 173]
		110-118	CTO - [RGB = 209, 154, 92]
		119-127	BLUE - [RGB = 0, 51, 255]
		128-189	Clockwise Color Rotation from FAST to SLOW
		190-193	NO Rotation
		194-255	Counter Clockwise Color Rotation from SLOW to FAST
	12		COLOR WHEEL FINE ADJUSTMENT
		0-255	FINE 16-bit Adjustment of Color Wheel to Any Position

MODE / CHANNEL		VALUE	FUNCTION
STANDARD	EXTENDED		
9	13		ROTATING GOBOS, CONTINUOUS ROTATION [WHEEL 1]
		0-10	BEAM OPEN
		11-21	SPOT OPEN
		22-31	Rotate Gobo 1
		32-41	Rotate Gobo 2
		42-51	Rotate Gobo 3
		52-61	Rotate Gobo 4
		62-71	Rotate Gobo 5
		72-81	Rotate Gobo 6
		82-91	Rotate Gobo 7
		92-101	Rotate Gobo 8
		102-112	Shake SLOW to FAST Gobo 1
		113-123	Shake SLOW to FAST Gobo 2
		124-134	Shake SLOW to FAST Gobo 3
		135-145	Shake SLOW to FAST Gobo 4
		146-156	Shake SLOW to FAST Gobo 5
		157-167	Shake SLOW to FAST Gobo 6
		168-178	Shake SLOW to FAST Gobo 7
		179-189	Shake SLOW to FAST Gobo 8
		190-221	Clockwise Gobo Wheel Rotation from FAST to SLOW
		222-223	RESERVED
224-255	Counter Clockwise Gobo Wheel Rotation from SLOW to FAST		
10	14		ROTATING GOBOS, INDEX ROTATION [WHEEL 1]
		0-127	Gobo Indexing
		128-189	Clockwise Gobo Rotation from FAST TO SLOW
		190-193	NO Rotation
		194-255	Counter Clockwise Gobo Rotation from SLOW to FAST
	15		ROTATING GOBOS, FINE INDEX ROTATION [WHEEL 1]
		0-255	Gobo Rotation FINE 16-bit Indexing

MODE / CHANNEL		VALUE	FUNCTION
STANDARD	EXTENDED		
11	16		STATIC / FIXED GOBOS [GOBO WHEEL 2]
		0-9	OPEN
		10-17	Static / Fixed Gobo 1
		18-25	Static / Fixed Gobo 2
		26-33	Static / Fixed Gobo 3
		34-41	Static / Fixed Gobo 4
		42-49	Static / Fixed Gobo 5
		50-57	Static / Fixed Gobo 6
		58-65	Static / Fixed Gobo 7
		66-73	Static / Fixed Gobo 8
		74-81	Static / Fixed Gobo 9
		82-89	Static / Fixed Gobo 10
		90-97	Static / Fixed Gobo 11
		98-105	Static / Fixed Gobo 12
		106-112	Shake SLOW to FAST Gobo 1
		113-119	Shake SLOW to FAST Gobo 2
		120-126	Shake SLOW to FAST Gobo 3
		127-133	Shake SLOW to FAST Gobo 4
		134-140	Shake SLOW to FAST Gobo 5
		141-147	Shake SLOW to FAST Gobo 6
		148-154	Shake SLOW to FAST Gobo 7
		155-161	Shake SLOW to FAST Gobo 8
		162-168	Shake SLOW to FAST Gobo 9
		169-175	Shake SLOW to FAST Gobo 10
		176-182	Shake SLOW to FAST Gobo 11
		183-189	Shake SLOW to FAST Gobo 12
		190-221	Clockwise Gobo Wheel Rotation from FAST to SLOW
222-223	RESERVED		
224-255	Counter Clockwise Gobo Wheel Rotation from SLOW to FAST		
	17		STATIC / FIXED GOBOS, FINE INDEX ROTATION [WHEEL 2]
		0-255	Gobo Rotation FINE 16-bit Indexing

MODE / CHANNEL		VALUE	FUNCTION
STANDARD	EXTENDED		
12	18		ROTATING PRISMS, PRISM / GOBO MACROS
		0-31	OPEN
		32-64	16-Facet PRISM
		65- 94	4-Facet Linear PRISM
		95- 127	16 + 4 Facet PRISMS COMBINED
		128-135	Prism / Gobo Macro 1
		136-143	Prism / Gobo Macro 2
		144-151	Prism / Gobo Macro 3
		152-159	Prism / Gobo Macro 4
		160-167	Prism / Gobo Macro 5
		168-175	Prism / Gobo Macro 6
		176-183	Prism / Gobo Macro 7
		184-191	Prism / Gobo Macro 8
		192-199	Prism / Gobo Macro 9
		200-207	Prism / Gobo Macro 10
		208-215	Prism / Gobo Macro 11
		216-223	Prism / Gobo Macro 12
224-231	Prism / Gobo Macro 13		
232-239	Prism / Gobo Macro 14		
240-247	Prism / Gobo Macro 15		
248-255	Prism / Gobo Macro 16		
13	19		ROTATING PRISMS, PRISMS INDEX ROTATION
		0-127	Prism Indexing
		128-189	Clockwise Prism Rotation from FAST to SLOW
		190-193	NO Rotation
		194-255	Counter Clockwise Prism Rotation from SLOW to FAST
	20		ROTATING PRISMS, PRISMS FINE INDEX ROTATION
		0-255	Gobo Rotation FINE 16-bit Indexing
14	21		FOCUS
		0-255	Continuous Adjustment from NEAR to FAR
	22		FOCUS FINE
		0-255	Continuous FINE 16-Bit Focus Adjustment

MODE / CHANNEL		VALUE	FUNCTION
STANDARD	EXTENDED		
15	23		ZOOM
		0-255	ZOOM Adjustment from SMALL to BIG
	24		ZOOM FINE
		0-255	ZOOM FINE 16-bit Adjustment
	25		AUTO FOCUS
			SPOT MODE
		0-31	AUTO FOCUS OFF
		32-59	26.2 ft (8m)
		60-87	29.5 ft (9m)
		88-115	32.8 ft (10m)
		116-143	36.0 ft (11m)
		144-171	39.4 ft (12m)
		172-199	42.7 ft (13m)
		200-227	46.0 ft (14m)
		228-255	49.2 ft (15m)
			BEAM MODE
		0-21	AUTO FOCUS OFF
		22-39	26.2 ft (8m)
		40-57	29.5 ft (9m)
		58-75	32.8 ft (10m)
		76-93	36.0 ft (11m)
		94-111	39.4 ft (12m)
		112-129	42.7 ft (13m)
		130-147	46.0 ft (14m)
		148-165	49.2 ft (15m)
		166-183	52.5 ft (16m)
		184-201	55.8 ft (17m)
		202-219	59.0 ft (18m)
		220-237	62.3 ft (19m)
238-255	65.6 ft (20m)		
	26		AUTO FOCUS FINE
		0-255	Continuous FINE 16-bit Focus Adjustment

MODE / CHANNEL		VALUE	FUNCTION
STANDARD	EXTENDED		
16	27		SHUTTER, STROBE
		0-31	Shutter CLOSED
		32-63	NO Function (Shutter OPEN)
		64-95	Strobe Effect SLOW to FAST
		96-127	NO Function (Shutter OPEN)
		128-159	Pulse Effect In Sequences
		160-191	NO Function (Shutter OPEN)
		192-223	Random Strobe Effect SLOW to FAST
		224-255	NO Function (Shutter OPEN)
17	28		DIMMER INTENSITY
		0-255	Intensity 0 to 100%
18	29		DIMMER INTENSITY FINE
		0-255	Intensity FINE 16-bit Adjustment 0 to 100%
19	30		FROST
		0-127	DISABLE FROST
		128-255	ENABLE FROST
	31		GOBO / CMY / COLOR MACRO SPEED
		0-255	MAX to MIN Speed

MODE / CHANNEL		VALUE	FUNCTION
STANDARD	EXTENDED		
			CMY / COLOR MACROS
		0-31	OFF
		32-39	Macro 1
		40-47	Macro 2
		48-55	Macro 3
		56-63	Macro 4
		64-71	Macro 5
		72-79	Macro 6
		80-87	Macro 7
		88-95	Macro 8
		96-103	Macro 9
		104-111	Macro 10
		112-119	Macro 11
		120-127	Macro 12
	32	128-135	Macro 13
		136-143	Macro 14
		144-151	Macro 15
		152-159	Macro 16
		160-167	Macro 17
		168-175	Macro 18
		176-183	Macro 19
		184-191	Macro 20
		192-199	Macro 21
		200-207	Macro 22
		208-215	Macro 23
		216-223	Macro 24
		224-231	Macro 25
		232-239	Macro 26
		240-247	Macro 27
		248-255	RANDOM CMY
			PAN / TILT MOVEMENT SPEED
		0-225	MAX to MIN Speed
	33	226-235	Blackout by PAN/TILT Movement
		236-245	Blackout by ALL WHEEL Movement
		246-255	NO FUNCTION

MODE / CHANNEL		VALUE	FUNCTION
STANDARD	EXTENDED		
20	34		LAMP ON/OFF, RESET, INTERNAL PROGRAMS
		0-19	COLOR Change Normal
		20-29	COLOR Change to Any Position
		30-39	RESERVED
		40-49	LAMP ON
		50-59	LAMP OFF
		60-66	LAMP POWER 190W
		67-73	LAMP POWER 240W
		74-79	LAMP POWER 280W
		80-84	All MOTORS Reset
		85-87	Scan Motor Reset
		88-90	COLOR Reset
		91-93	GOBO Reset
		94-96	SHUTTER & DIMMER Reset
		97-99	OTHER MOTORS Reset
		100-119	INTERNAL PROGRAM 1
		120-139	INTERNAL PROGRAM 2
		140-159	INTERNAL PROGRAM 3
		160-179	INTERNAL PROGRAM 4
		180-199	INTERNAL PROGRAM 5
		200-219	INTERNAL PROGRAM 6
		220-239	INTERNAL PROGRAM 7
		240-241	Hibernation Off
		242-243	Hibernation On
		244-246	Home Position Before Power Off
		247-249	Home Position Off
		250-251	Display Off
		252-253	Display On
254-255	Reserved		

ERROR CODES

When power is applied, the unit will automatically enter a “Reset/Test” mode. This mode brings all the internal motors to a home position. If there is an internal problem with one or more of the motors an error code will flash in the display in the form of “XXEr” where as XX will represent a function number. For example, when the display shows “0Er” it means there is some type of error with the Pan motor. If there are multiple errors during the start-up process they will all flash in the display. For example: if the fixtures has errors on **Channel 1, 2, and 5** all at the same time, you will see the error message “01Er”, “02Er”, and ”05Er” flash repeated 5 times.

If an error does occur during the initial start-up procedure the fixture will self-generate a second reset signal and try to realign all the motors and correct the errors. If the error persists after a second attempt a third attempt will be made. If after a third attempt all the errors have not been corrected the fixture will make the following determinations:

3 or More Errors - The fixture cannot function properly with three or more errors therefore the fixture will place itself in a stand-by mode until subsequent repairs can be made.

Less Than 3 Errors - The fixture has less than 3 errors; therefore, most other functions will work properly. The fixture will attempt to operate normally until the errors can be correct by a technician. The errors in question will remain flashing in the display as a reminder of internal errors.

Error Codes subject to change without notice.	
ERROR CODES	DESCRIPTION
PAN Er	Movement is not located in the default position after the reset. This message will appear after a fixture reset if the magnetic-indexing circuit malfunctions (sensor failed, or magnet is missing) or there is a motor failure (defective motor or a defective motor IC drive on the main PCB). This error may also be displayed if the head/yoke was blocked during a reset function.
TILT Er	
Cyan Color Wheel Er	
Magenta Color Wheel Er	
Yellow Color Wheel Er	
Color Wheel Er	
Gobo Wheel 1 Er	
Gobo Rotation Wheel 1 Er	
Dimmer Wheel Er	
Fixed Gobo Wheel Er	
Prim 3 Wheel Er	
Prism Rotation 1 Wheel Er	
Prism 16 Wheel Er	
Focus Wheel Er	
Zoom Wheel Er	
Frost Wheel Er	

SPECIFICATIONS

SOURCE

Philips™ MSD Platinum 200 Flex 280W Lamp

Up To 6,000 Hour Lamp Life*

*Test lab conditions. May vary depending on several factors including but not limited to:

Environmental Conditions, Power/Voltage, Usage Patterns (On-Off Cycling), Control, Dimming, and Lamp Mode.

PHOTOMETRIC DATA

11,000 Total Output Lumen

128,426 LUX 11,931 FC @49.2' (15m) (Min Zoom Beam)

135,108 LUX 12,552 FC @16.4' (5m) (Min Zoom Spot)

Beam

Zoom Range 1° - 18°

Beam Angle 1.1° - 7°

Field Angle 2.6° - 17.8°

Spot

Zoom Range 3° - 27°

Beam Angle 1.8° - 18.7°

Field Angle 2.8° - 28.8°

Wash

Zoom Range 5° - 33°

Beam Angle 2.6° - 24.9°

Field Angle 4.6° - 40.7°

EFFECTS

Beam, Spot, Wash Modes

Motorized Zoom 1° - 18° Beam, 3° - 27° Spot, 5° - 33° Wash

Full Frost Filter for Wash Effects

16-Facet and 4-Facet Linear Prisms

CMY Color, Gobo, Prism Macros

Motorized Focus with Auto-Focus Feature

High Speed Shutter and Strobe

Pan Angle: 540°/630°

Tilt Angle: 262°

COLOR

Full CMY Color Mixing System

13 Colors including Quad Color, CTO, CTB, and UV

GOBOS

2 Gobo Wheels

8 Rotating / Indexing Interchangeable Glass Gobos

12 Static-Stamped Metal Gobos

CONTROL / CONNECTIONS

2 DMX Channel Modes (20 / 34)

DMX, RDM, Art-NET, sACN Protocol Support

(6) Button Touch Control Panel

Full Color 180° Reversible LCD Menu Display

IP65 5pin XLR DMX In/Out

IP65 RJ45 ethernet In/Out

IP65 Locking Power Cable In

With Wired Digital Communication Network

SIZE / WEIGHT

Length: 17.51 in (445mm)

Width: 18.06 in (459mm)

Height: 26.96 in (685mm)

Center Spacing: 21.69 in (551mm)

Weight: 78.26 lbs. (35.5kg)

ELECTRICAL / THERMAL

AC 100-240V 50/60Hz

Max Power Consumption 500W

BTU/hr (+/- 10%) 1705

APPROVALS / RATINGS

CE | cETLus | IP65

Specifications and improvements in the design of this unit and this manual are subject to change without notice.

DIMENSIONAL DRAWINGS

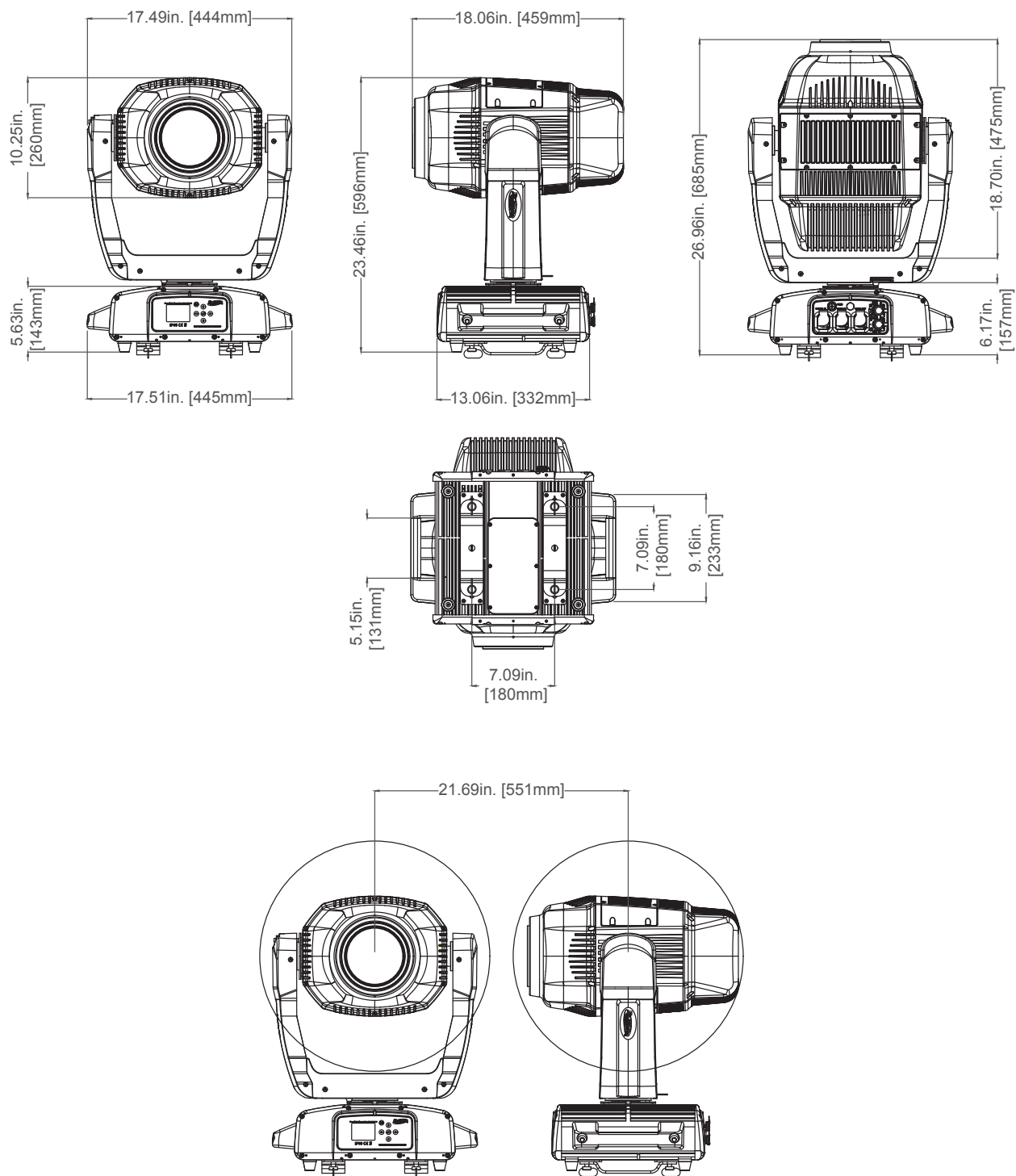

Specifications and improvements in the design of this unit and this manual are subject to change without notice.

DIMENSIONAL DRAWINGS – FOAM INLAY

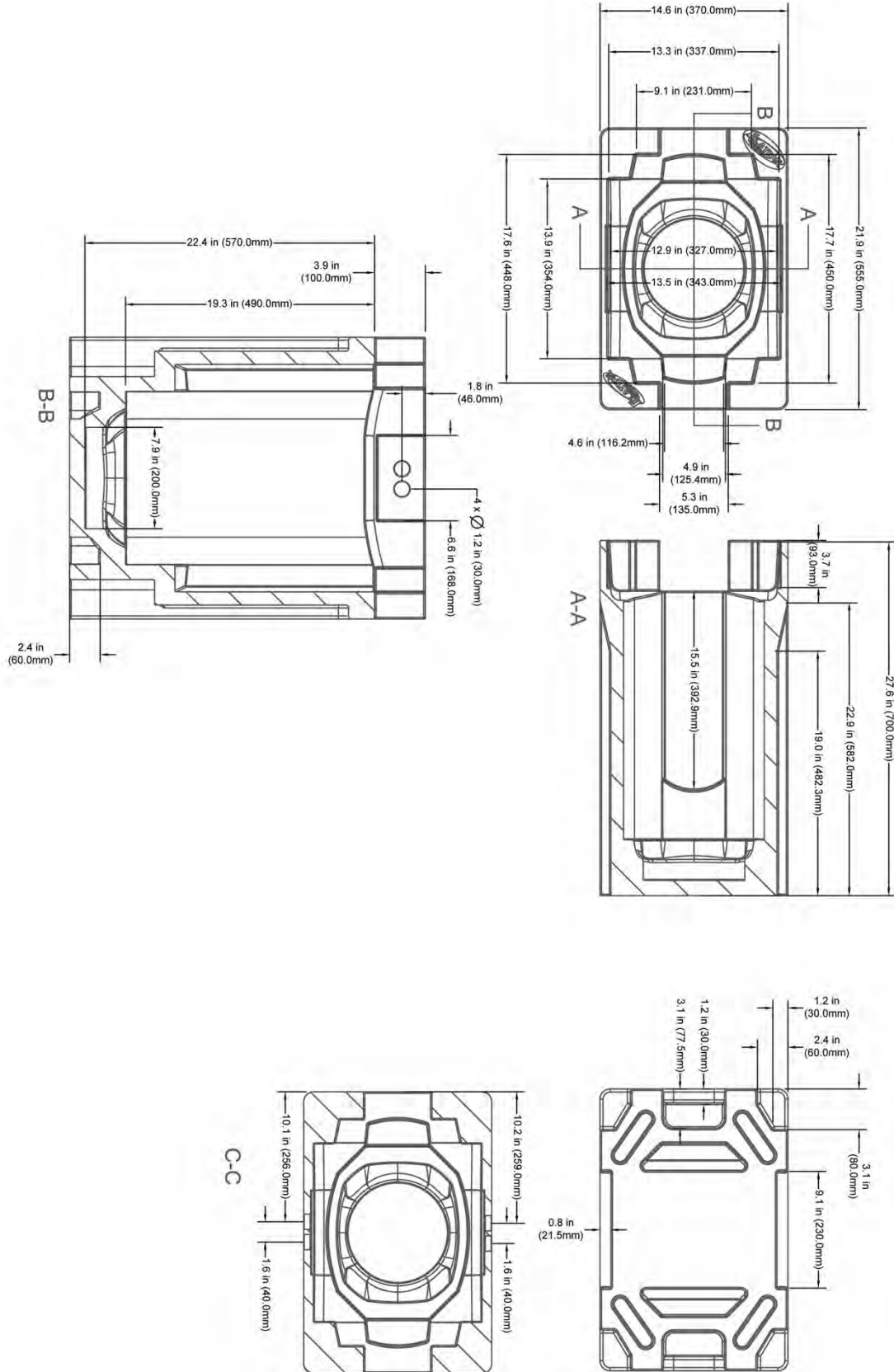

OPTIONAL ACCESSORIES

ORDER CODE	ITEM
IP TESTER	IP Fixture Vacuum and Pressure Leak Tester
TRIGGER CLAMP	Heavy Duty Wrap Around Hook Style Clamp
STR527	5 ft. (1.5m) IP65 5pin XLR Cable
CAT628	5 ft. (1.5m) IP65 CAT6 Ethernet Cable
	Additional Cable Lengths Available

FCC STATEMENT

This device complies with Part 15 of the FCC Rules. Operation is subject to the following two conditions: (1) this device may not cause harmful interference, and (2) this device must accept any interference received, including interference that may cause undesired operation.

FCC RADIO FREQUENCY INTERFERENCE WARNINGS & INSTRUCTIONS

This product has been tested and found to comply with the limits as per Part 15 of the FCC Rules. These limits are designed to provide reasonable protection against harmful interference in a residential installation. This device uses and can radiate radio frequency energy and, if not installed and used in accordance with the included instructions, may cause harmful interference to radio communications. However, there is no guarantee that interference will not occur in a particular installation. If this device does cause harmful interference to radio or television reception, which can be determined by turning the device off and on, the user is encouraged to try to correct the interference by one or more of the following methods:

- Reorient or relocate the device.
- Increase the separation between the device and the receiver.
- Connect the device to an electrical outlet on a circuit different from which the radio receiver is connected.
- Consult the dealer or an experienced radio/TV technician for help.

Europe Energy Saving Notice

Energy Saving Matters (EuP 2009/125/EC)

Saving electric energy is a key to help protecting the environment. Please turn off all electrical products when they are not in use. To avoid power consumption in idle mode, disconnect all electrical equipment from power when not in use. Thank you.



This page intentionally left blank.

