

# Beta Microphones

EXPERT SOUND, IN EVERY DETAIL.

For over two decades, Beta microphones have been the choice of top touring and recording professionals for capturing fine details in demanding acoustic environments. Each specialised model is precision-engineered for focused, accurate reproduction of the intended source. Recognised for their superior construction, low handling noise and high gain-before-feedback, Beta microphones redefine sensitivity and control for essential, expert sound reinforcement.

#### FIELD OF APPLICATION

Professional Live Performance

Touring

Recording Applications

#### PRODUCT-HIGHLIGHTS

Superior sound quality with fine details

Maximum durability

Maximum isolation from undesired sound sources

Minimum off-axis sound for higher gain-before-feedback

Advanced shock mount



# Beta 58A Dynamic Vocal Microphone (Supercardioid)

## Overview

The Beta 58A is the leading choice among vocalists and touring professionals worldwide. Featuring a smooth, present sound and wide frequency response, its supercardioid polar pattern provides maximum sound isolation and minimum off-axis tone colouration.

## Features

- Uniform supercardioid pattern for high gain-before-feedback and superior rejection of off-axis sound
- Minimally affected by varying load impedance
- Neodymium magnet for high signal-to-noise output
- Advanced pneumatic shock-mount system that minimises transmission of mechanical noise and vibration
- Hardened steel mesh grille that resists wear and abuse

## Specifications

<b>Type</b>	Dynamic
<b>Frequency Response</b>	50 Hz to 16 kHz
<b>Polar Pattern</b>	Supercardioid
<b>Impedance</b>	290 $\Omega$
<b>Sensitivity</b> (at 1 kHz, open circuit voltage)	-51.5 dB/Pa (2.66 mV/Pa)
<b>Polarity</b>	Positive pressure on diaphragm produces positive voltage on pin 2 with respect to pin 3
<b>Weight</b>	278 g
<b>Connector</b>	Three-pin professional audio (XLR), male



Beta 58A

## Accessories and Replacement Parts

<b>A25D</b> Adjustable Stand Adapter*	<b>95A2314</b> Storage Bag*	<b>95A2050</b> 5/8" to 3/8" Thread Adapter*	<b>A58WS</b> Windscreen (in different colours)
---------------------------------------	-----------------------------	---	--

\* included in delivery

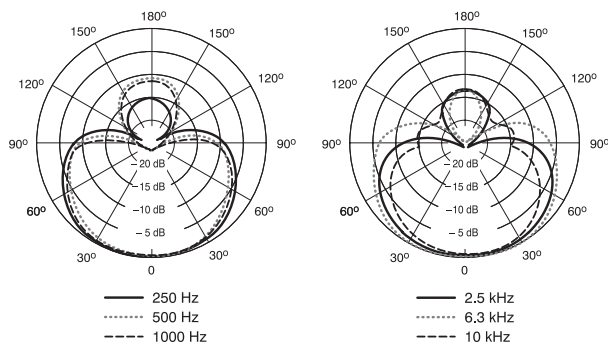

Polar Pattern

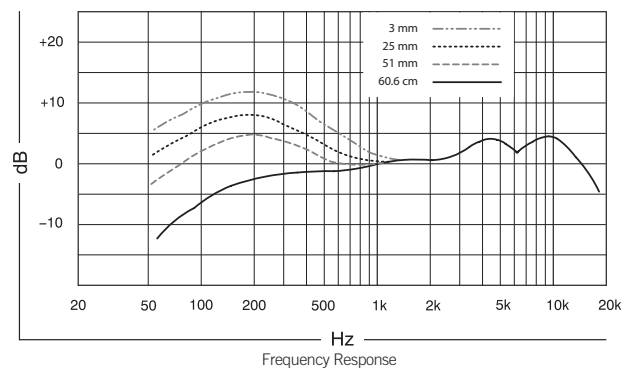

**SHURE**<sup>®</sup>  
LEGENDARY  
PERFORMANCE™

# Beta 87A Condenser Vocal Microphone (Supercardioid)

## Overview

The Beta 87A vocal condenser microphone offers a smooth, tailored response for a warm, present and accurate sound reproduction. The supercardioid polar pattern provides maximum sound isolation and minimum off-axis tone colouration.

## Features

- Highly consistent supercardioid polar pattern provides superior gain-before-feedback
- Smooth frequency response with gradual presence rise
- Wide dynamic range and low distortion characteristics
- Very low susceptibility to RFI and electromagnetic hum
- Built-in pop filter reduces undesirable wind and breath sounds
- Advanced cartridge shock-mount system absorbs mechanical shocks and reduces handling noise

## Specifications

<b>Type</b>	Condenser (electret)
<b>Frequency Response</b>	50 Hz to 20 kHz
<b>Polar Pattern</b>	Supercardioid
<b>Impedance</b>	100 Ω
<b>Sensitivity</b> (at 1 kHz, open circuit voltage)	-52.5 dBV/Pa (2.4 mV/Pa)
<b>Maximum SPL</b> (1 kHz at 1% THD)	140.5 dB (1 kΩ load)
<b>Signal-to-Noise Ratio</b> (referenced at 94 dB SPL at 1 kHz)	70.5 dB
<b>Dynamic Range</b> (at 1 kHz)	117 dB
<b>Clipping Level</b> (20 Hz-20 kHz at 1% THD)	-6 dBV (1 kΩ load)
<b>Self Noise</b> (typical, equivalent SPL, A-weighted)	23.5 dB(A)
<b>Polarity</b>	Positive pressure on diaphragm produces positive voltage on pin 2 with respect to pin 3
<b>Weight</b>	207 g
<b>Connector</b>	Three-pin professional audio (XLR), male
<b>Power Requirements</b>	11 - 52 Vdc phantom, 1.2 mA



Beta 87A

## Accessories and Replacement Parts

<b>A25D</b> Adjustable Stand Adapter*	<b>95A2314</b> Storage Bag*	<b>95A2050</b> 5/8" to 3/8" Thread Adapter*	<b>A85WS</b> Windscreen
---------------------------------------	-----------------------------	---	-------------------------

\* included in delivery

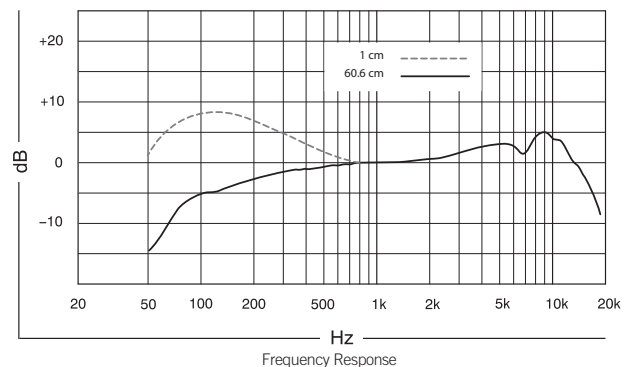
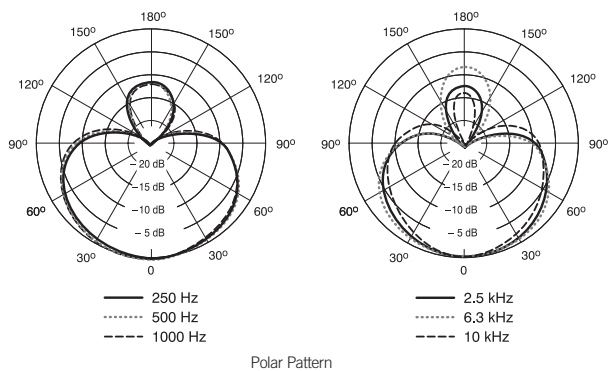

**SHURE**<sup>®</sup>  
LEGENDARY  
PERFORMANCE™

# Beta 87C Condenser Vocal Microphone (Cardioid)

## Overview

The cardioid polar pattern of the Beta 87C features an extremely smooth, tailored response for a warm, natural sound and an excellent rear rejection. It helps to compensate for the noise bleed, which is often associated with the use of personal monitors.

## Features

- Cardioid polar pattern for maximum isolation and minimal off-axis tone colouration
- Smooth, wide frequency response with slight presence rise
- Wide dynamic range
- Low-frequency roll-off compensates for proximity effect
- Built-in pop filter reduces undesirable wind and breath sounds
- Advanced cartridge shock-mount system absorbs mechanical shocks and reduces handling noise

## Specifications

<b>Type</b>	Condenser (electret)
<b>Frequency Response</b>	50 Hz to 20 kHz
<b>Polar Pattern</b>	Cardioid
<b>Impedance</b>	100 Ω
<b>Sensitivity</b> (at 1 kHz, open circuit voltage)	-51 dBV/Pa (2.8 mV/Pa)
<b>Maximum SPL</b> (1 kHz at 1% THD)	139 dB (1 kΩ load)
<b>Signal-to-Noise Ratio</b> (referenced at 94 dB SPL at 1 kHz)	72 dB
<b>Dynamic Range</b> (at 1 kHz)	117 dB
<b>Clipping Level</b> (20 Hz-20 kHz at 1% THD)	-6 dBV (1 kΩ load)
<b>Self Noise</b> (typical, equivalent SPL, A-weighted)	22 dB(A)
<b>Polarity</b>	Positive pressure on diaphragm produces positive voltage on pin 2 with respect to pin 3
<b>Weight</b>	207 g
<b>Connector</b>	Three-pin professional audio (XLR), male
<b>Power Requirements</b>	11 - 52 Vdc phantom, 1.2 mA



Beta 87C

## Accessories and Replacement Parts

**A25D** Adjustable Stand Adapter\*    **95A2314** Storage Bag\*    **95A2050** 5/8" to 3/8" Thread Adapter\*    **A85WS** Windscreen

\* included in delivery

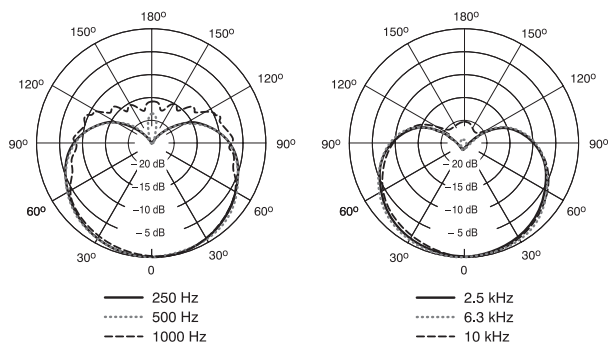

Polar Pattern

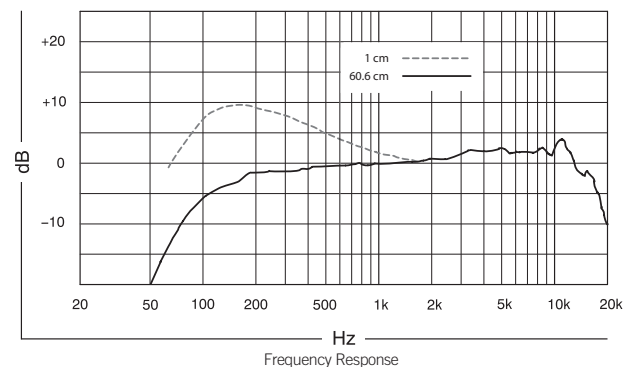

**SHURE**<sup>®</sup>  
 LEGENDARY  
 PERFORMANCE™

# Beta 53 Condenser Headworn Vocal Microphone (Omnidirectional)

## Overview

Delivers detailed, uncoloured vocal reproduction through an omnidirectional polar pattern in a lightweight and fully adjustable design. Ideal for spoken word and vocal applications such as theatre performance, speech, trade shows and seminars.

## Features

- Omnidirectional polar pattern for minimal handling noise and flexible microphone placement
- Extended, flat frequency response provides accurate speech and vocal reproduction
- Foam windscreens minimise breath noise and "popping"
- Available with an in-line preamp or with a TA4F connector for wireless applications
- Two interchangeable protective caps for response shaping

## Specifications

<b>Type</b>	Condenser (electret)
<b>Frequency Response</b>	20 Hz bis 20 kHz
<b>Polar Pattern</b>	Omnidirectional
<b>Impedance</b>	136 Ω
<b>Sensitivity</b> (at 1 kHz, open circuit voltage)	-50 dBV/Pa (3.16 mV/Pa)
<b>Maximum SPL</b> (1 kHz at 1% THD)	147 dB (1 kΩ load)
<b>Signal-to-Noise Ratio</b> (referenced at 94 dB SPL at 1 kHz)	55 dB
<b>Dynamic Range</b> (at 1 kHz)	108 dB
<b>Self Noise</b> (typical, equivalent SPL, A-weighted)	39 dB(A)
<b>Polarity</b>	Positive pressure on diaphragm produces positive voltage on pin 2 with respect to pin 3
<b>Weight</b>	135 g; 35 g microphone
<b>Connector</b>	3 Pin XLR (TA4F at microphone)
<b>Power Requirements</b>	11 - 52 Vdc phantom, 4.6 mA



Beta 53

## Accessories and Replacement Parts

<b>RPM304</b>	Foam Windscreen*	<b>RPM208</b>	Standard Protective Cap - gold mesh*	<b>RPM220</b>	Filtered Protective Cap - silver mesh*
<b>RPM510</b>	Swiveling Lapel Clip*	<b>RPM626</b>	In-Line Preamp*	<b>95B2234</b>	Carrying Case*

\* included in delivery

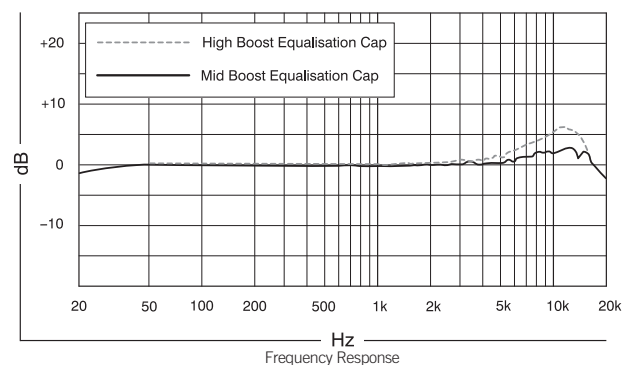
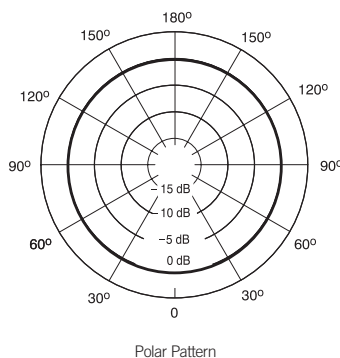

**SHURE**<sup>®</sup>  
LEGENDARY  
PERFORMANCE™

# Beta 54 Condenser Headworn Vocal Microphone (Supercardioid)

## Overview

Features a smooth, tailored response for a warm, natural sound in a lightweight and fully adjustable design. The supercardioid polar pattern provides maximum sound isolation and is ideal for lead and backing vocals on stage and for live recording applications.

## Features

- Supercardioid polar pattern provides maximum gain-before-feedback and ambient rejection
- Extended frequency response tailored for vocal performances
- Able to handle high sound pressure levels (SPL)
- Snap-fit foam windscreens stay in place during intensive movement
- Available with an in-line preamp or with a TA4F connector for wireless applications

## Specifications

<b>Type</b>	Condenser (electret)
<b>Frequency Response</b>	20 Hz to 20 kHz
<b>Polar Pattern</b>	Supercardioid
<b>Impedance</b>	136 Ω
<b>Sensitivity</b> (at 1 kHz, open circuit voltage)	-52 dBV/Pa (2.5 mV/Pa)
<b>Maximum SPL</b> (1 kHz at 1% THD)	149 dB (1 kΩ load)
<b>Signal-to-Noise Ratio</b> (referenced at 94 dB SPL at 1 kHz)	55 dB
<b>Dynamic Range</b> (at 1 kHz)	110 dB
<b>Self Noise</b> (typical, equivalent SPL, A-weighted)	39 dB(A)
<b>Polarity</b>	Positive pressure on diaphragm produces positive voltage on pin 2 with respect to pin 3
<b>Weight</b>	135 g; 35 g microphone
<b>Connector</b>	3 Pin XLR (TA4F at microphone)
<b>Power Requirements</b>	11 - 52 Vdc phantom, 4.6 mA



Beta 54

## Accessories and Replacement Parts

<b>RPM316</b> Windscreen*	<b>RPM208</b> Standard Protective Cap - gold mesh*	<b>RPM510</b> Swiveling Lapel Clip*
<b>RPM626</b> In-Line Preamp*	<b>95B2234</b> Carrying Case*	

\* included in delivery

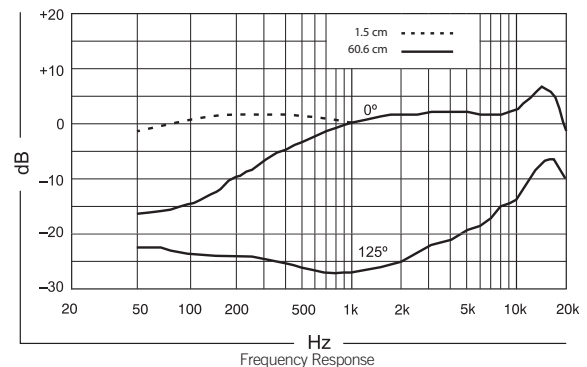
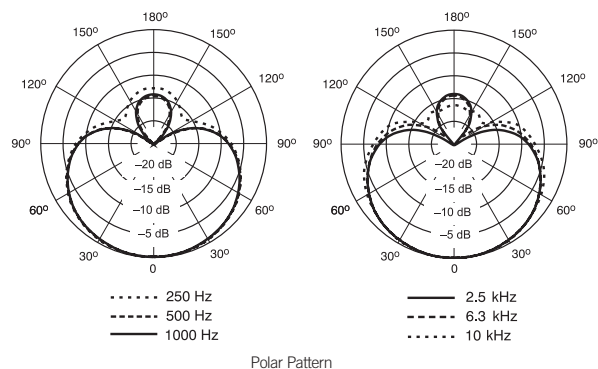

**SHURE**<sup>®</sup>  
LEGENDARY  
PERFORMANCE™

# Beta 57A Dynamic Instrument Microphone (Supercardioid)

## Overview

The Beta 57A provides a warm, tailored and present sound for amplified or acoustic instruments. A tight supercardioid polar pattern provides high gain-before-feedback and maximum sound isolation, with minimum off-axis tone colouration.

## Features

- Uniform supercardioid polar pattern for high gain-before-feedback and superior rejection of off-axis sound
- Neodymium magnet for high signal-to-noise ratio output
- Advanced pneumatic shock-mount system that minimises transmission of mechanical noise and vibration
- Hardened steel mesh grille that facilitates use of proximity effect and resists wear and abuse
- Minimally affected by varying load impedance

## Specifications

<b>Type</b>	Dynamic
<b>Frequency Response</b>	50 Hz to 16 kHz
<b>Polar Pattern</b>	Supercardioid
<b>Impedance</b>	290 $\Omega$
<b>Sensitivity</b> (at 1 kHz, open circuit voltage)	-51 dB/Pa (2.8 mV/PA)
<b>Polarity</b>	Positive pressure on diaphragm produces positive voltage on pin 2 with respect to pin 3
<b>Weight</b>	275 g
<b>Connector</b>	Three-pin professional audio (XLR), male



Beta 57A

## Accessories and Replacement Parts

<b>A25D</b> Adjustable Stand Adapter*	<b>95A2314</b> Storage Bag*	<b>95A2050</b> 5/8" to 3/8" Thread Adapter*	<b>A57AWS</b> Windscreen
---------------------------------------	-----------------------------	---	--------------------------

\* included in delivery

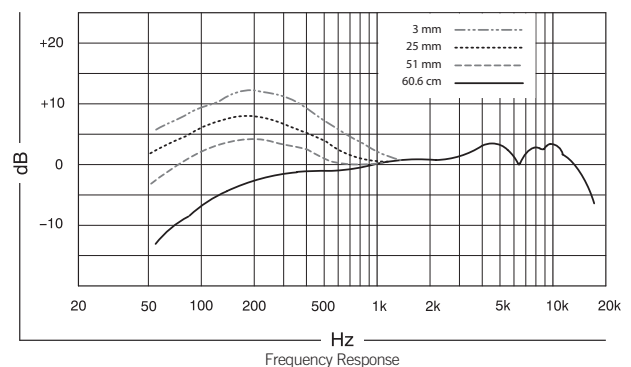
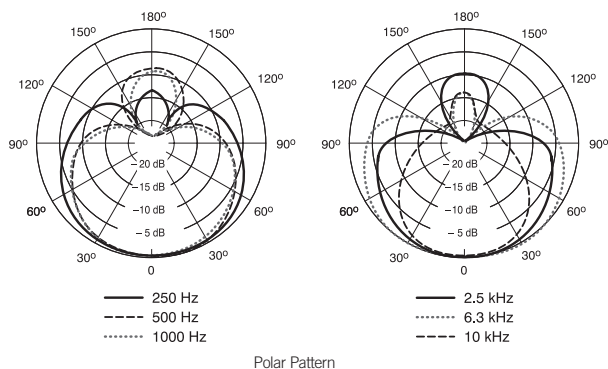

**SHURE**<sup>®</sup>  
LEGENDARY  
PERFORMANCE™

# Beta 27 Large-Diaphragm Side-Address Condenser Instrument Microphone (Supercardioid)

## Overview

The Beta 27 is a large-diaphragm condenser microphone especially designed for on stage use. Low self-noise and a supercardioid polar pattern that delivers high gain-before-feedback makes the Beta 27 ideal for critical live and studio applications. It has a flat, neutral frequency response for natural sound reproduction.

## Features

- Supercardioid polar pattern specifically targets the sound source consistently with greatly minimised bleed from off-axis sound sources
- Tailored for superior transient response from a low-mass, 1" externally-biased, ultra-thin 24 Karat gold-layered Mylar® diaphragm
- Flat, neutral frequency response for natural reproduction on stage or in the studio
- 3-position switchable low-frequency filter helps reduce unwanted background noise or counteract proximity effect for consistent, extended low-end
- -15 dB switchable attenuator handles extremely high SPLs with ease
- Premium electronic components and gold-plated internal and external connectors
- Internal pop-filter with three separate mesh layers reduces wind and breath noise

## Specifications

<b>Type</b>	Condenser (externally biased)
<b>Frequency Response</b>	20 Hz to 20 kHz
<b>Polar Pattern</b>	Supercardioid
<b>Impedance</b>	160 Ω
<b>Sensitivity</b> (at 1 kHz, open circuit voltage)	-37 dBV/Pa (14.1 mV/Pa) 1 Pascal=94 dB SPL
<b>Maximum SPL</b> (1 kHz at 1% THD)	134 dB (1 kΩ load) Pad off 140 dB (2.5 kΩ load) Pad off
<b>Signal-to-Noise Ratio</b> (referenced at 94 dB SPL at 1 kHz)	85.5 dB
<b>Dynamic Range</b> (at 1 kHz)	125.5 dB (1 kΩ load) 131.5 dB (2.5 kΩ load)
<b>Clipping Level</b> (20 Hz-20 kHz at 1% THD)	2.0 dBV (1 kΩ load) 8.5 dBV (2.5 kΩ load)
<b>Self Noise</b> (typical, equivalent SPL, A-weighted)	8.5 dB(A)
<b>Polarity</b>	Positive pressure on diaphragm produces positive voltage on pin 2 with respect to pin 3
<b>Weight</b>	428 g
<b>Switch</b>	Attenuator: -15 dB Low Frequency Response: -6 dB/octave below 115 Hz; -18 dB/octave below 80 Hz
<b>Connector</b>	Three-pin professional audio (XLR), male
<b>Power Requirements</b>	48 Vdc phantom, 5.6 mA



Beta 27

## Accessories and Replacement Parts

<b>A32M</b>	ShureLock Black Swivel Adapter*	<b>A27ZB</b>	Zippered Pouch*	<b>95A2050</b>	5/8" to 3/8" Thread Adapter*
<b>A32WS</b>	Windscreen	<b>A27SM</b>	ShureLock Rubber Isolated Shock-Mount	<b>PS-6</b>	Popper Stopper

\* included in delivery

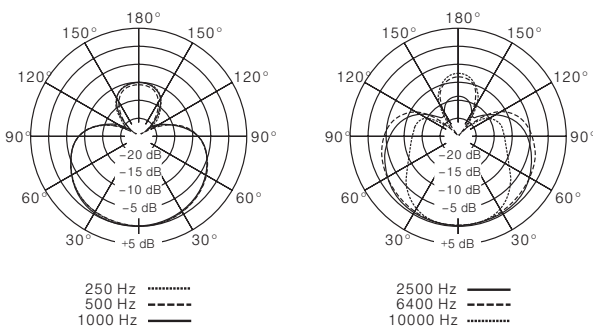

Polar Pattern

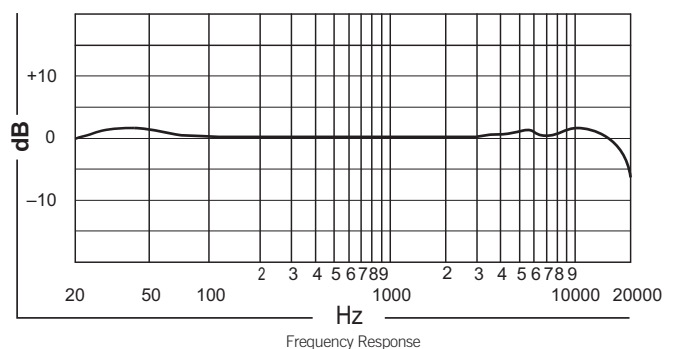

Frequency Response

**SHURE**  
LEGENDARY  
PERFORMANCE™

# Beta 181 Condenser Side-Address Microphone (Interchangeable Capsules)

## Overview

Featuring an ultra compact, small diaphragm side-address condenser microphone, the Beta 181 offers interchangeable capsules for different polar patterns. This enables discreet placement and versatility in tight conditions for various applications.

## Features

- Interchangeable polar pattern capsules attached to a compact preamplifier with integrated XLR connections
- Precision-engineered, compact side-address design features innovative locking ring to provide secure connection between capsule and preamplifier
- Capsules available separately for custom flexibility

## Available Models

**Beta 181/C** (cardioid) for drum overhead, piano, acoustic instrument applications    **Beta 181/S** (supercardioid) for snare drum, acoustic instrument, close-miking applications

**Beta 181/O** (omnidirectional) for ambient/room, instrument ensemble applications    **Beta 181/BI** (bidirectional) for mono drum overhead, dual instrument sound source applications



Beta 181

## Specifications

<b>Type</b>	Condenser (electret)				
<b>Frequency Response</b>	20 Hz to 20 kHz				
<b>Polar Pattern</b>	Interchangeable Capsules (Cardioid, Supercardioid, Omnidirectional, Bidirectional)				
<b>Impedance</b>	110 Ω				
<b>Sensitivity</b> (at 1 kHz, open circuit voltage)	<b>Beta 181/C</b> -46.5 dBV/Pa	<b>Beta 181/S</b> -49.5 dBV/Pa	<b>Beta 181/O</b> -52.0 dBV/Pa	<b>Beta 181/BI</b> -51.0 dBV/Pa	
<b>Maximum SPL</b> (1 kHz at 1% THD)	149.0 dB 151.5 dB	152.0 dB 154.5 dB	154.0 dB 157.0 dB	153.5 dB 156.0 dB	(1 kΩ load) (2.5 kΩ load)
<b>Signal-to-Noise Ratio</b> (referenced at 94 dB SPL at 1 kHz)	73.5 dB	71.5 dB	70.5 dB	71.0 dB	
<b>Dynamic Range</b> (at 1 kHz)	128.5 dB 131.0 dB	129.5 dB 132.0 dB	130.5 dB 133.5 dB	130.5 dB 133.0 dB	(1 kΩ load) (2.5 kΩ load)
<b>Clipping Level</b> (20 Hz-20 kHz at 1% THD)	7.5 dBV				
<b>Self Noise</b> (typical, equivalent SPL, A-weighted)	20.5 dB(A)	22.5 dB(A)	23.5 dB(A)	23.0 dB(A)	
<b>Polarity</b>	Positive pressure on diaphragm produces positive voltage on pin 2 with respect to pin 3				
<b>Weight</b>	12 g				
<b>Connector</b>	Three-pin professional audio (XLR), male				
<b>Power Requirements</b>	11 - 52 Vdc phantom, 1.2 mA				

## Accessories and Replacement Parts

<b>A57F</b>	Mic Clip*	<b>A181WS</b>	Windscreen*	<b>A181C</b>	Zippered Carrying Case*	<b>95A2050</b>	5/8" to 3/8" Thread Adapter*
<b>RPM181/O</b>	Omnidirectional Capsule	<b>RPM181/C</b>	Cardioid Capsule	<b>RPM181/S</b>	Supercardioid Capsule	<b>RPM181/BI</b>	Bidirectional Capsule

\* included in delivery

### Beta 181/C (Cardioid)

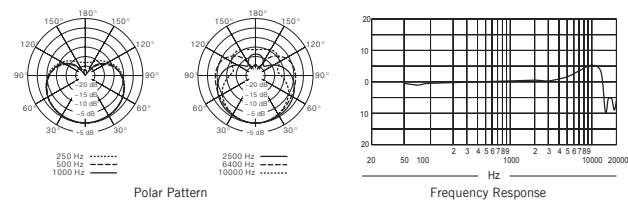

### Beta 181/O (Omnidirectional)

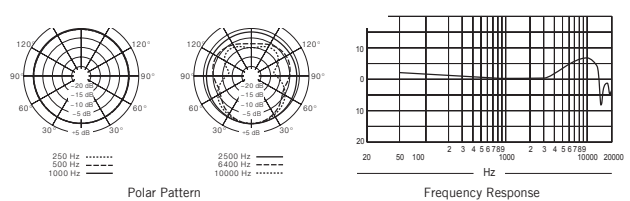

### Beta 181/S (Supercardioid)

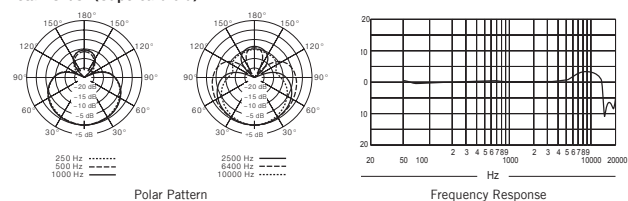

### Beta 181/BI (Bidirectional)

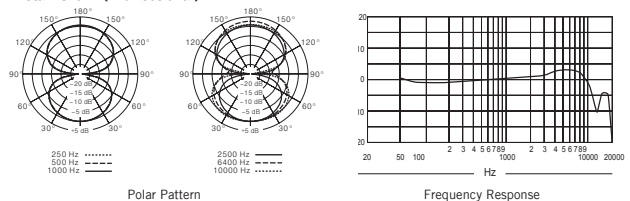

# Beta 98H/C Condenser Instrument Microphone (Cardioid)

## Overview

Built for brass, woodwind and percussion instruments, the Beta 98H/C uses a miniature cardioid condenser microphone with a tailored frequency response for open, natural sound. It has a flexible gooseneck mount that clamps directly to the bell or rim for precise positioning.

## Features

- Uniform cardioid pattern provides for high gain-before-feedback and high rejection of ambient sound
- Tailored frequency response for open, natural sound reproduction
- Designed for use in high SPL environments
- Compact, lightweight construction provides a low degree of visibility
- Adjustable gooseneck and ratcheting swivel joint allow for optimal microphone positioning
- Interchangeable microphone cartridges with different pick-up pattern options

## Specifications

<b>Type</b>	Condenser (electret)
<b>Frequency Response</b>	20 Hz to 20 kHz
<b>Polar Pattern</b>	Cardioid
<b>Impedance</b>	150 Ω
<b>Sensitivity</b> (at 1 kHz, open circuit voltage)	-56 dBV/Pa (1.6 mV/Pa)
<b>Maximum SPL</b> (1 kHz at 1% THD)	155 dB (1 kΩ load) 163 dB (2.5 kΩ load)
<b>Signal-to-Noise Ratio</b> (referenced at 94 dB SPL at 1 kHz)	63 dB
<b>Dynamic Range</b> (at 1 kHz)	124 dB (1 kΩ load) 132 dB (2.5 kΩ load)
<b>Clipping Level</b> (20 Hz-20 kHz at 1% THD)	3 dBV (1 kΩ load) 11 dBV (2.5 kΩ load)
<b>Self Noise</b> (typical, equivalent SPL, A-weighted)	31 dB(A)
<b>Polarity</b>	Positive pressure on diaphragm produces positive voltage on pin 2 with respect to pin 3
<b>Weight</b>	156 g
<b>Connector</b>	Three-pin professional audio (XLR), male
<b>Power Requirements</b>	11 - 52 Vdc phantom



Beta 98H/C

## Accessories and Replacement Parts

<b>95A2314</b> Storage Bag*	<b>95A2064</b> Windscreen*	<b>RPM108</b> Cardioid Capsule*	<b>RPM110</b> Supercardioid Capsule
-----------------------------	----------------------------	---------------------------------	-------------------------------------

\* included in delivery

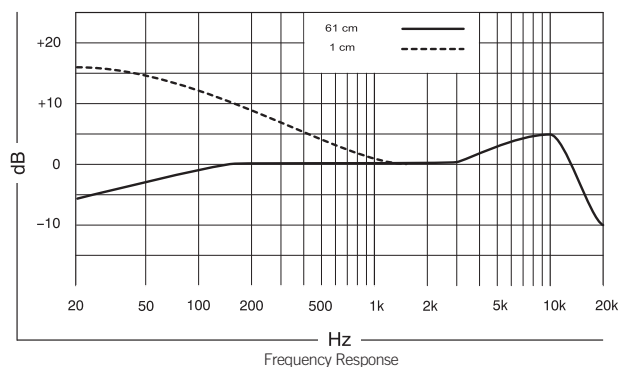
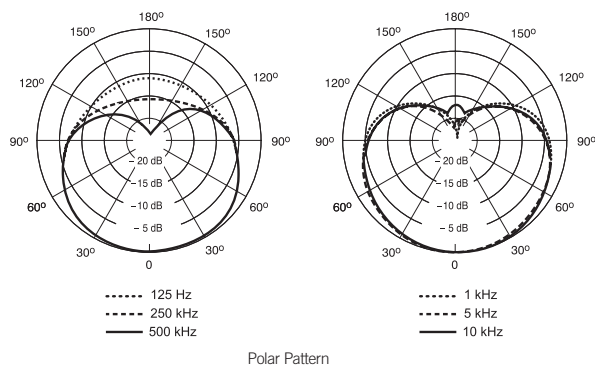

**SHURE**<sup>®</sup>  
LEGENDARY  
PERFORMANCE™

# Beta 98S and Beta 98D/S Condenser Instrument Microphone (Supercardioid)

## Overview

Precision-engineered for high SPL instrument applications, the Beta 98S and Beta 98D/S provide a clear and detailed sound reproduction. The supercardioid polar pattern offers excellent rejection of unwanted sound and high gain-before-feedback. Swivel adapter for Beta 98S included. A98D drum mount with flexible gooseneck for accurate and secure placement for Beta 98D/S included.

## Features

- Uniform supercardioid polar pattern for high gain-before-feedback and superior rejection of off-axis sound
- Tailored frequency response for studio quality performance
- Wide dynamic range for use in high SPL environments
- Detachable cable for easy storage
- Interchangeable microphone cartridges with different polar pattern options

## Available Models

**Beta 98S** With swivel adapter (RK282)

**Beta 98D/S** With drum mount and gooseneck (A98D)



Beta 98S

## Specifications

<b>Type</b>	Condenser (electret)
<b>Frequency Response</b>	20 Hz to 20 kHz
<b>Polar Pattern</b>	Supercardioid
<b>Impedance</b>	150 Ω
<b>Sensitivity</b> (at 1 kHz, open circuit voltage)	-59 dBV/Pa (1.1 mV/Pa)
<b>Maximum SPL</b> (1 kHz at 1% THD)	156 dB (1 kΩ load) 160 dB (2.5 kΩ load)
<b>Signal-to-Noise Ratio</b> (referenced at 94 dB SPL at 1 kHz)	59 dB
<b>Dynamic Range</b> (at 1 kHz)	121 dB (1 kΩ load) 125 dB (2.5 kΩ load)
<b>Clipping Level</b> (20 Hz-20 kHz at 1% THD)	2 dBV (1 kΩ load) 6 dBV (2.5 kΩ load)
<b>Self Noise</b> (typical, equivalent SPL, A-weighted)	35 dB(A)
<b>Polarity</b>	Positive pressure on diaphragm produces positive voltage on pin 2 with respect to pin 3
<b>Weight</b>	12 g (only microphone capsule)
<b>Connector</b>	3 Pin XLR (TA3M at microphone)
<b>Power Requirements</b>	48+/- 4 Vdc phantom, 1.2 mA



Beta 98D/S

## Accessories and Replacement Parts

<b>RPM626</b> Preamplifier*	<b>95A2314</b> Storage Bag*	<b>95A2064</b> Windscreen*	<b>RPM110</b> Supercardioid Capsule*	<b>RPM108</b> Cardioid Capsule
With <b>Beta 98S</b> included:	<b>95A2398</b> 7.6 m Lightweight Cable TA3F to TA4F	<b>RK282</b> Shock-Mount Swivel Adapter	<b>95A2050</b> 5/8" to 3/8" Thread Adapter	
With <b>Beta 98D/S</b> included:	<b>C98D</b> 4.6 m Cable, TA3F to TA4F	<b>A98D</b> Gooseneck Mount		

\* included in delivery

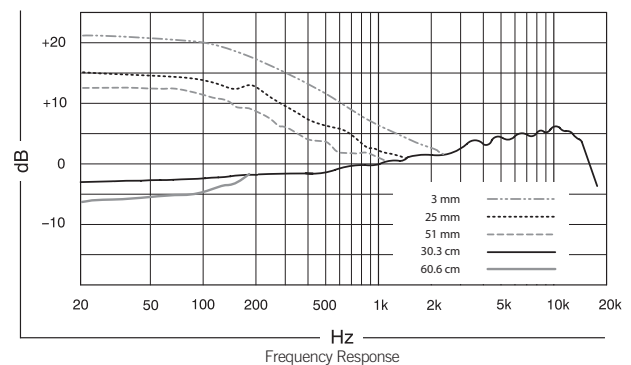
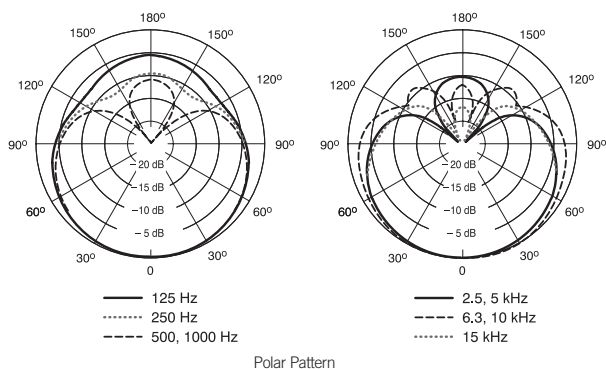

**SHURE**<sup>®</sup>  
 LEGENDARY  
 PERFORMANCE™

# Beta 98A/C and Beta 98AD/C Condenser Instrument Microphone (Cardioid)

## Overview

Precision-engineered with a high output miniature cardioid condenser microphone, the Beta 98A/C and Beta 98AD/C provide warm, natural sound reproduction, with smooth high-end response. The compact design allows for discreet placement on a variety of acoustic or amplified instruments. Swivel adapter for Beta 98A/C included. A98D drum mount with flexible gooseneck for accurate and secure placement for Beta 98AD/C included.

## Features

- Uniform cardioid polar pattern provides maximum gain-before-feedback
- Frequency response tailored for drums and percussion applications
- Precision-engineered, for unobtrusive microphone design
- Wide dynamic range for use in high SPL environments

## Available Models

**Beta 98A/C** With RK282 shock-mount swivel adapter for attachment to any standard microphone stand

**Beta 98AD/C** With A98D drum mount featuring a flexible gooseneck for precise placement and secure attachment



Beta 98A/C



Beta 98AD/C

## Specifications

<b>Type</b>	Condenser (electret)
<b>Frequency Response</b>	20 Hz to 20 kHz
<b>Polar Pattern</b>	Cardioid
<b>Impedance</b>	179 Ω
<b>Sensitivity</b> (at 1 kHz, open circuit voltage)	-48 dBV/Pa (4 mV/Pa)
<b>Maximum SPL</b> (1 kHz at 1% THD)	144.0 dB (1 kΩ load) 150.5 dB (2.5 kΩ load)
<b>Signal-to-Noise Ratio</b> (referenced at 94 dB SPL at 1 kHz)	64 dB
<b>Dynamic Range</b> (at 1 kHz)	114.0 dB (1 kΩ load) 120.5 dB (2.5 kΩ load)
<b>Clipping Level</b> (20 Hz-20 kHz at 1% THD)	1.0 dBV (1 kΩ load) 8.0 dBV (2.5 kΩ load)
<b>Self Noise</b> (typical, equivalent SPL, A-weighted)	30 dB(A)
<b>Polarity</b>	Positive pressure on diaphragm produces positive voltage on pin 2 with respect to pin 3
<b>Weight</b>	12 g (only microphone capsule)
<b>Connector</b>	3 Pin XLR (TA3M at microphone)
<b>Power Requirements</b>	11 - 52 Vdc phantom, 3.6 mA

## Accessories and Replacement Parts

<b>RPM626</b> Preamplifier*	<b>95A2064</b> Windscreen*	<b>95A2314</b> Carrying/Storage Bag*	<b>RPM98A/C</b> Replacement Cartridge
With <b>Beta 98A/C</b> included:	<b>95A2050</b> 5/8" to 3/8" Thread Adapter	<b>95A2398</b> 7.6 m Lightweight Cable	<b>RK282</b> Shock-Mount Swivel Adapter
With <b>Beta 98AD/C</b> included:	<b>A98D</b> Gooseneck Mount	<b>C98D</b> 4.6 m Lightweight Cable, TA3F to TA4F	

\* included in delivery

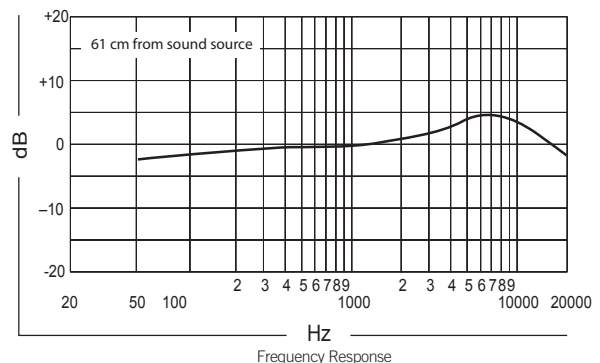
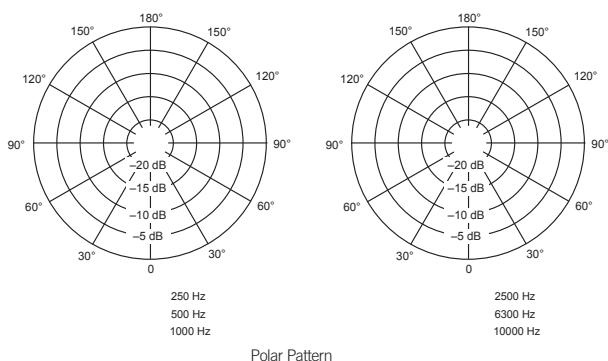

**SHURE**<sup>®</sup>  
LEGENDARY  
PERFORMANCE™

# Beta 98AMP/C Condenser Drum Microphone (Cardioid)

## Overview

The cardioid condenser microphone Beta 98AMP/C with integrated preamplifier, provides a smooth, natural, tailored response. It has an extremely high maximum SPL and wide dynamic range, ideal for drums and percussion. It offers a flexible gooseneck and the A75M universal microphone mount for accurate and secure placement in any configuration.

## Features

- Uniform cardioid polar pattern provides maximum gain-before-feedback
- Rejection of off-axis sound for smooth high-end response and control
- Frequency response tailored for drums and percussion applications with a wide dynamic range for use in high SPL environments
- Precision-engineered design features integrated preamplifier and XLR connector
- Flexible gooseneck for precise placement and easy adjustment
- Ships with A75M universal microphone mount for secure placement

## Specifications

<b>Type</b>	Condenser (electret)
<b>Frequency Response</b>	20 Hz to 20 kHz
<b>Polar Pattern</b>	Cardioid
<b>Impedance</b>	150 Ω
<b>Sensitivity</b> (at 1 kHz, open circuit voltage)	-50.5 dBV/Pa (3 mV/Pa)
<b>Maximum SPL</b> (1 kHz at 1% THD)	153 dB (1 kΩ load) 157.5 dB (2.5 kΩ load)
<b>Signal-to-Noise Ratio</b> (referenced at 94 dB SPL at 1 kHz)	63.0 dB
<b>Dynamic Range</b> (at 1 kHz)	122.0 dB (1 kΩ load) 126.5 dB (2.5 kΩ load)
<b>Clipping Level</b> (20 Hz-20 kHz at 1% THD)	7.5 dBV (1 kΩ load) 12.5 dBV (2.5 kΩ load)
<b>Self Noise</b> (typical, equivalent SPL, A-weighted)	31 dB(A)
<b>Polarity</b>	Positive pressure on diaphragm produces positive voltage on pin 2 with respect to pin 3
<b>Weight</b>	130 g
<b>Connector</b>	Three-pin professional audio (XLR), male
<b>Power Requirements</b>	11 - 52 Vdc phantom, 3.6 mA



Beta 98AMP/C

## Accessories and Replacement Parts

<b>A75M</b>	Universal Microphone Mount*	<b>95A2314</b>	Storage Bag*	<b>A75-57F</b>	Mic Clip*
<b>95A2050</b>	5/8" to 3/8" Thread Adapter*	<b>95A2064</b>	Snap-fit Windscreen		

\* included in delivery

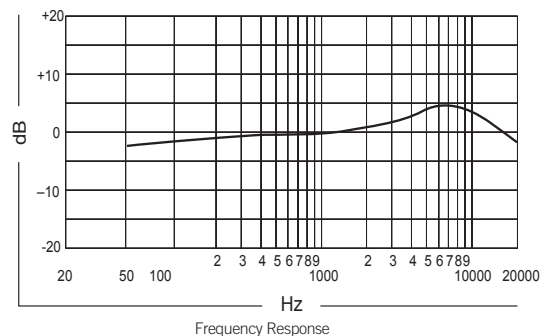
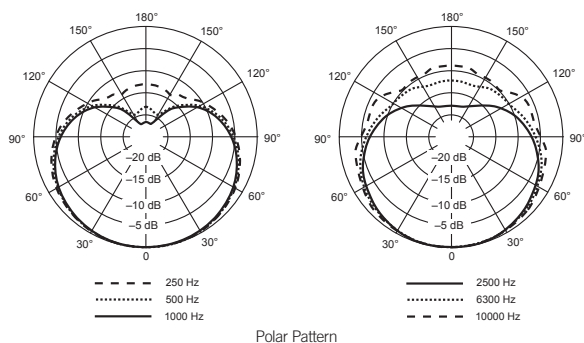

**SHURE**<sup>®</sup>  
LEGENDARY  
PERFORMANCE™

# Beta 91A Condenser Instrument Microphone (Half-Cardioid)

## Overview

The Beta 91A is optimised for kick drums and other low frequency applications. It uses a half-cardioid condenser boundary microphone with an integrated XLR preamplifier that is tailored for a strong low-end response. It has a two-position contour switch for optimised sound signature depending on application.

## Features

- Uniform half-cardioid polar pattern for maximum gain-before-feedback
- Frequency response tailored for kick drums and low frequency application
- Precision-engineered low-profile design features integrated preamplifier
- Two-position switch to maximise attack depending on application
- Flat response setting for natural sound
- „Low-mid scoop“ setting for a strong low frequency „punch“

## Specifications

<b>Type</b>	Condenser (electret)
<b>Frequency Response</b>	20 Hz to 20 kHz
<b>Polar Pattern</b>	Half-Cardioid
<b>Impedance</b>	146 Ω
<b>Sensitivity</b> (at 1 kHz, open circuit voltage)	-48.5 dBV/Pa (3.8 mV/Pa)
<b>Maximum SPL</b> (1 kHz at 1% THD)	151 dB (1 kΩ load) 155 dB (2.5 kΩ load)
<b>Signal-to-Noise Ratio</b> (referenced at 94 dB SPL at 1 kHz)	64.0 dB
<b>Dynamic Range</b> (at 1 kHz)	121 dB (1 kΩ load) 125 dB (2.5 kΩ load)
<b>Clipping Level</b> (20 Hz-20 kHz at 1% THD)	7.5 dBV (1 kΩ load) 12.5 dBV (2.5 kΩ load)
<b>Self Noise</b> (typical, equivalent SPL, A-weighted)	30.0 dB(A)
<b>Polarity</b>	Positive pressure on diaphragm produces positive voltage on pin 2 with respect to pin 3
<b>Weight</b>	470 g
<b>Switch</b>	-7dB attenuation centred at 400 Hz
<b>Connector</b>	Three-pin professional audio (XLR), male
<b>Power Requirements</b>	11 - 52 Vdc phantom, 5.6 mA



Beta 91A

## Accessories and Replacement Parts

<b>95A2314</b>	Zippered Pouch*	<b>RPM98A/C</b>	Replacement Cartridge
----------------	-----------------	-----------------	-----------------------

\* included in delivery

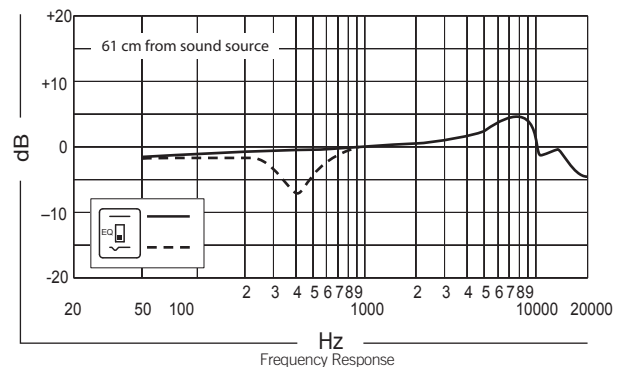
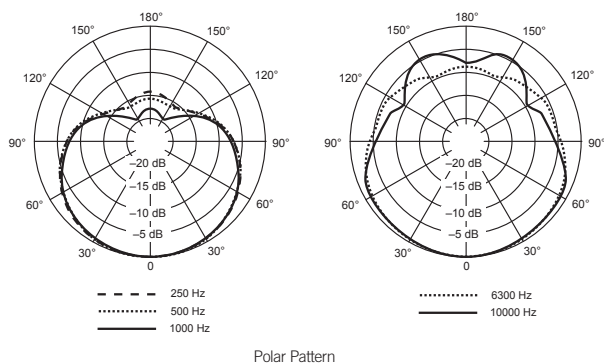

**SHURE**<sup>®</sup>  
LEGENDARY  
PERFORMANCE™

# Beta 52A Dynamic Kick Drum Microphone (Supercardioid)

## Overview

Featuring an integrated locking stand adapter, the extremely rugged Beta 52A with its supercardioid pattern provides superb attack and “punch”. Ideal for kick drums and other low-frequency applications.

## Features

- Supercardioid pattern for high gain-before-feedback and superior rejection of unwanted noise
- Low sensitivity to varying load impedance
- Studio quality performance, even at extremely high sound pressure levels
- Neodymium magnet for high signal-to-noise ratio output
- Built-in dynamic locking stand adapter with integral XLR connector simplifies setup
- Advanced pneumatic shock-mount system that minimises transmission of mechanical noise and vibration

## Specifications

<b>Type</b>	Dynamic
<b>Frequency Response</b>	20 Hz to 10 kHz
<b>Polar Pattern</b>	Supercardioid
<b>Impedance</b>	45 Ω
<b>Sensitivity</b> (at 1 kHz, open circuit voltage)	-64 dBV/Pa (0.6 mV/Pa)
<b>Maximum SPL</b> (1 kHz at 1% THD)	174 dB
<b>Polarity</b>	Positive pressure on diaphragm produces positive voltage on pin 2 with respect to pin 3
<b>Weight</b>	605 g
<b>Connector</b>	Three-pin professional audio (XLR), male



Beta 52A

## Accessories and Replacement Parts

<b>95A2314</b>	Storage Bag*	<b>95A2050</b>	5/8" to 3/8" Thread Adapter*
----------------	--------------	----------------	------------------------------

\* included in delivery

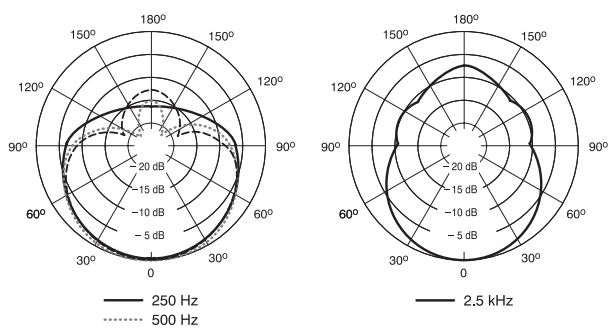

Polar Pattern

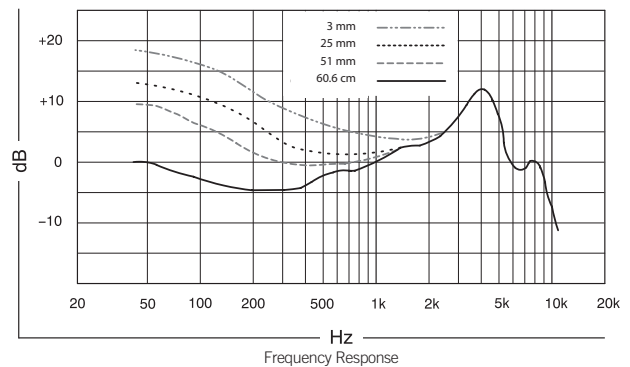

**SHURE**<sup>®</sup>  
LEGENDARY  
PERFORMANCE™

# Beta 56A Dynamic Drum Microphone (Supercardioid)

## Overview

The supercardioid polar pattern of the Beta 56A ensures maximum sound isolation and offers warm, present sound and "punch". Specifically tailored for close miking of snares and toms, it features an integrated locking stand adapter.

## Features

- Uniform supercardioid pattern for high gain-before-feedback and superior rejection of off-axis sound
- Minimally affected by varying load impedance
- Compact design reduces stage clutter
- Neodymium magnet for high signal-to-noise ratio output
- Built-in stand adapter with dynamic locking system and XLR connector simplifies setup and provides greater flexibility
- Advanced pneumatic shock-mount system that minimises transmission of mechanical noise and vibration

## Specifications

<b>Type</b>	Dynamic
<b>Frequency Response</b>	50 Hz to 16 kHz
<b>Polar Pattern</b>	Supercardioid
<b>Impedance</b>	290 Ω
<b>Sensitivity</b> (at 1 kHz, open circuit voltage)	-51 dBV/Pa (2.8 mV/Pa)
<b>Polarity</b>	Positive pressure on diaphragm produces positive voltage on pin 2 with respect to pin 3
<b>Weight</b>	468 g
<b>Connector</b>	Three-pin professional audio (XLR), male



Beta 56A

## Accessories and Replacement Parts

<b>95A2314</b>	Storage Bag*	<b>95A2050</b>	5/8" to 3/8" Thread Adapter*	<b>A1WS</b>	Windscreen
----------------	--------------	----------------	------------------------------	-------------	------------

\* included in delivery

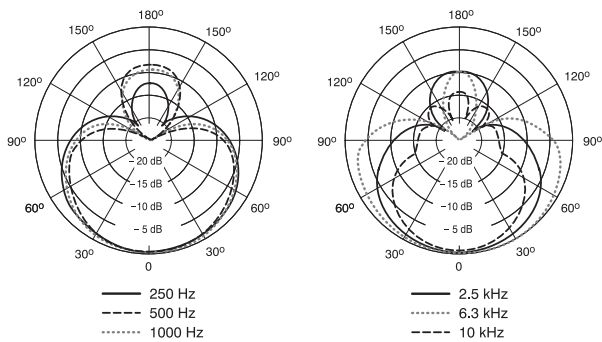

Polar Pattern

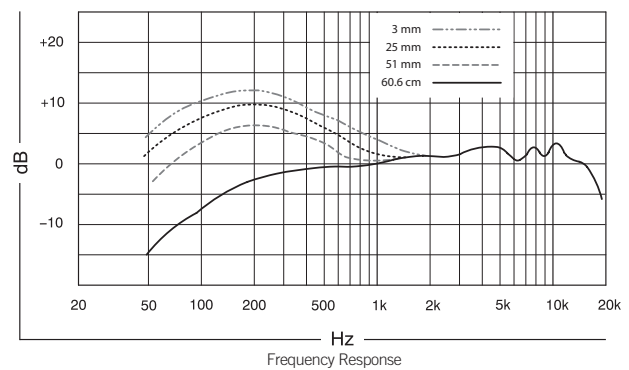

Frequency Response

**SHURE**  
LEGENDARY  
PERFORMANCE™



Whilst every effort has been made to ensure that the information in this document is correct, we accept no liability in respect of errors or omissions. All specifications within this document are subject to change without notice.

© 2010 Shure Incorporated