

# FOX3 T 201

Fiber Optic HDMI Transmitter



# Safety Instructions

## Safety Instructions • English

**⚠ WARNING:** This symbol, , when used on the product, is intended to alert the user of the presence of uninsulated dangerous voltage within the product's enclosure that may present a risk of electric shock.

**⚠ ATTENTION:** This symbol, , when used on the product, is intended to alert the user of important operating and maintenance (servicing) instructions in the literature provided with the equipment.

For information on safety guidelines, regulatory compliances, EMI/EMF compatibility, accessibility, and related topics, see the Extron Safety and Regulatory Compliance Guide, part number 68-290-01, on the Extron website, [www.extron.com](http://www.extron.com).

## تعليمات السلامة • العربية

**⚠ تحذير:** هذا الرمز، , عند استخدامه على المنتج، مخصص لتنبيه المستخدم فيما يتعلق بوجود جهد كهربائي غير معزول على الغلاف الخارجي للمنتج وهو ما قد ينطوي على مخاطر حدوث صدمة كهربائية.

**⚠ انتبه:** هذا الرمز، , عند استخدامه على المنتج، مخصص لتنبيه المستخدم بتعليمات التشغيل والصيانة الهامة (الخدمة) في المواد التي يتم توفيرها مع المعدات.

للحصول على المزيد من المعلومات حول إرشادات السلامة، والتوافق التنظيمية، والتوافق الكهرومغناطيسي/المجال الكهرومغناطيسي، وإمكانية الوصول، والموضوعات ذات الصلة، يُرجى مراجعة دليل السلامة والتوافق التنظيمي [www.extron.com](http://www.extron.com) الخاص بإكسترون، الجزء رقم 68-290-01، على موقع إكسترون.

## Sicherheitsanweisungen • Deutsch

**⚠ WARUNG:** Dieses Symbol , auf dem Produkt soll den Benutzer darauf aufmerksam machen, dass im Inneren des Gehäuses dieses Produktes gefährliche Spannungen herrschen, die nicht isoliert sind und die einen elektrischen Schlag verursachen können.

**⚠ VORSICHT:** Dieses Symbol , auf dem Produkt soll dem Benutzer in der im Lieferumfang enthaltenen Dokumentation besonders wichtige Hinweise zur Bedienung und Wartung (Instandhaltung) geben.

Weitere Informationen über die Sicherheitsrichtlinien, Produkthandhabung, EMI/EMF-Kompatibilität, Zugänglichkeit und verwandte Themen finden Sie in den Extron-Richtlinien für Sicherheit und Handhabung (Artikelnummer 68-290-01) auf der Extron-Website, [www.extron.com](http://www.extron.com).

## Instrucciones de seguridad • Español

**⚠ ADVERTENCIA:** Este símbolo, , cuando se utiliza en el producto, avisa al usuario de la presencia de voltaje peligroso sin aislar dentro del producto, lo que puede representar un riesgo de descarga eléctrica.

**⚠ ATENCIÓN:** Este símbolo, , cuando se utiliza en el producto, avisa al usuario de la presencia de importantes instrucciones de uso y mantenimiento estas están incluidas en la documentación proporcionada con el equipo.

Para obtener información sobre directrices de seguridad, cumplimiento de normativas, compatibilidad electromagnética, accesibilidad y temas relacionados, consulte la Guía de cumplimiento de normativas y seguridad de Extron, referencia 68-290-01, en el sitio Web de Extron, [www.extron.com](http://www.extron.com).

## Instructions de sécurité • Français

**⚠ AVERTISSEMENT :** Ce pictogramme, , lorsqu'il est utilisé sur le produit, signale à l'utilisateur la présence à l'intérieur du boîtier du produit d'une tension électrique dangereuse susceptible de provoquer un choc électrique.

**⚠ ATTENTION :** Ce pictogramme, , lorsqu'il est utilisé sur le produit, signale à l'utilisateur des instructions d'utilisation ou de maintenance importantes qui se trouvent dans la documentation fournie avec l'équipement.

Pour en savoir plus sur les règles de sécurité, la conformité à la réglementation, la compatibilité EMI/EMF, l'accessibilité, et autres sujets connexes, lisez les informations de sécurité et de conformité Extron, réf. 68-290-01, sur le site Extron, [www.extron.com](http://www.extron.com).

## Istruzioni di sicurezza • Italiano

**⚠ AVVERTENZA:** Il simbolo, , se usato sul prodotto, serve ad avvertire l'utente della presenza di tensione non isolata pericolosa all'interno del contenitore del prodotto che può costituire un rischio di scosse elettriche.

**⚠ ATTENZIONE:** Il simbolo, , se usato sul prodotto, serve ad avvertire l'utente della presenza di importanti istruzioni di funzionamento e manutenzione nella documentazione fornita con l'apparecchio.

Per informazioni su parametri di sicurezza, conformità alle normative, compatibilità EMI/EMF, accessibilità e argomenti simili, fare riferimento alla Guida alla conformità normativa e di sicurezza di Extron, cod. articolo 68-290-01, sul sito web di Extron, [www.extron.com](http://www.extron.com).

## Instrukcje bezpieczeństwa • Polska

**⚠ OSTRZEŻENIE:** Ten symbol, , gdy używany na produkt, ma na celu poinformować użytkownika o obecności izolowanego i niebezpiecznego napięcia wewnątrz obudowy produktu, który może stanowić zagrożenie porażenia prądem elektrycznym.

**⚠ UWAGI:** Ten symbol, , gdy używany na produkt, jest przeznaczony do ostrzegania użytkownika ważne operacyjne oraz instrukcje konserwacji (obsługi) w literaturze, wyposażone w sprzęt.

Informacji na temat wytycznych w sprawie bezpieczeństwa, regulacji wzajemnej zgodności, zgodności EMI/EMF, dostępności i Tematy pokrewne, zobacz Extron bezpieczeństwa i regulacyjnego zgodności przewodnik, część numer 68-290-01, na stronie internetowej Extron, [www.extron.com](http://www.extron.com).

## Инструкция по технике безопасности • Русский

**⚠ ПРЕДУПРЕЖДЕНИЕ:** Данный символ, , если указан на продукте, предупреждает пользователя о наличии неизолированного опасного напряжения внутри корпуса продукта, которое может привести к поражению электрическим током.

**⚠ ВНИМАНИЕ:** Данный символ, , если указан на продукте, предупреждает пользователя о наличии важных инструкций по эксплуатации и обслуживанию в руководстве, прилагаемом к данному оборудованию.

Для получения информации о правилах техники безопасности, соблюдении нормативных требований, электромагнитной совместимости (ЭМП/ЭДС), возможности доступа и других вопросах см. руководство по безопасности и соблюдению нормативных требований Extron на сайте Extron: [www.extron.com](http://www.extron.com), номер по каталогу - 68-290-01.

## 安全说明 • 简体中文

**警告:** ⚠️ 产品上的这个标志意在警告用户, 该产品机壳内有暴露的危险电压, 有触电危险。

**注意:** ⚠️ 产品上的这个标志意在提示用户, 设备随附的用户手册中有重要的操作和维护(维修)说明。

关于我们产品的安全指南、遵循的规范、EMI/EMF 的兼容性、无障碍使用的特性等相关内容, 敬请访问 Extron 网站, [www.extron.com](http://www.extron.com) 参见 Extron 安全规范指南, 产品编号 68-290-01。

## 安全記事 • 繁體中文

**警告:** ⚠️ 若產品上使用此符號, 是為了提醒使用者, 產品機殼內存在未隔離的危險電壓, 可能會導致觸電之風險。

**注意:** ⚠️ 若產品上使用此符號, 是為了提醒使用者, 設備隨附的用戶手冊中有重要的操作和維護(維修)說明。

有關安全性指導方針、法規遵守、EMI/EMF 相容性、存取範圍和相關主題的詳細資訊, 請瀏覽 Extron 網站:[www.extron.com](http://www.extron.com) 然後參閱《Extron 安全性與法規遵守手冊》, 準則編號 68-290-01。

## 安全上のご注意 • 日本語

**警告:** この記号 ⚠️ が製品上に表示されている場合は、筐体内に絶縁されていない高電圧が流れ、感電の危険があることを示しています。

**注意:** この記号 ⚠️ が製品上に表示されている場合は、本機の取扱説明書に記載されている重要な操作と保守(整備)の指示についてユーザーの注意を喚起するものです。

安全上のご注意、法規遵守、EMI/EMF適合性、その他の関連項目については、エクストロンのウェブサイト [www.extron.com](http://www.extron.com) より『Extron Safety and Regulatory Compliance Guide』(P/N 68-290-01) をご覧ください。

## 안전 지침 • 한국어

**경고:** 이 기호 ⚠️가 제품에 사용될 경우, 제품의 인클로저 내에 있는 접지되지 않은 위험한 전류로 인해 사용자가 감전될 위험이 있음을 경고합니다.

**주의:** 이 기호 ⚠️가 제품에 사용될 경우, 장비와 함께 제공된 책자에 나와 있는 주요 운영 및 유지보수(정비) 지침을 경고합니다.

안전 가이드라인, 규제 준수, EMI/EMF 호환성, 접근성, 그리고 관련 항목에 대한 자세한 내용은 Extron 웹 사이트([www.extron.com](http://www.extron.com))의 Extron 안전 및 규제 준수 안내서, 68-290-01 조항을 참조하십시오.

## Copyright

© 2021 Extron. All rights reserved. [www.extron.com](http://www.extron.com)

## Trademarks

All trademarks mentioned in this guide are the properties of their respective owners.

The following registered trademarks (®), registered service marks (SM), and trademarks (TM) are the property of RGB Systems, Inc. or Extron (see the current list of trademarks on the [Terms of Use](http://www.extron.com) page at [www.extron.com](http://www.extron.com)):

Registered Trademarks (®)
Extron, Cable Cubby, ControlScript, CrossPoint, DTP, eBUS, EDID Manager, EDID Minder, eLink, Flat Field, FlexOS, Glitch Free, Global Configurator, Global Scripiter, GlobalViewer, Hideaway, HyperLane, IP Intercom, IP Link, Key Minder, LinkLicense, LockIt, MediaLink, MediaPort, NAV, NetPA, PlenumVault, PoleVault, PowerCage, PURE3, Quantum, ShareLink, Show Me, SoundField, SpeedMount, SpeedSwitch, StudioStation, System <i>INTEGRATOR</i> , TeamWork, TouchLink, V-Lock, VideoLounge, VN-Matrix, VoiceLift, WallVault, WindoWall, XPA, XTP, XTP Systems, and ZipClip
Registered Service Mark (SM) : S3 Service Support Solutions
Trademarks (TM)
AAP, AFL (Accu-RATE Frame Lock), ADSP (Advanced Digital Sync Processing), AVEdge, CableCover, CDRS (Class D Ripple Suppression), Codec Connect, DDSP (Digital Display Sync Processing), DMI (Dynamic Motion Interpolation), Driver Configurator, DSP Configurator, DSVP (Digital Sync Validation Processing), EQIP, Everlast, FastBite, Flex55, FOX, FOXBOX, IP Intercom HelpDesk, MAAp, MicroDigital, Opti-Torque, PendantConnect, ProDSP, QS-FPC (QuickSwitch Front Panel Controller), Room Agent, Scope-Trigger, SIS, Simple Instruction Set, Skew-Free, SpeedNav, Triple-Action Switching, True4K, True8K, Vector™ 4K, WebShare, XTRA, and ZipCaddy

## FCC Class A Notice

This equipment has been tested and found to comply with the limits for a Class A digital device, pursuant to part 15 of the FCC rules. The Class A limits provide reasonable protection against harmful interference when the equipment is operated in a commercial environment. This equipment generates, uses, and can radiate radio frequency energy and, if not installed and used in accordance with the instruction manual, may cause harmful interference to radio communications. Operation of this equipment in a residential area is likely to cause interference. This interference must be corrected at the expense of the user.

## Battery Notice

This product contains a battery. **Do not open the unit to replace the battery.** If the battery needs replacing, return the entire unit to Extron (for the correct address, see the Extron Warranty section on the last page of this guide).

**CAUTION:** Risk of explosion. Do not replace the battery with an incorrect type. Dispose of used batteries according to the instructions.

**ATTENTION :** Risque d'explosion. Ne pas remplacer la pile par le mauvais type de pile. Débarrassez-vous des piles usagées selon le mode d'emploi.

## Class 1 Laser Product

Any service to this product must be carried out by Extron and its qualified service personnel.

**CAUTION:** Using controls, making adjustments, or performing procedures in a manner other than what is specified herein may result in hazardous radiation exposure.

**NOTE:** For more information on safety guidelines, regulatory compliances, EMI/EMF compatibility, accessibility, and related topics, see the “[Extron Safety and Regulatory Compliance Guide](#)” on the Extron website.

## Produit laser de classe 1

Si ce produit a besoin d'un quelconque entretien, celui-ci doit être fait par Extron et son personnel qualifié.

**ATTENTION :** L'utilisation de commandes, la réalisation de réglages, ou l'exécution de procédures de manière contraire aux dispositions établies dans le présent document, présente un risque d'exposition dangereuse aux radiations.

**Remarque :** Pour plus d'informations sur les directives de sécurité, les conformités de régulation, la compatibilité EMI/EMF, l'accessibilité, et les sujets en lien, consultez le « [Informations de sécurité et de conformité Extron](#) » sur le site internet d'Extron.

## Conventions Used in this Guide

### Notifications

The following notifications are used in this guide:

**DANGER:**

- Will result in serious injury or death.
- Entraînera des blessures graves ou la mort.

**WARNING:** Potential risk of severe injury or death.**AVERTISSEMENT :** Risque potentiel de blessure grave ou de mort.**CAUTION:**

Risk of minor personal injury.

**ATTENTION :**

Risque de blessure mineure.

**ATTENTION:**

- Risk of property damage.
- Risque de dommages matériels.

**NOTE:** A note draws attention to important information.**TIP:** A tip provides a suggestion to make working with the application easier.

### Software Commands

Commands are written in the fonts shown here:

```
^AR Merge Scene, ,0p1 scene 1,1 ^B 51 ^W^C.0  
[01] R 0004 00300 00400 00800 00600 [02] 35 [17] [03]  
Esc [X1] * [X17] * [X20] * [X23] * [X21] CE ←
```

**NOTE:** For commands and examples of computer or device responses used in this guide, the character “0” is the number zero and “O” is the capital letter “o.”

Computer responses and directory paths that do not have variables are written in the font shown here:

```
Reply from 208.132.180.48: bytes=32 times=2ms TTL=32  
C:\Program Files\Extron
```

Variables are written in slanted form as shown here:

```
ping xxx.xxx.xxx.xxx -t  
SOH R Data STX Command ETB ETX
```

Selectable items, such as menu names, menu options, buttons, tabs, and field names are written in the font shown here:

From the **File** menu, select **New**.  
Click the **OK** button.

### Specifications Availability

Product specifications are available on the Extron website, [www.extron.com](http://www.extron.com).

### Extron Glossary of Terms

A glossary of terms is available at <http://www.extron.com/technology/glossary.aspx>.



# Contents

---

## **Introduction ..... 1**

About this Guide.....	1
Product Description.....	1
Fiber Cable Transmission Modes .....	2
Extron LinkLicense.....	3
Features .....	3

---

## **Installation and Operation..... 5**

Installation Overview .....	5
Rear Panel Features .....	5
Rear Panel Connections .....	5
Connector and Cable Details.....	10
HDMI Connectors.....	10
RS-232 and IR.....	11
TP Cable Termination and Recommendations .....	11
Front Panel Features.....	12
Operation .....	12
Reset.....	12
Configuration.....	14
EDID.....	14
HDCP.....	14
RS-232 Insertion.....	15
Audio Configuration.....	16
Audio Embedding.....	16
Audio Input Gain.....	16
Audio Input Configuration .....	16
Audio Mute.....	16

---

## **SIS Configuration and Control ..... 17**

Host Control Ports.....	17
Rear Panel RS-232 Port .....	17
Front Panel Configuration USB Port.....	17
Ethernet (LAN) Ports.....	17
Establishing a Connection.....	18

Simple Instruction Set Control .....	19
Host-to-Unit Instructions.....	19
Device-Initiated Power-Up Message .....	19
Error Responses.....	19
Timeout .....	19
Using the Command and Response Table .....	20
Common symbol definitions.....	20
Command and Response Table for SIS Commands .....	22

---

## **Configuration Software ..... 26**

Software/Firmware Installation .....	26
Connecting to PCS.....	28
Device Discovery Panel.....	28
TCP/IP Panel.....	29
Offline Device Preview.....	29
Software Overview.....	30
Software Menu .....	31
Device Menu.....	33

---

## **Internal Web Page ..... 35**

Accessing the Internal Web Page .....	35
Web Page Panels .....	36
Device Info Panel.....	36
Device Status Panel.....	37
Network Settings Panel .....	37
Firmware Panel.....	38
Roles and Permissions Panel.....	39
LinkLicense Panel.....	40
About the FOX3 T 201 .....	41

---

## **Equipment Mounting ..... 42**

Mounting the Transmitter .....	42
Tabletop Use .....	42
Mounting kits.....	42
UL Rack-Mounting Guidelines .....	42



# Introduction

**⚠ WARNING:** The FOX3 T 201 output continuous invisible light (Class 1 rated), which may be harmful to the eyes; use with caution.

**AVERTISSEMENT :** Le FOX3 T 201 émet une lumière invisible en continu (conforme à la classe 1) qui peut être dangereux pour les yeux, à utiliser avec précaution.

- Do not look into the rear panel fiber optic cable connectors or into the fiber optic cables themselves.
- Ne regardez pas dans les connecteurs de câble fibre optique sur le panneau arrière ou dans les câbles fibre optique eux-mêmes.
- Plug the attached dust cap into the optical transceiver when the fiber optic cable is unplugged.
- Branchez la protection contre la poussière dans l'ensemble émetteur/récepteur lorsque le câble fibre optique est débranché.

## About this Guide

This guide contains information about the Extron FOX3 T 201 fiber optic transmitter.

## Product Description

The FOX3 T 201 transmitter is a ultra-high performance fiber optic extender for long haul transmission of the following over two fiber optic cables (see [figure 1](#) on page 2):

- Uncompressed or visually lossless HDCP-compliant 4096x2160 or 3840x2160 (UHD) @ 60 Hz video HDMI video
- 2-CH LPCM audio
- RS-232 and IR control signals

The transmitter extends HDMI signals up to:

- 20 km (12.4 miles) for the singlemode cables
- 500 m (1640 feet) with 50 µm OM4 4700 MHz bandwidth laser optimized multimode cables

(see [Fiber Cable Transmission Modes](#) on page 2).

The transmitter converts the HDMI video, the selected audio, and the RS-232 serial communication into two proprietary data streams and outputs them as optical signals via fiber optic small form factor pluggable (SFP) modules on two LC connector to a compatible Extron FOX3 fiber optic receiver.

The transmitter has many controls, including audio adjustments, that are available under Remote RS-232 and USB port Simple Set Instruction (SIS) control and PCS.

**NOTE:** The FOX3 products are **not** compatible with legacy FOX, FOXBOX, FOX II, PowerCage 401 FOX, or PowerCage 1600 FOX products.

## Fiber Cable Transmission Modes

The transmitter is further categorized by the type of fiber optic cable, multimode or singlemode, which defines the effective range of transmission:

**Multimode** — Long distance, up to 500 m (1640 feet) (depending on the fiber cable)

**Singlemode** — Very long distance, up to 20 km (12.4 miles)

**NOTE:** The multimode and singlemode units are physically and functionally identical, with the exception of the effective range of transmission. In this guide, any reference applies to either transmission mode unless otherwise specified.

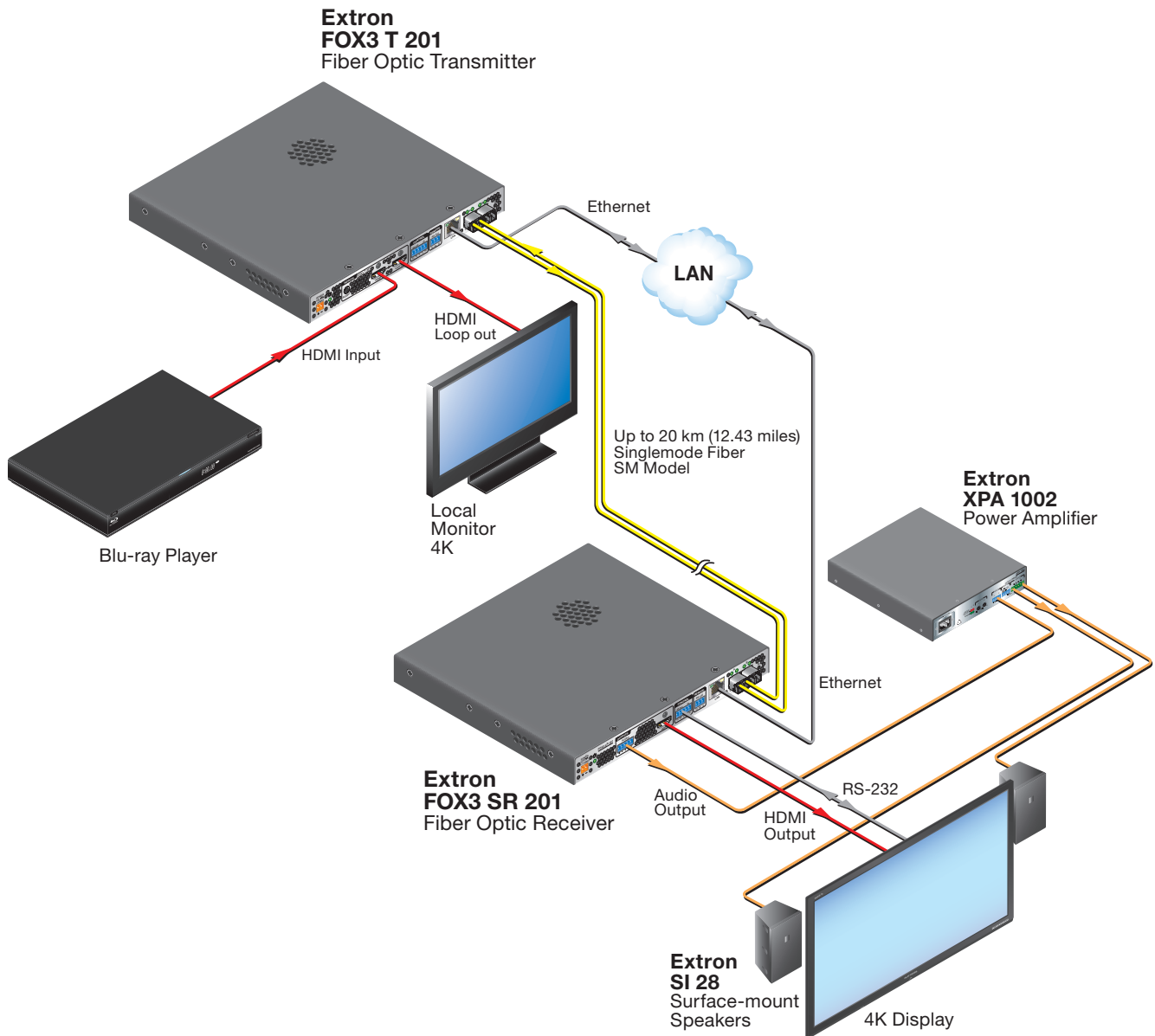

**Figure 1.** Typical FOX3 T 201 Transmitter Application

## Extron LinkLicense

An Extron LinkLicense unlocks features that add convenience, expand system options, and enhance the capabilities of Extron products. Each LinkLicense can be purchased separately from the FOX3 device and activated as the need arises (A LinkLicense can be uploaded using Extron Toolbelt software and the Toolbelt Help File. See [Software/Firmware Installation](#) on page 26 to download Toolbelt).

LinkLicense upgrades available for the FOX3 transmitter include the following:

- **Uncompressed Video Upgrade** —
  - This LinkLicense is enabled once and lasts for the life of the product.
  - Allows the FOX3 devices to pass uncompressed 4K @ 60 Hz video on the second SFP module, enabling the highest video performance.

## Features

- **Transmits HDMI video, stereo audio, RS-232 control, and IR control signals over fiber optic cabling.**
- **Supports mathematically lossless 4K video up to 4096x2160 at 60 Hz with 4:4:4 chroma sampling over one fiber.**
- **Supports uncompressed 4K video up to 4096x2160 at 60 Hz with 4:4:4 chroma sampling over two fibers.**
- **Supported HDMI 2.0 specification features include data rates up to 18 Gbps and Deep Color up to 12-bit.**
- **HDCP 2.3 compliant.**
- **Buffered HDMI input loop-through** — Local HDMI output provides signals for a local display, enabling monitoring or sharing of content without the need for a separate distribution amplifier.
- **Audio embedding** — Analog stereo audio signals are converted to digital HDMI audio.
- **User-selectable HDCP authorization** — Allows the transmitter to appear HDCP compliant or non-HDCP compliant to the connected source.
- **Key Minder continuously verifies HDCP compliance for quick, reliable switching** — Authenticates and maintains continuous HDCP encryption between input and output devices to ensure quick and reliable switching in professional AV environments.
- **EDID Minder automatically manages EDID communication between connected devices** — EDID Minder ensures that all sources power up properly and reliably output content for display.
- **Audio gain and attenuation adjustment capability** — Setting the level of gain or attenuation eliminates noticeable volume differences when switching between sources.
- **Bidirectional RS-232 and IR signal transmission over fiber optic cabling for AV device control** — Bidirectional RS-232 and IR control pass-through enables a remote device to be controlled without the need for additional cabling. Two fibers are required for bidirectional communications.
- **LinkLicense Support** — Extron LinkLicense unlocks features that add convenience, expand system functionality, and enhance the capabilities of Extron products.
- **Front panel USB configuration port** — Enables easy system configuration without having to access the rear panel.
- **Ethernet monitoring and control** — Enables control and proactive monitoring over a LAN, WAN, or the Internet.

- **RS-232 control** — Features an RS-232 serial port for control and configuration.
- **Real-time status LED indicators for troubleshooting and monitoring** — Front and rear panel LEDs verify signal presence, HDCP authentication, fiber link status, and power.
- **Easy setup and commissioning with Extron's PCS - Product Configuration Software** — Conveniently configures multiple products using a single software application.
- **Internal color bars test pattern for calibration and setup** — Simplifies setup and installation by providing a video signal when a source is unavailable.
- **Compatible with Extron FOX3 Series matrix switchers** — Creates HDCP-compliant signal distribution systems.
- **JITC Certified** — Successfully completed interoperability and information assurance testing for use in government applications and other mission-critical environments.
- **Industry standard LC connectors provide reliable physical connectivity and precise fiber core alignment.**
- **Available as an 850 nm multimode model for moderate-range transmissions up to 500 m (1640 feet) and a 1310 nm singlemode model for extreme distances up to 20 km (12.4 miles).**
- **1" (2.5 cm) high, half rack width mountable metal enclosure.**
- **External Extron Everlast power supply** — Provides worldwide power compatibility, with high demonstrated reliability and low power consumption for reduced operating cost.
- **Extron Everlast Power Supply is covered by a 7-year parts and labor warranty.**

# Installation and Operation

This section details the installation of the FOX3 T 201 transmitter, including:

- [Installation Overview](#)
- [Rear Panel Features](#)
- [Connector and Cable Details](#)
- [Front Panel Features](#)
- [Operation](#)
- [Audio Configuration](#)

## Installation Overview

Follow these steps to install and set up an Extron FOX3 T 201 transmitter for operation:

- Turn off all of the equipment. Ensure that the video source and the output display are all turned off and disconnected from the power source.
- Mount the transmitter (see [Equipment Mounting](#) on page 42).
- Connect the cables and configure the units (see “Rear Panel Connections”, starting below).
- Plug in the power supplies, then turn on the display and the input.

## Rear Panel Features

### Rear Panel Connections

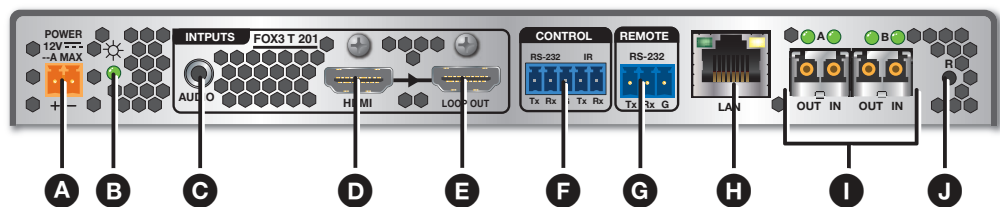

**Figure 2. FOX3 T 201 Transmitter Rear Panel Features**

- |                        |                                 |
|------------------------|---------------------------------|
| <b>A</b> Power inlet   | <b>F</b> Control RS-232/IR port |
| <b>B</b> Power LED     | <b>G</b> Remote RS-232          |
| <b>C</b> Audio input   | <b>H</b> LAN Ethernet port      |
| <b>D</b> HDMI input    | <b>I</b> SFP module and LEDs    |
| <b>E</b> HDMI Loop Out | <b>J</b> Reset button           |

- A** **Power inlet** (see **figure 2** on page 5) — Connect the external 12 V, 2.0 A power supply to the 2-pole captive screw inlet.

**CAUTION:** The DC output cables must be kept separate from each other while the power supply is plugged in. Remove power before wiring

**ATTENTION :** Les câbles de sortie CC doivent être séparés les uns des autres tant que la source d'alimentation est branchée. Coupez l'alimentation avant d'effectuer les raccordements.

**ATTENTION:**

- Do not connect any external power supplies until you have read the Attention notifications starting below.
- Veuillez lire les encadrés « Attention » à partir ci-dessous avant de brancher une source d'alimentation externe.

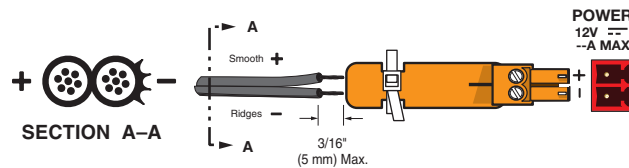

**Figure 3. Power Connector Wiring**

1. Cut the DC output cord to the length needed.
2. Strip the jacket to expose 3/16 inch (5 mm) of the conductor wire (see figure 3).
3. Ensure the connections have the correct polarity as shown in the figure above. The wire with ridges is the ground wire.
4. Slide the exposed ends of the wire into the captive screw connector and secure by tightening the screws.
5. Use the supplied tie wrap to strap the power cord to the extended tail of the connector.

**ATTENTION:**

- The length of the exposed wires in the stripping process is important. The ideal length is 3/16 inches (5 mm). Any longer and the exposed wires may touch, causing a short circuit between them. Any shorter and the wires can be easily pulled out even if tightly fastened by the captive screws.
- La longueur des câbles exposés est importante lorsque l'on entreprend de les dénuder. La longueur idéale est de 5 mm (3/16 inches). S'ils sont trop longs, les câbles exposés pourraient se toucher et provoquer un court-circuit. S'ils sont trop courts, ils peuvent être tirés facilement, même s'ils sont correctement serrés par les borniers à vis.
- Do not tin the wire leads before installing into the connector. Tinned wires are not as secure in the connector and could be pulled out. They may also break after being bent several times.
- Ne pas étamer les conducteurs avant de les insérer dans le connecteur. Les câbles étamés ne sont pas aussi bien fixés dans le connecteur et pourraient être tirés. Ils peuvent aussi se casser après avoir été pliés plusieurs fois.

**ATTENTION:**

- Always use a power supply provided by or specified by Extron. Use of an unauthorized power supply voids all regulatory compliance certification and may cause damage to the supply and the end product.
  - Utilisez toujours une source d'alimentation fournie ou recommandée par Extron. L'utilisation d'une source d'alimentation non autorisée annule toute certification de conformité réglementaire, et peut endommager la source d'alimentation et l'unité.
- 
- If not provided with a power supply, this product is intended for use with a UL Listed power source marked "Class 2" or "LPS" rated 12 VDC, 2.0 A minimum.
  - Si le produit n'est pas fourni avec une source d'alimentation, il doit être utilisé avec une source d'alimentation certifiée UL de classe 2 ou LPS avec une tension nominale de 12 Vcc, 2.0 A minimum.
- 
- Unless otherwise stated, the AC/DC adapters are not suitable for use in air handling spaces or in wall cavities.
  - Sauf mention contraire, les adaptateurs CA/CC ne conviennent pas à une utilisation dans les espaces d'aération ou dans les cavités murales.
- 
- The installation must always be in accordance with the applicable provisions of National Electrical Code ANSI/NFPA 70, article 725 and the Canadian Electrical Code part 1, section 16. The power supply shall not be permanently fixed to building structure or similar structure.
  - Cette installation doit toujours être conforme aux dispositions applicables du Code américain de l'électricité (National Electrical Code) ANSI/NFPA 70, article 725, et du Code canadien de l'électricité, partie 1, section 16. La source d'alimentation ne devra pas être fixée de façon permanente à une structure de bâtiment ou à une structure similaire.
- 
- Power supply voltage polarity is critical. Incorrect voltage polarity can damage the power supply and the unit. The ridges on the side of the cord identify the power cord negative lead (see **figure 3** on page 6).
  - La polarité de la source d'alimentation est primordiale. Une polarité incorrecte pourrait endommager la source d'alimentation et l'unité. Les stries sur le côté du cordon permettent de repérer le pôle négatif du cordon d'alimentation (voir **figure 3**).
- 
- To verify the polarity before connection, plug in the power supply with no load and check the output with a voltmeter.
  - Pour vérifier la polarité avant la connexion, brancher l'alimentation hors charge et mesurer sa sortie avec un voltmètre.

**B Power LED** — The lit LED indicates power is applied and device is ready to transmit.

- C Audio input** (see [figure 2](#) on page 5)— Connect an audio input device to the Audio 3.5 mm audio jack.

**NOTE:** The analog audio input on this connector is in addition to the digital audio embedded in the HDMI inputs. See [figure 4](#) to identify the connector tip, ring, and sleeve when making connections for the transmitter from existing audio cables. A mono audio connector consists of the tip and sleeve. A stereo audio connector consists of the tip, ring, and sleeve.

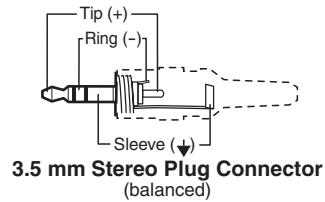

**Figure 4. Audio Wiring Diagram**

- D HDMI input** — Connect a digital video input to this HDMI port. The transmitter also accepts embedded digital audio on this port (see [HDMI Connectors](#) on page 10 to use the included Extron Lock-It Lacing Bracket).
- E HDMI Loop Out** — If desired, connect a local monitor to this HDMI port.
- F Control RS-232 and IR port** — Connect a serial RS-232 signal, a modulated or unmodulated IR signal, or both to this 3.5 mm, 5-pole captive screw port for bidirectional RS-232 and IR communication (see [RS-232 and IR](#) on page 11 to wire the connector).

**NOTES:**

- To receive responses from the controlled device over RS-232 or IR, two fiber optic cables must be connected.
- The FOX3 system can pass RS-232 commands and responses at rates up to 115200 baud.
- RS-232 and IR can be active simultaneously.

- G Remote RS-232 port** — For serial control of the transmitter, connect a host device, such as a computer or touch panel control, via the 3-pole captive screw port (see [RS-232 and IR](#) to wire this connector).
- H LAN Ethernet port** — Connect the transmitter to an Ethernet LAN or WAN via this RJ-45 port. Ethernet control allows the operator to configure the transmitter from a remote location. When connected to an Ethernet LAN or WAN, the transmitter can be accessed and operated from a computer running a standard Internet browser (see [TP Cable Termination and Recommendations](#) on page 11 to wire the connector).
- **Link (green) LED** — Indicates that the unit is properly connected to an Ethernet LAN. This LED should light steadily.
  - **Act (yellow) LED** — Indicates transmission of data packets on the RJ-45 connector. This LED should blink as the unit communicates.

**NOTE:** This is not a pass-through LAN connection

❶ **SFP module and LEDs** — (see [figure 2](#) on page 5)

**⚠ WARNING:** The units output continuous invisible light (Class 1 rated), which may be harmful to the eyes; use with caution. Plug the attached dust cap into the optical transceiver when the fiber optic cable is unplugged.

**AVERTISSEMENT :** Le produit émet une lumière invisible en continu (conforme à la classe 1) qui peut être dangereux pour les yeux, à utiliser avec précaution. Branchez la protection contre la poussière dans l'ensemble émetteur/récepteur lorsque le câble fibre optique est débranché.

**NOTES:**

- Ensure the proper fiber cables for the transmitter and receiver pair are used. Typically, singlemode fiber has a yellow jacket and multimode cable has an orange or aqua jacket.
- See figure 5 for fiber cable connections. Connect the transmitter to a receiver in one of three ways:
  - One way (transmitter to receiver) only, connect transmitter Outputs A (❶) to receiver Inputs A (❶).
  - Two way (transmitter to receiver and return), connect transmitter Outputs A (❶) to receiver Inputs A (❶) and connect transmitter Outputs A (❷) to receiver Inputs A (❷).
  - Output B is available to transmit a 4K @ 60 Hz uncompressed signal when the FOX3 4K @ 60 Hz Uncompressed Video LinkLicense is purchased.

❶ **Port A Out (required)** — For all one-way video, audio, and serial communications from the transmitter to the receiver, connect a fiber optic cable to the Out LC port.

Connect the opposite end of this fiber optic cable to the Port A In LC port on the receiver or to any other compatible Extron FOX3 device.

❷ **Port A In (optional)** — For one-way serial communications from the receiver to the transmitter, connect a fiber optic cable to the In LC port.

Connect the opposite end of this fiber optic cable to the Port A Out LC port on a receiver or to any other compatible Extron FOX3 device.

**SFP Link LEDs** —

- Transmit Optical OUT LED lights solid green when powered and lights off when there is no power on the endpoint.
- Receive Optical IN LED lights solid green when light is present and lights off when there is no power or light present.

❷ **Reset button** — Initiates three levels of resets (1, 4, and 5). Use a pointed stylus, ballpoint pen, or small screwdriver to access the recessed button (see [Reset](#) on page 12 for detailed reset information).

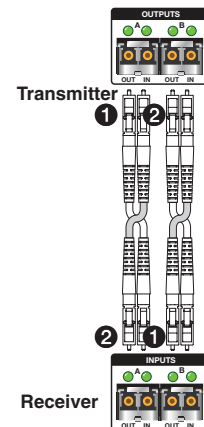

**Figure 5. Connection**

## Connector and Cable Details

### HDMI Connectors

HDMI signals run at a very high frequency and are especially prone to errors caused by bad video connections, too many adapters, or excessive cable length. To avoid the loss of an image or jitter, follow these guidelines:

- Limit or avoid the use of adapters.
- Use only cables specifically intended for HDMI or DVI signals.

To securely fasten an HDMI cable to a device:

1. Plug the HDMI cable into the panel connection (see figure 6, **1**).

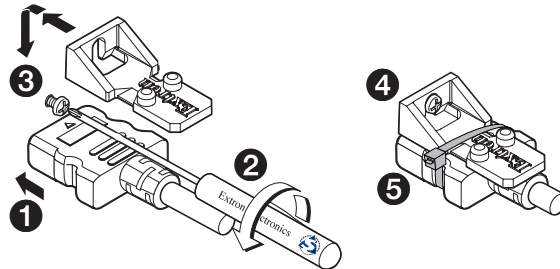

**Figure 6. Installing the LockIt Lacing Bracket**

2. Loosen the HDMI connection mounting screw from the panel enough to allow the LockIt lacing bracket to be placed over it (**2**). The screw does not have to be removed.
3. Place the LockIt lacing bracket on the screw and against the HDMI connector, then tighten the screw to secure the bracket (**3**).

#### **ATTENTION:**

- Do not overtighten the HDMI connector mounting screw. The shield to which it fastens is very thin and can easily be stripped.
- Ne serrez pas trop la vis de montage du connecteur HDMI. Le blindage auquel elle est attachée est très fin et peut facilement être dénudé.

4. Loosely place the included tie wrap around the HDMI connector and the LockIt lacing bracket (**4**).
5. While holding the connector securely against the lacing bracket, use pliers or similar tools to tighten the tie wrap, then remove any excess length (**5**).

## RS-232 and IR

Figure 7 shows how to wire the Control (RS-232 and IR) connector.

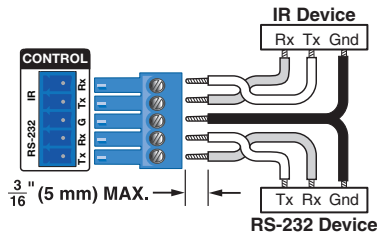

**Figure 7. Control and Sync Connectors Wiring**

**NOTE:** The IR Tx and Rx line pair and the RS-232 Tx and Rx line pair must each cross once between this connector and the source or destination.

## TP Cable Termination and Recommendations

It is vital that your Ethernet cable be the correct cable type and that it be properly terminated with the correct pinout. Ethernet links use Category (CAT) 3, 5e, or CAT 6, unshielded twisted pair (UTP) or shielded twisted pair (STP) cables, terminated with RJ-45 connectors. Ethernet cables are limited to a length of 328 feet (100 meters).

**NOTES:**

- Do not use standard telephone cables. Telephone cables do not support Ethernet or Fast Ethernet.
- Do not stretch or bend cables. Transmission errors can occur.

The cable used depends on your network speed. The unit supports 10 Mbps (10Base-T — Ethernet), 100 Mbps (100Base-T — Fast Ethernet), and 1000 Mbps (1000Base-T — IEEE 802.3ab) half-duplex and full-duplex Ethernet connections.

- 10Base-T Ethernet requires CAT 3 UTP or STP cable at minimum.
- 100Base-T Fast Ethernet requires CAT 5e UTP or STP cable at minimum.
- 1000Base-T Gigabit Ethernet requires CAT 5, CAT 5e, CAT 6, or CAT 7 UTP or STP cable.

The Ethernet cable must be terminated as a patch (straight-through) cable and must be properly terminated in accordance with the **TIA/EIA T568-B** wiring standard (see figure 8).

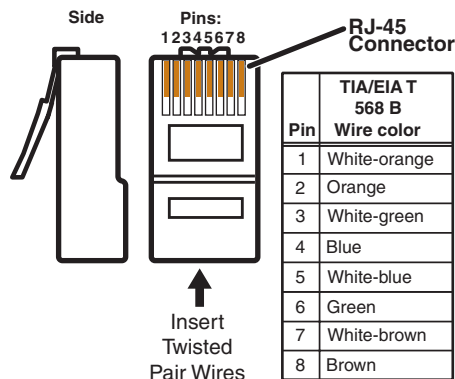

**Figure 8. RJ-45 Connector and Pinout Tables**

## Front Panel Features

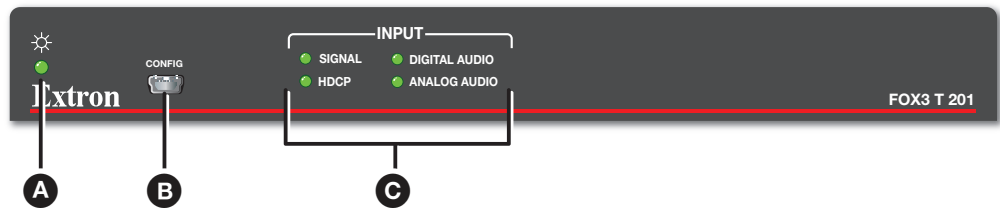

**Figure 9. Transmitter Front Panel Features**

- A Power LED** — The unit is receiving power and is operational.
- B Configuration port** — This USB mini-B port is used to configure the unit and to update firmware.
- C Input LEDs**
  - **Signal** — Lights when the unit detects an input video signal.
  - **HDCP** — Lights when the input signal is HDCP encrypted.
  - **Digital Audio** — Lights when digital audio is selected.
  - **Analog Audio** — Lights when analog audio input is selected.

## Operation

After the transmitter, receiver, and the connected devices are powered up, the system is fully operational. If any problems are encountered, ensure all cables are routed and connected properly.

**NOTE:** Ensure that the video source and display are properly connected to the FOX3 transmitter and receiver, and power is applied to the FOX3 devices and the display **before** power is applied to the video source. If the other devices are not turned on before the video source, the image may not appear.

Configuration and operation of the transmitter is accomplished via [SIS Configuration and Control](#) starting on page 17, the [Internal Web Page](#) starting on page 35, and [Configuration Software](#) starting on page 26.

## Reset

The rear panel **Reset** button initiates three levels of resets (numbered 1, 4, and 5). Use a pointed stylus, ballpoint pen, or small screwdriver to access the recessed button.

See the [Reset Modes](#) and [figure 10](#) on page 13 for a summary of the resets.

**ATTENTION:**

- Review the reset modes carefully. Some reset modes delete all user loaded content and revert the device to default configuration.
- Analysez minutieusement les différents modes de réinitialisation. Certains modes de réinitialisation suppriment l'intégralité du contenu chargé de l'utilisateur et remettent l'appareil au mode de configuration par défaut.

Perform resets of the unit as follows (see figure 10):

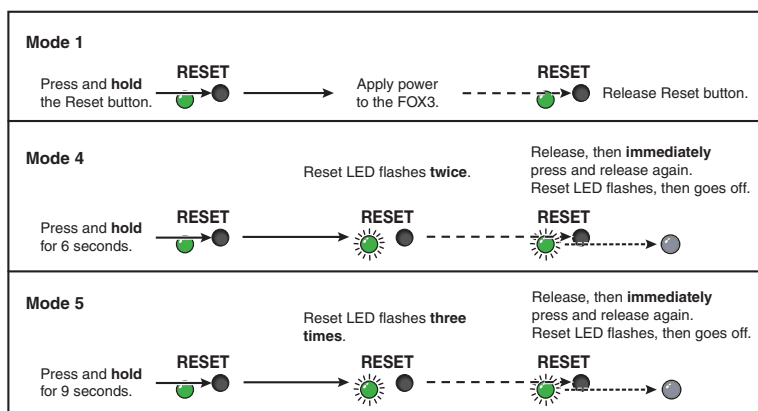

**Figure 10. Resets**

Reset Modes				
	Mode	Activation	Result	Purpose and Notes
Use Factory Firmware	1	Hold in the recessed rear panel <b>Reset</b> button while applying power to the unit.	The device reverts to the factory default firmware for a single power cycle.	Use to revert to the factory default firmware for a single power cycle if incompatibility issues arise with user-loaded firmware. All user files and settings are maintained.
	<p><b>NOTE:</b> Do not operate with the default firmware loaded by a mode 1 reset. Use it only to load the most current firmware to the device.</p>			
Reset All IP Settings	*4	Hold in the <b>Reset</b> button until the <b>Power</b> LED blinks twice (once at 3 seconds, again at 6 seconds). Then, release and press the <b>Reset</b> button again within 1 second*.	Sets the following back to factory default: <ul style="list-style-type: none"> <li>• Port mapping</li> <li>• IP address (192.168.254.254)</li> <li>• Subnet mask address (255.255.255.0)</li> <li>• Gateway address (0.0.0.0)</li> </ul> Turns DHCP off. The <b>Power</b> LED blinks four times.	Use to reset all IP settings back to factory defaults.  Equivalent to SIS command 1ZQQQ (see <a href="#">Resets</a> on page 24).
Reset to Factory Defaults	*5	Hold in the <b>Reset</b> button until the <b>Power</b> LED blinks three times (once at 3 seconds, again at 6 seconds, again at 9 seconds). Then, release and press the <b>Reset</b> button again within 1 second*.	A complete reset to factory defaults (except the firmware): <ul style="list-style-type: none"> <li>• Does everything mode 4 does.</li> <li>• Clears port configurations.</li> <li>• Resets all IP options.</li> <li>• Clears all user settings.</li> <li>• Resets all passwords.</li> <li>• Clears all files from the unit.</li> <li>• The <b>Power</b> LED blinks four times.</li> </ul>	Use to start over with default configuration and uploading, and also to replace events.  Equivalent to SIS command ZQQQ (see <a href="#">Resets</a> ).
<p><b>NOTES:</b></p> <ul style="list-style-type: none"> <li>• *For modes 4 and 5, nothing happens if the momentary press does not occur within 1 second.</li> <li>• The factory configured passwords for all accounts on this device have been set to the device serial number. In the event of a complete system reset, the passwords revert to the default, which is <b>extron</b> (see <a href="#">Roles and Permissions Panel</a> on page 39 to change a password).</li> </ul>				

## Configuration

**NOTE:** Transmitters can be configured via PCS (see the *FOX3 T 201 PCS Help File*) and SIS commands (see **SIS Configuration and Control** starting on page 17). Product help files are available in PCS when a device is connected or an offline device is selected.

### EDID

The FOX3 uses EDID Minder, which ensures that a source device connected to the transmitter input continuously sees the EDID of a sink device, even if the sink is not physically connected. By default, the EDID is set to 1080p @ 60 Hz with 2-channel audio. There is one slot to upload custom EDID to the device.

Use PCS to upload EDID to the device (see the *FOX3 T 201 PCS Help File*).

### HDCP

#### Input

The HDMI input negotiates and authenticates HDCP with the source device if the source requires HDCP encryption. The authentication process is repeated whenever the stored EDID is changed or updated, which is indicated by pulling HPD low.

HDCP support can be disabled for each input independently using SIS command (see **HDCP authorized device** on page 25) or PCS (see the *FOX3 T 201 PCS Help File*).

#### Outputs

The output is pre-authenticated and encrypted, in accordance with the configured HDCP output mode using PCS (see the *FOX3 T 201 PCS Help File*).

If an output requires encryption, but the connected sink device cannot be authenticated, that output displays a green screen.

#### HDCP output modes

- **Follow Input** (default) — Output authentication and encryption follows input status. Authentication times out after ~10 seconds.
- **Always Encrypt Output** — The output is always authenticated and encrypted. Authentication times out after ~10 seconds.
- **Follow Input (with continuous trials)** — Output authentication and encryption follows input status with no authentication timeout.
- **Always Encrypt Output (with continuous trials)** — The output is always authenticated and encrypted with no authentication timeout.
- **Disable Authentication** — The output is never authenticated or encrypted. When an HDCP encrypted input signal is detected, the display always shows a green screen.

## RS-232 Insertion

A user can connect a control system to send and receive RS-232 data over the fiber and the captive screw port of the transmitter and receiver.

### Captive Screw Insertion

A user can connect an RS-232 signal from a control system to an endpoint and pass that signal over the fiber to the connected endpoint. An RS-232 signal must be inserted in the RS-232 port on the transmitter or receiver and bidirectional fiber must be used.

The RS-232 signal settings are:

- Baud rate: 9600 (default) to 115200
- Stop bits: 1 (default) to 2
- Data bits: 5 to 8 (default)
- Parity: Odd, Even, or None (default)

The RS-232 insertion method must be set to Captive Screw Insertion via PCS (see the *FOX3 SR 201 Help File*) on both endpoints passing the control signal.

Example of a bidirectional fiber system (see figure 11):

- On the FOX3 transmitter and receiver, configure the RS-232 Insertion via PCS.
- The control system then sends a control command:
  - Into the transmitter Control RS-232 port.
  - Out of the transmitter SFP A port to the receiver SFP A IN port.
  - To the receiver captive screw port.
  - Into the display to take some action.
- The response from the display is sent back to the control system.

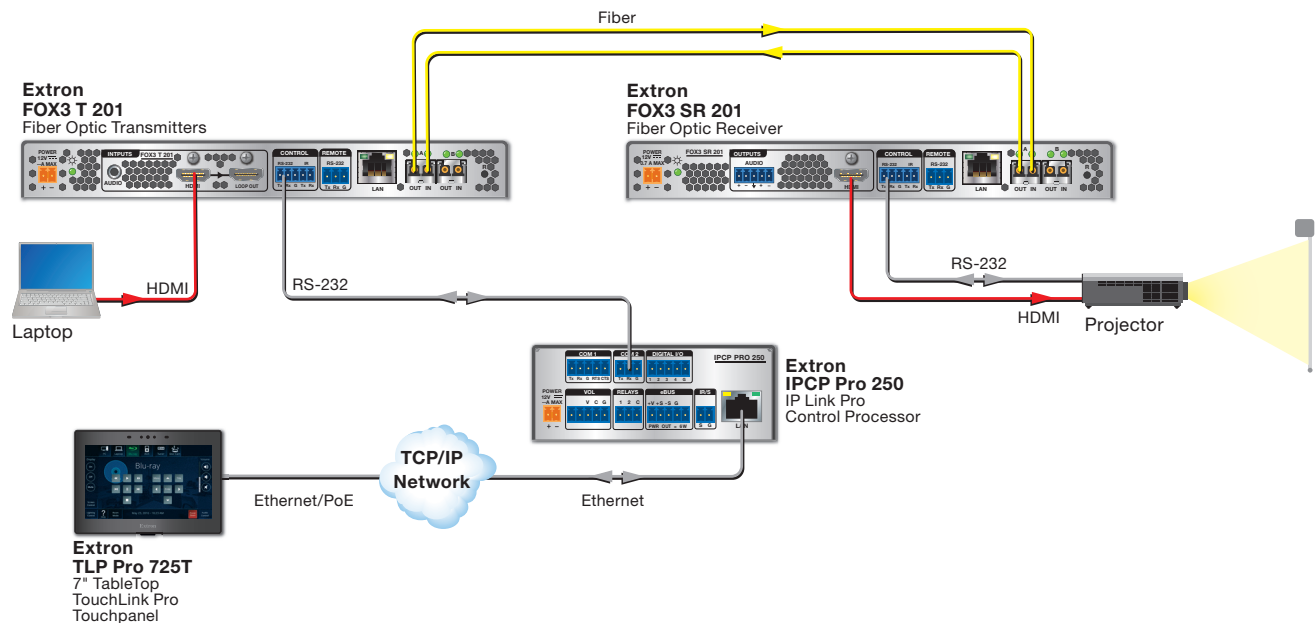

Figure 11. Typical Captive Screw Insertion Configuration

## Audio Configuration

### Audio Embedding

The FOX3 supports a single audio signal to pass LPCM-2CH. The audio input sent over the fiber output can be configured via PCS (see the *FOX3 T 201 PCS Help File*) or SIS command (see [Input audio selection](#) on page 25). Select digital, analog, or auto.

### Audio Input Gain

Adjust the transmitter gain level for the analog audio input via PCS (see the *FOX3 T 201 PCS Help File*). The analog audio input can be adjusted from -18 dB to +24 dB in 1 dB steps.

### Audio Input Configuration

Select the audio on the input of the transmitter via PCS (see the *FOX3 T 201 PCS Help File*) or SIS command (see [Input audio selection](#)).

The audio input options are:

- **Auto** (default) — The transmitter selects between digital and analog audio based on the digital audio input signal.
  - Digital audio is selected when embedded audio is present on the HDMI input.
  - Analog audio is selected when digital audio is not detected.
- **Force Digital** — Digital embedded audio is passed to the local HDMI and fiber output.
- **Force Analog** — Analog audio is passed to the local HDMI and fiber output.

### Audio Mute

Mute audio on the Loop Out, HDMI output, and analog audio output individually via PCS (see the *FOX3 T 201 PCS Help File*) or SIS commands (see [Audio mute — Digital Output or Analog Audio Out](#) on page 22).

# SIS Configuration and Control

This section describes the remote control operation of the FOX3 T 201 transmitter, including:

- **Host Control Ports**
- **Simple Instruction Set Control**
- **Command and Response Table for SIS Commands**

The FOX3 transmitter can be configured using SIS commands, PCS, or embedded web pages. The FOX3 transmitter can be controlled using SIS commands or PCS. Configure and control the FOX3 transmitter remotely via a host computer or other device (such as a control system) by connecting to the rear panel RS-232 port, LAN port, or the front panel USB port.

## Host Control Ports

### Rear Panel RS-232 Port

The rear panel serial port (see [figure 2, G](#) on page 5) can be connected to a host device such as a computer running Extron DataViewer, available at [www.extron.com](http://www.extron.com). The port makes serial control of the FOX3 device possible. Use the protocol information listed below to make the connection.

The protocol for the serial ports is as follows:

- 9600 baud
- no parity
- 8 data bits
- 1 stop bit
- no flow control

### Front Panel Configuration USB Port

The front panel mini B USB Configuration port (see [figure 9, B](#) on page 12) can be connected to a host computer for configuration using SIS commands via an SSH client and IP address 203.0.113.22 on port 22023.

### Ethernet (LAN) Ports

The rear panel Ethernet connector (see [figure 2](#) on page 5) can be connected to an Ethernet LAN or WAN. Communications between the transmitter and the controlling device is via an SSH client using port 22023. This connection makes SIS control of the unit possible using a computer connected to the same LAN or WAN (see [TP Cable Termination and Recommendations](#) on page 11 to wire the LAN connector).

## Default IP address

To access the FOX3 transmitter via the LAN port, the IP address, subnet mask, and the gateway address for the devices are needed. If the addresses have not been changed, the factory-specified defaults are:

- **IP address** 192.168.254.254
- **Gateway address** 0.0.0.0
- **Subnet mask** 255.255.255.0

## Establishing a Connection

Establish a network connection to a FOX3 device as follows:

1. Download the SSH client software from the internet.
2. Open the SSH client software.
3. Enter the IP address of the FOX3 device in the **Host Name or IP address** field.

**NOTE:** If the local system administrators have not changed the value, the default IP address is 192.168.254.254.

4. Enter **22023** in the **Port** field.
5. The FOX3 device is password protected, so the appropriate administrator or user name and password must be entered.
  - If the login and password are correct, the device responds with a copyright message including the copyright year, the name of the product, firmware version, part number, and the current date and time.
  - If the login and password are incorrect, the **Login as** prompt returns. Enter the administrator or user name and password again.

### NOTES:

- The FOX3 device is shipped password-protected. The factory configured passwords for all accounts on this device have been set to the device serial number.
- In the event of a complete system reset, the password converts to the default, which is **extron**. New passwords must be configured to secure the device.
- On password-protected connections, there are two levels of protection: administrator and user. Administrators have full access to all editing functions.

## Using verbose mode

SSH connections to a FOX3 device can be used to monitor for changes that occur on the device, such as SIS commands from other SSH sockets or a serial port. For an SSH session to receive change notices from the device, the SSH session must be in verbose mode 1 or 3 (see the SIS command **Verbose mode** on page 23).

# Simple Instruction Set Control

## Host-to-Unit Instructions

SIS commands consist of one or more characters per field. No special characters are required to begin or end a command character sequence. When a command is valid, the transmitter executes the command and sends a response to the host device. All responses from the transmitter to the host end with a carriage return and a line feed (CR/LF = **↵**), which signals the end of the response character string. A string is one or more characters.

## Device-Initiated Power-Up Message

When the device completes its start-up, it issues the following message to the host:

© Copyright 20yy, Extron FOX3 T 201 MM (SM), Vx.xx, 60-nnnn-nn

- 20yy is the copyright year
- Vx.xx is the firmware version number
- 60-nnnn-nn is the part number.

**NOTE:** This message only displays if the FOX3 device is connected to the serial port.

## Error Responses

When the transmitter receives a valid SIS command, it executes the command and sends a response to the host device. If the transmitter is unable to execute the command because the command is invalid or it contains invalid parameters, the transmitter returns an error response to the host. The error response codes are:

- E10 — Invalid command
- E11 — Invalid preset number
- E13 — Invalid parameter
- E14 — Invalid for this configuration
- E17 — Invalid command for signal type
- E18 — System or command timed out
- E21 — Invalid room number
- E22 — Busy
- E24 — Privilege violation
- E25 — Device not present
- E26 — Maximum number of connections exceeded
- E28 — Bad file name or file not found

## Timeout

Pauses of 10 seconds or longer between command ASCII characters result in a timeout. The command operation is aborted with no other indication.

## Using the Command and Response Table

The command and response table begins below. Symbols are used throughout the table to represent variables in the command and response fields. Command and response examples are shown throughout the table. The ASCII to HEX conversion table below is for use with the command and response table.

ASCII to Hex Conversion Table																Esc	1B	CR	0D	LF	0A	
Space →	20	!	21	"	22	#	23	\$	24	%	25	&	26	'	27							
	(	28	)	29	*	2A	+	2B	,	2C	-	2D	.	2E	/	2F						
	0	30	1	31	2	32	3	33	4	34	5	35	6	36	7	37						
	8	38	9	39	:	3A	;	3B	<	3C	=	3D	>	3E	?	3F						
	@	40	A	41	B	42	C	43	D	44	E	45	F	46	G	47						
	H	48	I	49	J	4A	K	4B	L	4C	M	4D	N	4E	O	4F						
	P	50	Q	51	R	52	S	53	T	54	U	55	V	56	W	57						
	X	58	Y	59	Z	5A	[	5B	\	5C	]	5D	^	5E	_	5F						
	`	60	a	61	b	62	c	63	d	64	e	65	f	66	g	67						
	h	68	i	69	j	6A	k	6B	l	6C	m	6D	n	6E	o	6F						
	p	70	q	71	r	72	s	73	t	74	u	75	v	76	w	77						
	x	78	y	79	z	7A	{	7B		7C	}	7D	~	7E	DEL	7F						

**NOTE:** For commands and examples of computer or device responses used in this guide, the character “0” is the number zero and “O” is the capital letter “o.”

## Common symbol definitions

↵ = Carriage return/line feed

• = Space

← or | = Carriage return (no line feed)

Esc or W = Escape key

X1 = Video mute

X2 = Audio output

X3 = Audio mute status

X4 = Input video signal status

X5 = Input audio status

X6 = Input HDCP status

X7 = Output HDCP status

X8 = Input audio selected

X9 = Device type

X10 = Enable DHCP

X11 = IP address, subnet,  
gateway address

X12 = Baud rate

X13 = Parity

X14 = Data bits

X15 = Stop bits

X16 = UARTs

0 = Unmute (**default**) 1 = Mute video only  
2 = Mute video and sync

1 = Digital (Tx Loop Out)  
3 = All outputs

0 = Unmute (**default**), 1 = Mute

0 = Not detected, 1 = Detected

0 = Not detected, 1 = Detected

0 = No source detected

1 = Source with HDCP detected (**default**)

2 = Source with no HDCP present

0 = No active sink detected

1 = Sink detected, output signal encrypted

2 = Sink detected, output signal not encrypted

0 = Auto 1 = Digital 2 = Analog

TX or RX

0 = Off (**default**) 1 = On

xxx.xxx.xxx.xxx

300 – 115200 baud (9600 **default**)

odd, even, none (**default**), mark, space  
(only the first letter required)

7, 8 (**default**)

1 (**default**), 2

1 = Endpoint

<b>X17</b> = Verbose mode	0 = Clear/none ( <b>default for Ethernet</b> ) 1 = Verbose mode ( <b>default for RS-232</b> ) 2 = Tagged response for queries 3 = Verbose mode and tagged responses for queries
<b>X18</b> = Active fiber link	1 = SFP A      2 = SFP B
<b>X19</b> = Input HDCP Authorization	0 = HDCP authorized off    1 = HDCP authorized on ( <b>default</b> )
<b>X20</b> = Resolution and refresh rate	<i>nnnnHorizontalxnnnnVertical@xxHz</i> (example: 3840x2160@59.9Hz) (0000x0000@000Hz = no input detected)
<b>X21</b> = Detected audio input format	0 = Not detected    1 = Digital    2 = Analog
<b>X22</b> = Detected Video input color space format	0 = Not detected    1 = YUV    2 = RGB
<b>X23</b> = Detected pixel clock	4-digit response with 0 padding (example: 297 = 0297MHZ) (0000 = No pixel clock detected)
<b>X28</b> = Fiber link detection	0 = Not Detected      2 = Detected
<b>X29</b> = Fiber optic mode	SM or MM
<b>X30</b> = Enable or Disable Echo	0 = Disabled      2 = Enabled ( <b>default</b> )
<b>X31</b> = Timeout	The number of seconds before timeout on IP connections (min=1, max=65000, with each number equivalent to 10 seconds [default=30=300 seconds])
<b>X32</b> = Force 4K60 compressed mode	0 = Disable ( <b>default</b> ; after a reset, setting defaults back to 0) 1 = Force 4K60 on 1 fiber
<b>X33</b> = View audio output	1 = Digital    2 = Analog
<b>X34</b> = Enable Telnet port 23	0 = Off ( <b>default</b> )    23 = Telnet port 23 enabled
<b>X35</b> = Port number	Response is 5 digits with leading zeros, for example 00000 or 00023



Command Function	SIS Command (Host to Unit)	Response (Unit to Host)	Additional description
<b>Information requests (continued)</b>			
Information request	I	SFPALnk[X28]•SFPBLnk[X28]•SigI[X4]•HdcpI[X6]•HdcpO[X7]•AudI[X8]•X9•X29←	
Verbose mode 2/3:		Inf00*SFPALnk[X28]•SFPBLnk[X28]•SigI[X4]•HdcpI[X6]•HdcpO[X7]•AudI[X8]•X9•X29←	
		Response description: Fiber link A•Fiber link B•Signal input•Input HDCP•Output HDCP•Input audio•Transmitter•Fiber mode←	
Example:	I	SFPALnk1•SFPBLnk1•SigI1•HdcpI1•HdcpO1•AudI1•TX•SM←	Signals are detected on the two fiber links, a signal is detected on the input, the input and output are HDCP devices, the digital audio input is selected, the device is a transmitter, and the fiber mode is singlemode.
<b>KEY:</b>			
	X4 = Input video signal status	0 = Not detected	1 = Detected
	X6 = Input HDCP status	0 = No source detected	1 = Source with HDCP detected (default)
		2 = Source with no HDCP present	
	X7 = Output HDCP status	0 = No active sink detected	1 = Sink detected, output signal encrypted
		2 = Sink detected, output signal not encrypted	
	X8 = Input audio selection	0 = Auto	1 = Digital      2 = Analog
	X9 = Device type	TX or RX	
	X28 = Fiber link detection	0 = Not detected	1 = Detected
	X29 = Fiber optic mode	SM or MM	
View LinkLicense	EscLELIC←	FOX3 Uncompressed Video, 79-2560-01←←	If LinkLicense is not installed, returns ←←
<b>DHCP client</b>			
Set DHCP on or off	EscX10DH←	IdhX10←	
View DHCP status	EscDH←	X10←	
<b>KEY:</b>			
	X10 = Set DHCP	0 = Off (default)	1 = On
<b>Telnet port</b>			
Set Telnet port map	EscZX34PMAP←	PmapZX35←	Sets Telnet port map to X34.
View Telnet port map	EscZPMAP←	X35←	
<b>KEY:</b>			
	X34 = Enable Telnet port 23	0 = Off (default)	23 = Telnet port 23 enabled
	X35 = Port number	Response is 5 digits with leading zeros, for example 00000 or 00023	
<b>Echo for SIS over SSH (port 22023)</b>			
Enable Echo	Esc1ECHO←	Echo1←	Returns command entered with response.
Disable Echo	Esc0ECHO←	Echo0←	Returns response only.
View Echo status	EscECHO←	X30←	
<b>NOTE:</b> This command is only applicable to the SIS over SSH connection using the LAN or USB ports. The echo setting is for the current connection only, and remains until the connection is closed. Apply after connection is established.			
<b>KEY:</b>			
	X30 = Enable or disable Echo	0 = Disable	1 = Enable (default)
<b>Verbose mode</b>			
Set verbose mode	EscX17CV←	VrbX17←	
View verbose mode	EscCV←	X17←	
<b>NOTE:</b> Verbose mode reverts back to default in the event of a power cycle, disconnect from dataviewer, or disconnect from the Ethernet.			
<b>KEY:</b>			
	X17 = Verbose mode	0 = Clear/none (default for Ethernet)	1 = Verbose mode (default for RS-232)
		2 = Tagged response for queries	3 = Verbose mode and tagged responses for queries



Command Function	SIS Command (Host to Unit)	Response (Unit to Host)	Additional description
<b>HDCP authorized device</b>			
Set HDCP authorized device on	<b>Esc</b> E1HDCP←	HdcpE1←	
Set HDCP authorized device off	<b>Esc</b> E0HDCP←	HdcpE0←	
View HDCP authorized device	<b>Esc</b> EHDCP← Verbose mode 2/3:	<b>X19</b> ← HdcpE <b>X19</b> ←	<b>Default:</b> HDCP authorized on.
<b>KEY:</b> <b>X19</b> = Input HDCP Authorization      0 = HDCP authorized off      1 = HDCP authorized on ( <b>default</b> )			
<b>Input audio selection</b>			
Select audio input	<b>Esc</b> I <b>X8</b> AFMT←	AfmtI <b>X8</b> ←	<b>Default.</b> Digital has priority.
View selected audio input	<b>Esc</b> IAFMT←	<b>X8</b> ←	
<b>KEY:</b> <b>X8</b> = Input audio selection      0 = Auto ( <b>default</b> )      1 = Digital      2 = Analog			
<b>Input signal detection information</b>			
View detected input signal information	35I/i Verbose mode 2/3:	Res <b>X20</b> •AudI <b>X21</b> •VcsI <b>X22</b> •Pixcl <b>X23</b> ← Inf35*Res <b>X20</b> •AudI <b>X21</b> •VcsI <b>X22</b> •Pixcl <b>X23</b> ←	
<b>KEY:</b> <b>X19</b> = Input HDCP Authorization      0 = HDCP authorized off      1 = HDCP authorized on ( <b>default</b> ) <b>X20</b> = Resolution and refresh rate <i>nnnn</i> <sup>Horizontal</sup> <i>xnnnn</i> <sup>Vertical</sup> @xxHz (0000x0000@000Hz = no input detected) <b>X21</b> = Detected input audio format      0 = Not detected      1 = Digital      2 = Analog <b>X22</b> = Detected video input color space      0 = Not detected      1 = YUV      2 = RGB <b>X23</b> = Pixel clock (in MHz)      4-digit response with 0 padding (example: 294 = 0297MHZ) (0000 = Not detected)			
<b>Force 4K60 compressed mode</b>			
Force 4K 60 compressed mode	<b>Esc</b> C1FOX←	FoxmC1←	Sends 4K60 signal compressed on 1 fiber
Disable 4K 60 compressed mode	<b>Esc</b> C0FOX←	FoxmC0←	Sends 4K60 signal uncompressed on 2 fibers
View 4K 60 compressed mode status	<b>Esc</b> CFOX← Verbose mode 2/3:	<b>X24</b> ← FoxmC <b>X24</b> ←	
<b>NOTE:</b> This command only applies to devices with the 4K60 Uncompressed Video LinkLicense or transmitter units with part numbers ending with -13 or -14. If the command is issued to the wrong unit, return E14.			
<b>KEY:</b> <b>X24</b> = Force 4K60 compressed mode      0 = Disable ( <b>default</b> ; after a reset, setting defaults back to 0)      1 = Force 4K60 on 1 fiber			

# Configuration Software

The FOX3 201 transmitter can be easily configured using Extron Product Configuration Software (PCS). This section describes the software installation and communication (see the *FOX3 T 201 PCS Help File* for detailed control information). The topics covered in this section are:

- [Software/Firmware Installation](#)
- [Connecting to PCS](#)
- [Software Overview](#)

## Software/Firmware Installation

Visit [www.extron.com](http://www.extron.com) to download and install the PCS software.

### NOTES:

- Also download the latest versions of software and firmware for your product.
- An Extron Insider account is required to download either firmware or software.
- Software and firmware can also be downloaded from the **Download** tab on the product web page.

1. Mouse over the **Download** link at the top of the page (see figure 12, **1**).

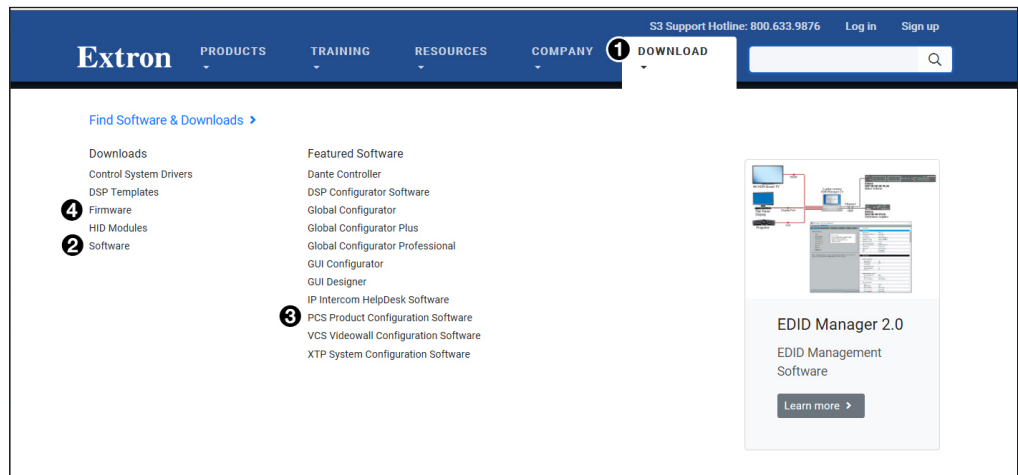

**Figure 12. Software Links on Download Screen**

2. Click the appropriate link on the drop-down list.

**For software**, either click the **Software** link (**2**) or, if the software is listed, click directly on that link (see the **PCS Product Configuration Software** link **3**) and skip to **step 5** on page 27.

**For firmware**, click the **Firmware** link (**4**).

3. If there is no direct link to your software, click the **Software** link (**2**).

4. Scroll down to the alphabetic navigation bar (see figure 13).

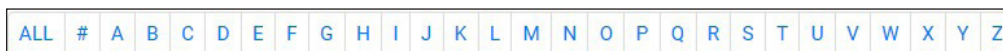

**Figure 13. Software Installation**

5. Click the appropriate letter to locate the software or firmware.
6. Click **Download** and follow the on-screen instructions (see figure 14, ❶ for PCS).

Version	Release Date	New in the Current Release	Size
4.3.0	Jul. 9, 2018	<ul style="list-style-type: none"> <li>Added support for HC 403</li> <li>Added language support for Spanish, Simplified Chinese, Japanese, German, and French</li> <li>Ability to restore configuration to multiple devices across all IN1608 products</li> </ul>	162.5 MB

❶ **Download**  
Login required

**Figure 14. PCS Software Download**

**For Firmware:**

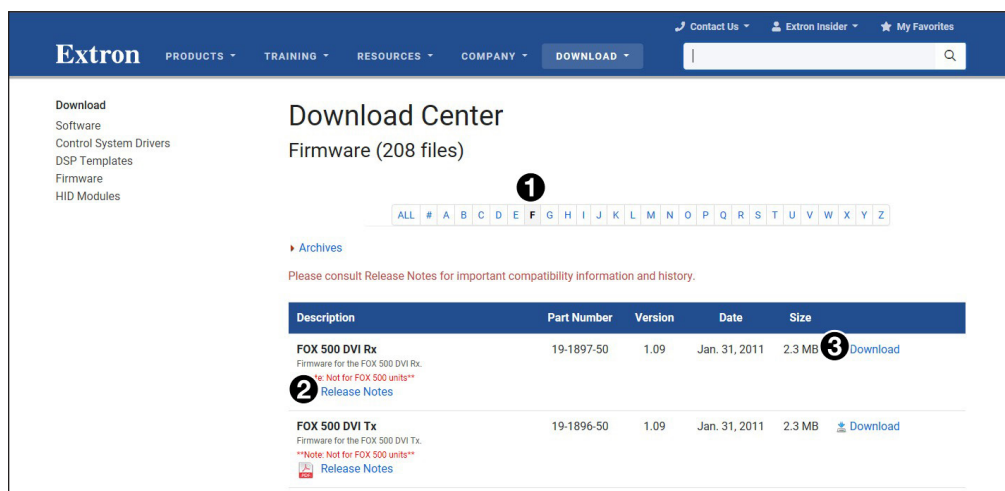

**Figure 15. Firmware Page with Alphabetic Navigation Bar**

- a. Click the letter **F** from the alphabetic navigation bar (see figure 15, ❶).
  - b. Scroll down the page to find the firmware for the FOX3 T 201.
  - c. (Optional) Click **Release Notes** (❷) for more information about the firmware update.
  - d. Click **Download** (❸). The product download screen opens.
  - e. Enter the required user information and click **Download**. An executable (.exe) file is downloaded to the PC. Run this program to place the firmware on the PC for future use. Make a note of the folder where the firmware file was saved.
7. Install the software.
    - a. Navigate to the folder where the software file was downloaded.
    - b. Double-click the executable file and follow the on-screen directions to install the software.

**For Firmware:**

- a. To install via PCS, see **Update Firmware** in the **Device Menu** on page 33.
- b. To install via the internal web pages, see the **Firmware Panel** on page 38.

## Connecting to PCS

The Extron Product Configuration Software window opens with the **Device Discovery** panel open. Connect to the device using the **Device Discovery** panel or the **TCP/IP** panel (see figure 16).

### Device Discovery Panel

The **Device Discovery** panel displays accessible Extron devices connected directly to the PC or to a LAN or WAN. Devices are identified and sorted by model, IP address, device name, or connection method.

1. Open the Product Configuration Software program from the desktop shortcut.  
The Extron PCS window opens to the **Device Discovery** panel (see figure 16).

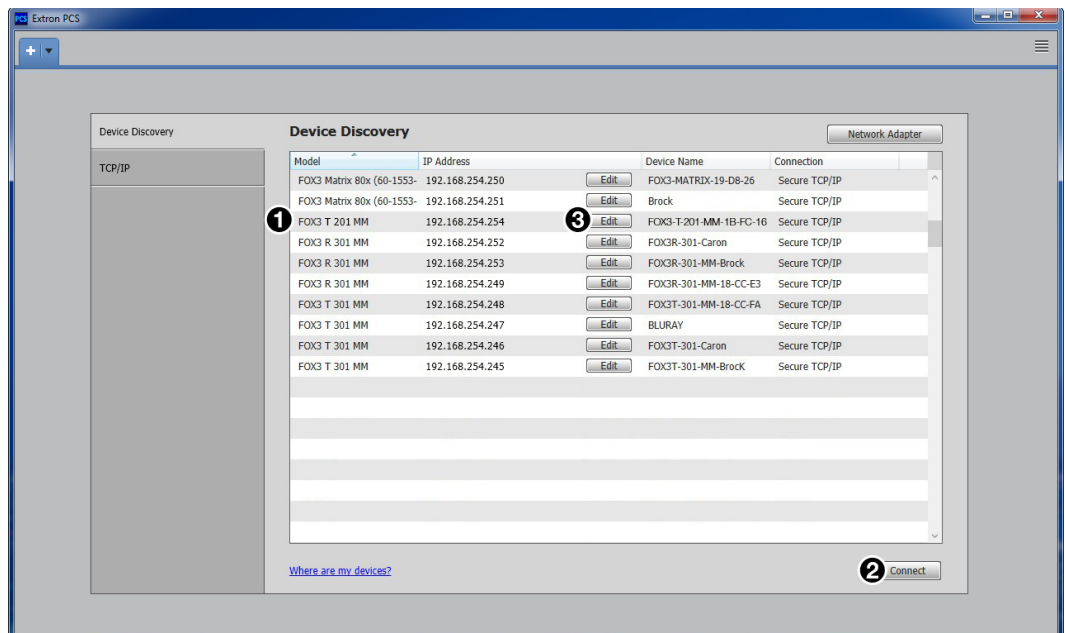

**Figure 16. Device Discovery Panel**

2. Select the FOX3 T 201 device by clicking on it to highlight it in the list (1).
3. Click **Connect** (2).

#### To edit the IP address:

1. Click on the **Edit** button (3). The **Communication Settings** box pens.
2. Click in the field to edit the address (see figure 17).
3. Click **Apply** to complete and close.

Alternatively, click **Apply and Connect** to complete and connect to the device.

Click **Cancel** to close the box without changes.

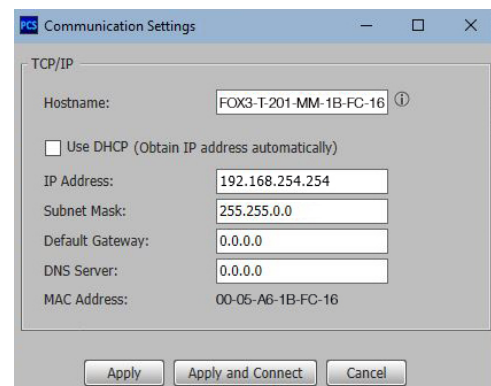

**Figure 17. Communication Settings Box**

## TCP/IP Panel

The TCP/IP panel connects PCS to a specific device through Ethernet or USB over IP.

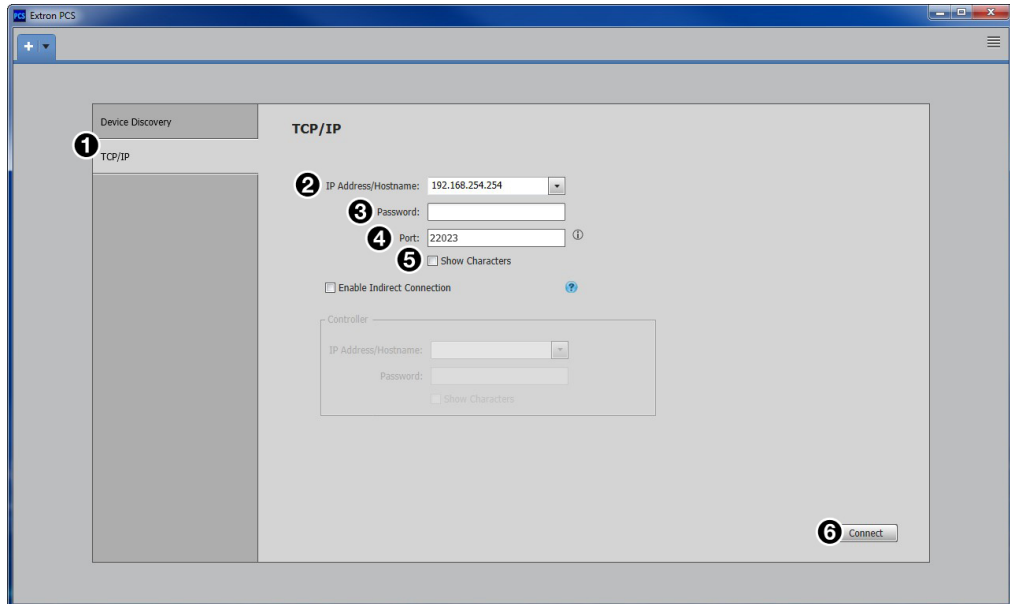

**Figure 18. Comm Port Selection Windows**

1. Click the **TCP/IP** tab (see figure 18, ①).
2. In the **IP Address/Hostname** field (②), enter the IP address of the desired device.

**NOTE:** If the IP address has not been changed, it is 192.168.254.254 for the LAN port or 203.0.113.22 for the front panel USB port.

3. In the **Password** field (③), enter the device password.

**NOTE:** The factory configured passwords for all accounts on this device have been set to the device serial number. In the event of a complete system reset, the passwords convert to the default, which is extron (see [Roles and Permissions Panel](#) on page 39 to change a password).

4. In the **Port** field (④), enter the port 22023 of the desired device.

**NOTE:** Select the **Show Characters** checkbox (⑤) to display the password characters.

5. Click the **Connect** button (⑥). A new device tab opens.

## Offline Device Preview

Opening a new device tab for an offline device displays the interface and configuration options for the device without connecting to it. However, settings cannot be changed.

**NOTE:** This is a view only mode. The FOX3 cannot be configured in this view.

**To open a scaler device tab:**

1. From the Configuration File drop-down list, select **New Configuration File** (see figure 19).

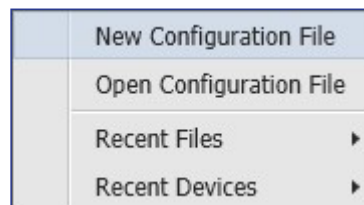

**Figure 19. Configuration File Drop-Down List**

The New Configuration File dialog box opens (see figure 20).

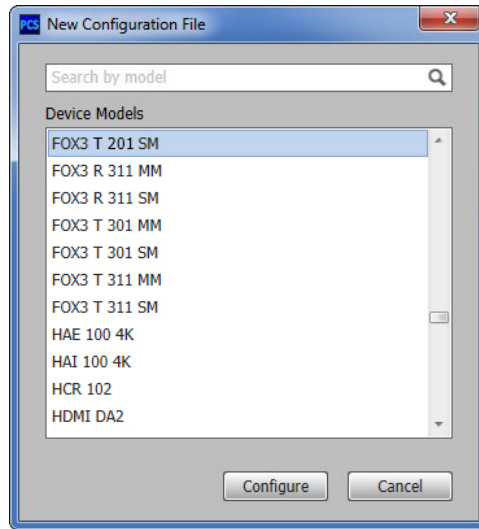
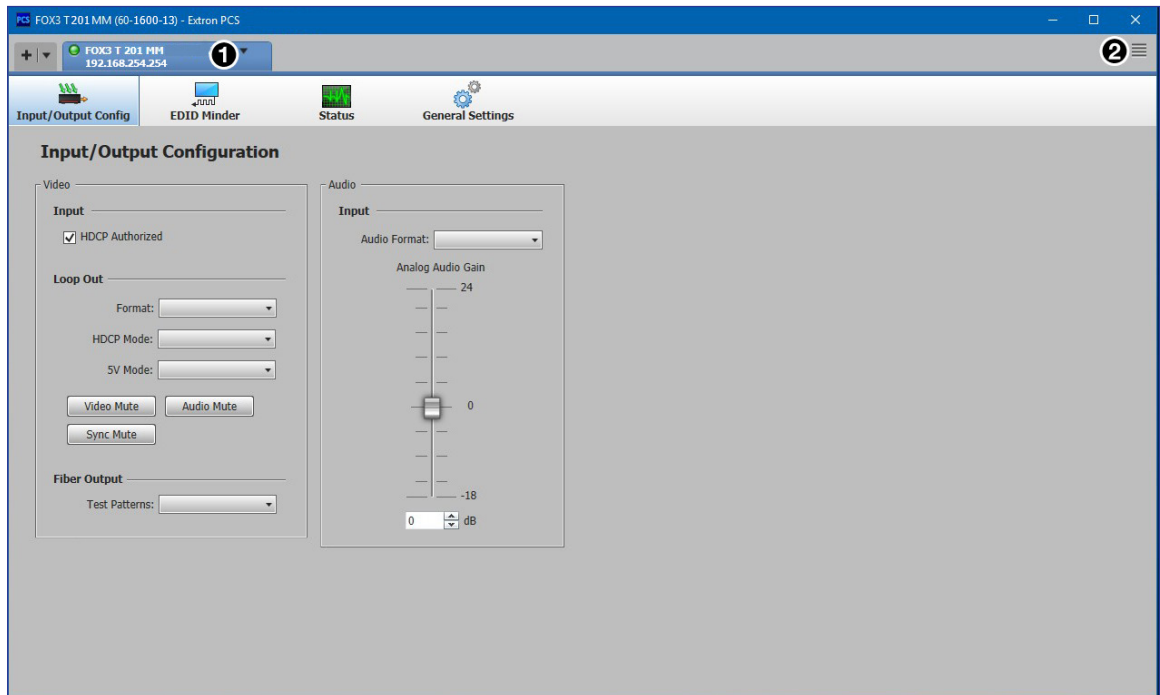

**Figure 20. New Configuration File Dialog Box**

2. Select the desired device model from the Device Models list.
3. Click the **Configure** button. A new offline device configuration tab opens.

## Software Overview

**NOTE:** For details about specific software features, see the *FOX3 T 201 PCS Help File*.

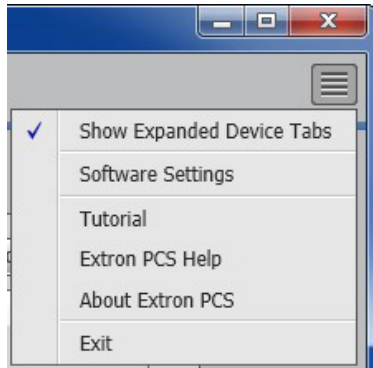

**Figure 21. FOX3 T 201 Main Window**

Each PCS screen has a **Device** drop-down list (see figure 21, ①) for device configuration options. The **Software** menu (②) contains software configuration and information options.

## Software Menu

The **Software** menu (see figure 22) contains options pertaining to PCS settings.



**Figure 22. PCS Software Menu**

### Show Expanded Device Tabs

Selecting **Show Expanded Device Tabs** from the **Software** menu displays the device IP address or connection method in the **Device** tab.

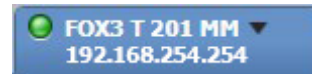
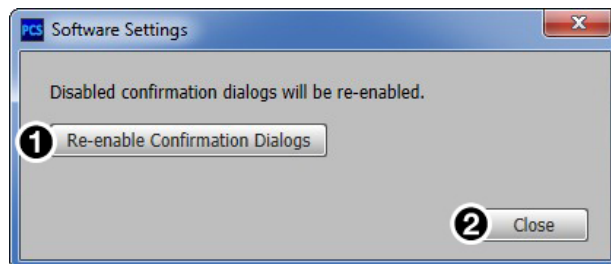

**Figure 23. Expanded Device Tab**

### Software Settings

This option resets all disabled confirmation dialogs to the default settings.

1. From the **Software** menu, select **Software Settings**. The **Software Settings** dialog box opens.



**Figure 24. Software Settings Dialog Box**

2. Click the **Re-enable Confirmation Dialogs** button (see figure 24, ①). The dialog box closes and the reset is complete.

Alternatively, click the **Close** button (②) to close the dialog box without re-enabling the confirmation dialogs.

### Tutorial

Display a general overview of where to find features in the PCS framework.

1. From the **Software** menu, select **Tutorial**. The **Tutorial** dialog box opens.
2. Click the **I Get It!** button to close the dialog box.

### Extron PCS Help

Open the PCS help file for general PCS operations.

From the **Software** menu, select **Extron PCS Help**.

## About Extron PCS

Display information about the current PCS version.

1. From the **Software** menu, select **About Extron PCS**. The **About - Extron PCS** dialog box opens.

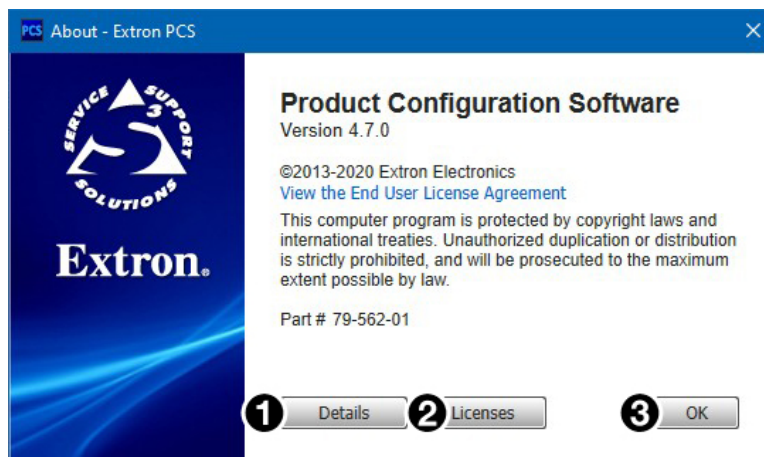

**Figure 25. About - Extron PCS Dialog Box**

2. Click the **Details** button (see figure 25, ①) for more information.
3. To display details about third-party software packages and associated licensing, click **Licenses** (②).
4. Click the **OK** button (③) to close the dialog box.

## Exit

Disconnect connected devices and close the application.

1. From the **Software** menu, select **Exit**. If device tabs are open, the **Exit** dialog box opens (see figure 26).

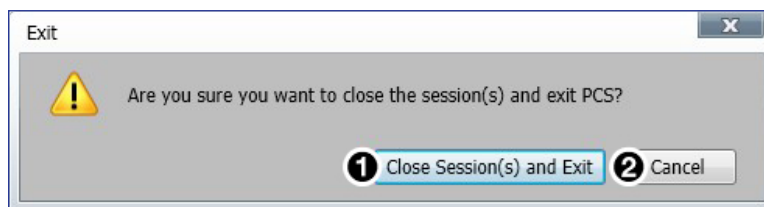
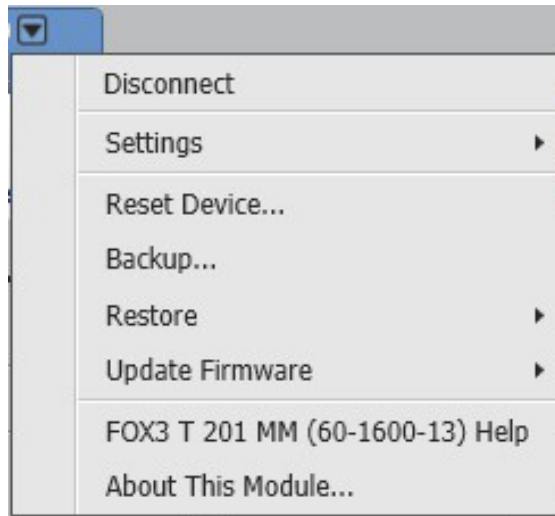

**Figure 26. Exit Dialog Box**

2. Click the **Close Session(s) and Exit** button (①) to disconnect the software from connected devices, close all offline device tabs, and close the software.  
Alternatively, click the **Cancel** button (②) to leave the software open.

## Device Menu

The **Device** menu contains options pertaining to device connection, configuration, and information. For details about all these options, see the *FOX3 T 201 PCS Help File*.



**Figure 27. Device Menu**

- **Disconnect** — Disconnect the device from the PCS program and close the **Device** tab.
- **Settings** — Open a submenu with the following options:
  - **Hardware Settings** — Display the **Hardware Settings** dialog box with device information and side tabs to change the device name, internal clock, and password of the connected device.  
  
It also contains an **Edit Communication Settings** button, which provides an alternative method of accessing the **Communication Settings** dialog box.
  - **Communication Settings** — Open the **Communication Settings** dialog box to change IP settings of the connected device.
- **Reset Device** — Open the **Reset Device** dialog box, with selectable modes for resetting the connected device, as well as the **Unit Information** (also displayed in the **Hardware Settings** dialog box).

**NOTE:** The factory configured passwords for all accounts on this device have been set to the device serial number. In the event of a complete system reset, the passwords convert to the default, which is **extron** (see **Roles and Permissions Panel** on page 39 to change a password).

- **Backup** — Export all audio, video, and communication settings of the connected device to the PC. This exported configuration can be saved as a backup file (with a .extz extension), or used to replicate settings from one device to other devices of the same model. When restoring a configuration, select specific device settings.
- **Restore** — Open a submenu containing restore options:
  - **Restore this Device** — Upload a saved configuration for a FOX3 T 201 to the connected device.
  - **Restore to Multiple Devices** — Upload a saved configuration file for an FOX3 T 201 to multiple devices on the network.

**NOTE:** The connected devices must be connected via LAN.

- **Update Firmware** — Open a submenu to upload firmware from the host device to the connected device or to multiple devices.

**NOTE:** If necessary, download new firmware from the Extron website (see [Software/Firmware Installation](#) on page 26).

- **Update Firmware to this Device...** — Upload firmware from the host device to the connected device only.
- **Update Firmware to Multiple Devices...** — Upload firmware to multiple devices on the network.

**NOTE:** The connected devices must be connected via LAN.

- **FOX3 T 201 MM (60-1600-13) Help** — Open the *FOX3 T 201 PCS Help File* in a separate window.
- **About This Module** — Open the **About This Module** dialog box, with the module part number and firmware version of the connected device.

# Internal Web Page

The FOX3 201 transmitter features an internal web server, displayed as a web page. Monitor and adjust certain settings of the FOX3 201 device via a LAN or WAN connection. Use a web browser to view the pages on a PC connected to the device LAN port or front panel USB port.

This section gives an overview of the internal web page, which is always available and cannot be erased or overwritten. Topics in this section include:

- [Accessing the Internal Web Page](#)
- [Web Page Panels](#)

## Accessing the Internal Web Page

Access the FOX3 transmitter internal web page as follows:

1. Connect the FOX3 device to a LAN or WAN using the rear panel RJ-45 LAN port or the front panel USB port (see [figure 2](#) on page 5 or [figure 9](#) on page 12).
2. Open a web browser on a PC connected on the same LAN or WAN or connected to the front panel USB port.

**NOTE:** Compatible web browsers are Microsoft® Edge®, Mozilla® Firefox®, Google Chrome™, and Apple® Safari®.

3. Enter the FOX3 transmitter IP address in the browser **Address** field.

**NOTE:** If the IP address has not been changed, it is 192.168.254.254 for the LAN port or 203.0.113.22 for the front panel USB port.

4. Press the <Enter> key on the keyboard. The web page password page opens.

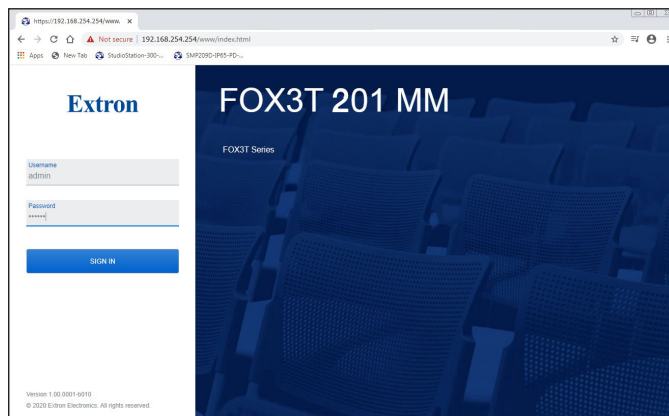

**Figure 28. Network Password Prompt**

5. The FOX3 is password protected. Enter a user name entry (**user** or **admin**) in the **Username** field and the password in the **Password** field when prompted (see figure 28).

**NOTE:** The factory configured passwords for all accounts on this device have been set to the device serial number. In the event of a complete system reset, the passwords convert to the default, which is **extron**.

6. Click the **Sign in** button, if the unit is password protected.

## Web Page Panels

The FOX3 T 201 internal web page (see figure 29) provides an overall, read-only view of the status of the transmitter, with some editable fields. Panels are:

- ❶ **Device Info Panel**
- ❷ **Device Status Panel**
- ❸ **Network Settings Panel**
- ❹ **Firmware Panel**
- ❺ **Roles and Permissions Panel**
- ❻ **LinkLicense Panel**

The panels that can be edited have an **EDIT** link to click to access the panel. To view general information about the FOX3 T 201, click the **ABOUT** link (❷ **About the FOX3 T 201**).

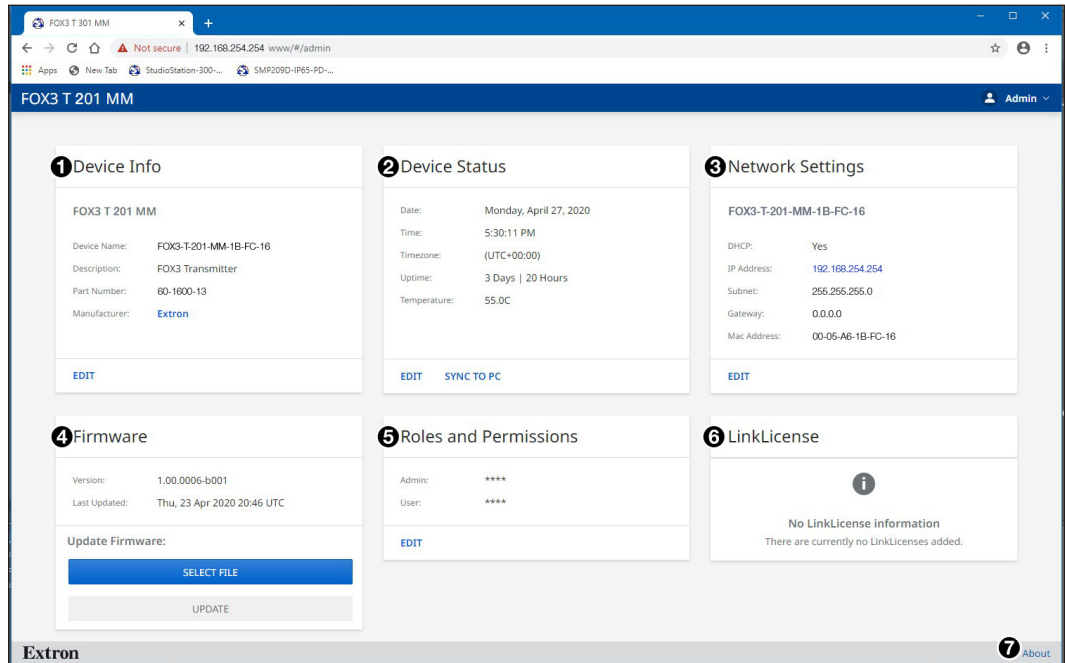

**Figure 29. FOX3 T 201 Internal Web Page**

The internal web page does not automatically update. To see an updated page, click the **Refresh** button on the web browser.

### Device Info Panel

The **Device Info** panel (see figure 29, ❶) displays the device name, a brief product description, and the part number. The panel also contains an **Extron** link, which opens the **Extron website** in a new window.

To change the name:

1. Click **EDIT** (see figure 30 [left], ❶) in the **Device Info** panel. The **Device Info Settings** panel opens to allow edits (right).



**Figure 30. Device Info Panel**

2. Edit the **Device Name** as desired.
3. When finished editing, click **SAVE** to confirm your changes or **CANCEL** to close the window without making changes. Clicking the **X** in the upper-right corner of the screen also closes the window.

## Device Status Panel

The **Device Status** panel (see [figure 29](#), ② on page 36) displays the current date, time, time zone, the amount of time the device has been running (**Uptime**), and the internal temperature in degrees Celsius.

To set the date and time:

1. Click **EDIT** (see [figure 31](#) [left], ①) in the **Device Status** panel. The **Device Status Settings** panel opens to allow edits (right).

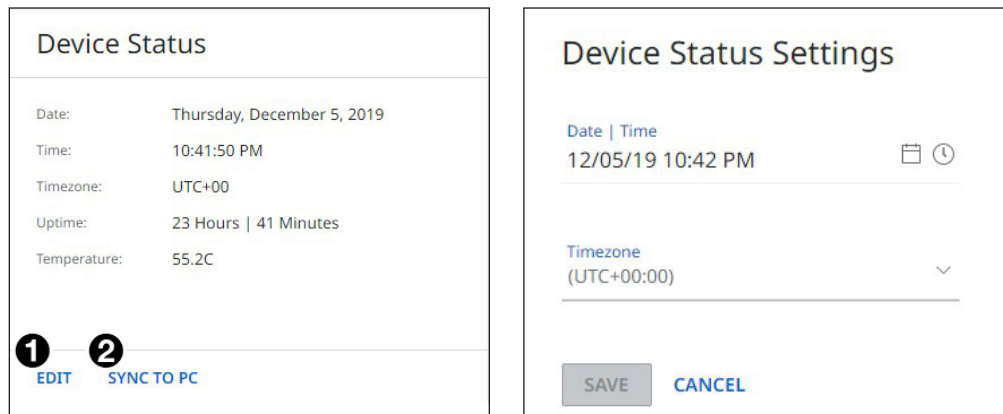

**Figure 31. Device Status Panel**

2. Edit the **Date/Time** and **Timezone** as desired.
3. When finished editing, click **SAVE** to confirm your changes or **CANCEL** to close the window without making changes. Clicking the **X** in the upper-right corner of the screen also closes the window.
4. Alternatively, click **SYNC TO PC** (②) to set the date and time according to your PC.

## Network Settings Panel

In the **Network Settings** panel (see [figure 29](#), ③ on page 36), set the IP address, subnet mask, and gateway address for your FOX3, and turn DHCP **On** and **Off**.

To set the IP addresses:

1. Click **EDIT** (see figure 32 [left], ①) in the **Network Settings** panel. The **Network Settings** panel opens to allow edits (right).

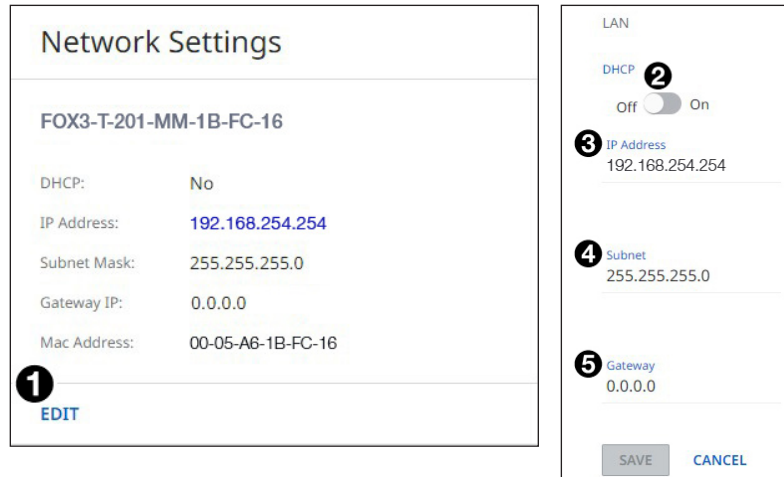

**Figure 32. Network Settings Panel**

2. Edit the network settings as desired:
  - a. Click the **DHCP** switch (②) to toggle DHCP on and off. When DHCP is enabled (On), the unit configures its IP address and other network settings from the DHCP server. The default is **Off**.
  - b. To set any of the addresses (**IP Address** (③), **Subnet** mask (④), and **Gateway** address (⑤)), click in the desired field and enter the address.
3. When finished editing, click out of the field and click **SAVE** to confirm your changes or **CANCEL** to close the window without making changes. Clicking the **X** in the upper-right corner of the screen also closes the window.

## Firmware Panel

The **Firmware** panel (see figure 29, ④) displays the current firmware version and the date it was last updated. Update the firmware on the FOX3 T 201 from this panel (see **Software/Firmware Installation** on page 26 to download the firmware files).

To update firmware:

1. In the **Firmware** panel, click the **SELECT FILE** button.
2. In the **Open** dialog box, browse to locate the new firmware file on your computer (by default the file is stored at C:\Program Files (x86)\Extron\Firmware\FOX3 T 201 after being downloaded from [www.extron.com](http://www.extron.com)).

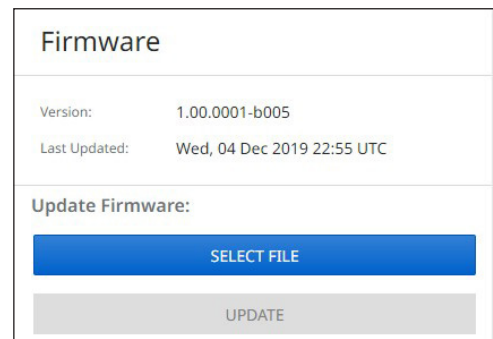

**Figure 33. Firmware Panel**

**NOTE:** Firmware files for FOX3 T 201 have a .eff extension. Do not attempt to load any other file types.

3. Double-click the firmware file name. The **Open** window closes, and the selected firmware file name appears in the **Update Firmware** panel on the web page.
4. Click **UPDATE** to begin (see figure 34). To cancel the update, click the **X** button in the **Update Firmware** panel.

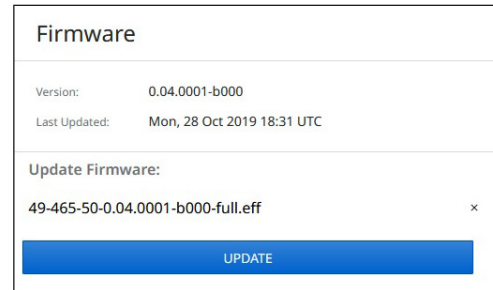

**Figure 34. Firmware Update Dialog Box**

During the updating process, a window appears in the middle of the screen,

showing messages giving the progress of the update: **Initializing**, **Installing the Firmware**, and **Rebooting Device**.

When the update is completed, the message window closes and the message **Firmware Upload Complete** appears near the top of the screen. The new firmware filename appears beside **Version** in the **Firmware** panel.

## Roles and Permissions Panel

The **Roles and Permissions** panel (see [figure 29](#), [5](#), on page 36) displays whether **Admin** and **User** passwords have been set. It does not display the actual password.

**NOTE:** The following rules apply to passwords:

- Length is 1-128 characters.
- All human-readable characters are permitted except |.
- The password cannot be a single space.
- Passwords are case-sensitive.
- If the **Admin** password is cleared, the user password is cleared as well.
- The factory configured passwords for all accounts on this device have been set to the device serial number. In the event of a complete system reset, the passwords convert to the default, which is **extron**.

To assign administrator and user passwords:

1. In the **Roles and Permissions** panel, click **EDIT** (see figure 35). The **Role and Permission Settings** dialog box opens.
2. In the **Admin** panel, click the **Change Admin Password** link and enter the new administrator password in the field below (see [figure 36](#) on page 40).
3. Click in the **Confirm Admin Password** field and enter the password from the **Change Admin Password** field.
4. To assign a user password, repeat steps 2 and 3 in the **User** panel.



**Figure 35. Roles and Permissions Panel**

- When finished, click **SAVE** to set the passwords. To close the window without saving a password, click **CANCEL** or the **X** in the upper-right corner.

**NOTE:** Passwords can be changed but they cannot be removed entirely. The FOX3 must have passwords at all times. These fields cannot be blank.

Role and Permission Settings

ADMIN

Admin Password

.....

Confirm Admin Password

SAVE

USER

User Password

.....

Confirm User Password

CANCEL

Show Passwords

**Figure 36. Passwords Dialog Box**

## LinkLicense Panel

The LinkLicense panel (see [figure 29](#), [6](#) on page 36) displays information about any LinkLicense applied to the FOX3 device (A LinkLicense can be uploaded using the Extron Toolbelt software. See [Software/Firmware Installation](#) on page 26 to download the software).

LinkLicense

i

**No LinkLicense information**

There are currently no LinkLicenses added.

**Figure 37. LinkLicense Panel**

## About the FOX3 T 201

Click on the **ABOUT** link (see [figure 29](#), [7](#) on page 36) to open the **About** dialog box to view general information about the FOX3 T 201, such as the firmware version, copyright, part number, licenses, patents and web page version. Click on the **View the End User License Agreement** link to view the user license.

**About**

About FOX3T 201 MM

Version 1.00.0001-b008

Copyright © 2020 Extron Electronics. All Rights Reserved.

This application is protected by copyright law and international treaties. Unauthorized duplication or distribution is strictly prohibited and will be prosecuted to the maximum extent possible by law.

[View the End User License Agreement](#)

Part #: 60-1600-13

Licenses ^

A B C D E F G H I J K L M N O P Q R S T U  
V W X Y Z

Patents ^

[Extron Patents](#)

Version History ^

Web build version: v\_DWP\_VERSION\_STRING

**Figure 38.** About the FOX3 T 201 Dialog Box

# Equipment Mounting

This section provides procedures for mounting the FOX3 T 201 transmitter.

## Mounting the Transmitter

### ATTENTION:

- Installation and service must be performed by authorized personnel only.
- L'installation et l'entretien doivent être effectués uniquement par un technicien qualifié.

The 1-inch high, half rack width transmitter can be placed on a table, mounted in a rack, or mounted under a desk or table. The transmitter can also be mounted on a projector bracket.

### Tabletop Use

Affix the included rubber feet to the bottom of the unit and place it in any convenient location.

### Mounting kits

Mount the unit using any optional compatible mounting kit listed on the Extron website ([www.extron.com](http://www.extron.com)), in accordance with the directions included with the kit. For rack mounting, see UL Rack-Mounting Guidelines below.

### UL Rack-Mounting Guidelines

The following Underwriters Laboratories (UL) requirements pertain to the installation of the unit into a rack.

- **Elevated operating ambient temperature** — If installed in a closed or multi-unit rack assembly, the operating ambient temperature of the rack environment may be greater than room ambient. Therefore, consider installing the equipment in an environment compatible with the maximum ambient temperature (TMA = +122 °F, +50 °C) specified by Extron.
- **Reduced air flow** — Installation of the equipment in a rack should be such that the amount of air flow required for safe operation of the equipment is not compromised.
- **Mechanical loading** — Mounting of the equipment in the rack should be such that a hazardous condition is not achieved due to uneven mechanical loading.
- **Circuit overloading** — Consideration should be given to the connection of the equipment to the supply circuit and the effect that overloading of the circuits might have on overcurrent protection and supply wiring. Appropriate consideration of equipment nameplate ratings should be used when addressing this concern.
- **Reliable earthing (grounding)** — Reliable earthing of rack-mounted equipment should be maintained. Particular attention should be given to supply connections other than direct connections to the branch circuit (such as use of power strips).

## Extron Warranty

Extron warrants this product against defects in materials and workmanship for a period of three years from the date of purchase. In the event of malfunction during the warranty period attributable directly to faulty workmanship and/or materials, Extron will, at its option, repair or replace said products or components, to whatever extent it shall deem necessary to restore said product to proper operating condition, provided that it is returned within the warranty period, with proof of purchase and description of malfunction to:

**USA, Canada, South America, and Central America:**

Extron  
1230 South Lewis Street  
Anaheim, CA 92805  
U.S.A.

**Asia:**

Extron Asia Pte Ltd  
135 Joo Seng Road, #04-01  
PM Industrial Bldg.  
Singapore 368363  
Singapore

**Japan:**

Extron Japan  
Kyodo Building, 16 Ichibancho  
Chiyoda-ku, Tokyo 102-0082  
Japan

**Europe:**

Extron Europe  
Hanzeboulevard 10  
3825 PH Amersfoort  
The Netherlands

**China:**

Extron China  
686 Ronghua Road  
Songjiang District  
Shanghai 201611  
China

**Middle East:**

Extron Middle East  
Dubai Airport Free Zone  
F13, PO Box 293666  
United Arab Emirates, Dubai

**Africa:**

Extron South Africa  
3rd Floor, South Tower  
160 Jan Smuts Avenue  
Rosebank 2196, South Africa

This Limited Warranty does not apply if the fault has been caused by misuse, improper handling care, electrical or mechanical abuse, abnormal operating conditions, or if modifications were made to the product that were not authorized by Extron.

**NOTE:** If a product is defective, please call Extron and ask for an Application Engineer to receive an RA (Return Authorization) number. This will begin the repair process.

**USA:** 714.491.1500 or 800.633.9876

**Asia:** 65.6383.4400

**Europe:** 31.33.453.4040 or 800.3987.6673

**Japan:** 81.3.3511.7655

**Africa:** 27.11.447.6162

**Middle East:** 971.4.299.1800

Units must be returned insured, with shipping charges prepaid. If not insured, you assume the risk of loss or damage during shipment. Returned units must include the serial number and a description of the problem, as well as the name of the person to contact in case there are any questions.

Extron makes no further warranties either expressed or implied with respect to the product and its quality, performance, merchantability, or fitness for any particular use. In no event will Extron be liable for direct, indirect, or consequential damages resulting from any defect in this product even if Extron has been advised of such damage.

Please note that laws vary from state to state and country to country, and that some provisions of this warranty may not apply to you.