

NAV Pro AV Over IP

NAV E 501 and NAV E 101

Streaming HDMI Encoders



Safety Instructions

Safety Instructions • English

⚠ WARNING: This symbol, , when used on the product, is intended to alert the user of the presence of uninsulated dangerous voltage within the product's enclosure that may present a risk of electric shock.

ATTENTION: This symbol, , when used on the product, is intended to alert the user of important operating and maintenance (servicing) instructions in the literature provided with the equipment.

For information on safety guidelines, regulatory compliances, EMI/EMF compatibility, accessibility, and related topics, see the Extron Safety and Regulatory Compliance Guide, part number 68-290-01, on the Extron website, www.extron.com.

تعليمات السلامة • العربية

⚠ تحذير: هذا الرمز، , عند استخدامه على المنتج، مخصص لتنبيه المستخدم فيما يتعلق بوجود جهد كهربائي غير معزول على الغلاف الخارجي للمنتج وهو ما قد ينطوي على مخاطر حدوث صدمة كهربائية.

انتبه: هذا الرمز، , عند استخدامه على المنتج، مخصص لتنبيه المستخدم بتعليمات التشغيل والصيانة الهامة (الخدمة) في المواد التي يتم توفيرها مع المعدات.

للحصول على المزيد من المعلومات حول إرشادات السلامة، والتوافق التنظيمية، والتوافق الكهرومغناطيسي/المجال الكهرومغناطيسي، وإمكانية الوصول، والموضوعات ذات الصلة، يرجى مراجعة دليل السلامة والتوافق التنظيمي www.extron.com الخاص بإكسترون، الجزء رقم 01-290-68، على موقع إكسترون،

Sicherheitsanweisungen • Deutsch

WARNUNG: Dieses Symbol , auf dem Produkt soll den Benutzer darauf aufmerksam machen, dass im Inneren des Gehäuses dieses Produktes gefährliche Spannungen herrschen, die nicht isoliert sind und die einen elektrischen Schlag verursachen können.

VORSICHT: Dieses Symbol , auf dem Produkt soll dem Benutzer in der im Lieferumfang enthaltenen Dokumentation besonders wichtige Hinweise zur Bedienung und Wartung (Instandhaltung) geben.

Weitere Informationen über die Sicherheitsrichtlinien, Produkthandhabung, EMI/EMF-Kompatibilität, Zugänglichkeit und verwandte Themen finden Sie in den Extron-Richtlinien für Sicherheit und Handhabung (Artikelnummer 68-290-01) auf der Extron-Website, www.extron.com.

Instrucciones de seguridad • Español

ADVERTENCIA: Este símbolo, , cuando se utiliza en el producto, avisa al usuario de la presencia de voltaje peligroso sin aislar dentro del producto, lo que puede representar un riesgo de descarga eléctrica.

ATENCIÓN: Este símbolo, , cuando se utiliza en el producto, avisa al usuario de la presencia de importantes instrucciones de uso y mantenimiento recogidas en la documentación proporcionada con el equipo.

Para obtener información sobre directrices de seguridad, cumplimiento de normativas, compatibilidad electromagnética, accesibilidad y temas relacionados, consulte la Guía de cumplimiento de normativas y seguridad de Extron, referencia 68-290-01, en el sitio Web de Extron, www.extron.com.

Instructions de sécurité • Français

AVERTISSEMENT : Ce pictogramme, , lorsqu'il est utilisé sur le produit, signale à l'utilisateur la présence à l'intérieur du boîtier du produit d'une tension électrique dangereuse susceptible de provoquer un choc électrique.

ATTENTION : Ce pictogramme, , lorsqu'il est utilisé sur le produit, signale à l'utilisateur des instructions d'utilisation ou de maintenance importantes qui se trouvent dans la documentation fournie avec le matériel.

Pour en savoir plus sur les règles de sécurité, la conformité à la réglementation, la compatibilité EMI/EMF, l'accessibilité, et autres sujets connexes, lisez les informations de sécurité et de conformité Extron, réf. 68-290-01, sur le site Extron, www.extron.com.

Istruzioni di sicurezza • Italiano

AVVERTENZA: Il simbolo, , se usato sul prodotto, serve ad avvertire l'utente della presenza di tensione non isolata pericolosa all'interno del contenitore del prodotto che può costituire un rischio di scosse elettriche.

ATTENZIONE: Il simbolo, , se usato sul prodotto, serve ad avvertire l'utente della presenza di importanti istruzioni di funzionamento e manutenzione nella documentazione fornita con l'apparecchio.

Per informazioni su parametri di sicurezza, conformità alle normative, compatibilità EMI/EMF, accessibilità e argomenti simili, fare riferimento alla Guida alla conformità normativa e di sicurezza di Extron, cod. articolo 68-290-01, sul sito web di Extron, www.extron.com.

Instrukcje bezpieczeństwa • Polska

OSTRZEŻENIE: Ten symbol, , gdy używany na produkcie, ma na celu poinformować użytkownika o obecności izolowanego i niebezpiecznego napięcia wewnątrz obudowy produktu, który może stanowić zagrożenie porażenia prądem elektrycznym.

UWAGI: Ten symbol, , gdy używany na produkcie, jest przeznaczony do ostrzeżenia użytkownika ważne operacyjne oraz instrukcje konserwacji (obsługi) w literaturze, wyposażone w sprzęt.

Informacji na temat wytycznych w sprawie bezpieczeństwa, regulacji wzajemnej zgodności, zgodności EMI/EMF, dostępności i Tematy pokrewne, zobacz Extron bezpieczeństwa i regulacyjnego zgodności przewodnik, część numer 68-290-01, na stronie internetowej Extron, www.extron.com.

Инструкция по технике безопасности • Русский

ПРЕДУПРЕЖДЕНИЕ: Данный символ, , если указан на продукте, предупреждает пользователя о наличии неизолированного опасного напряжения внутри корпуса продукта, которое может привести к поражению электрическим током.

ВНИМАНИЕ: Данный символ, , если указан на продукте, предупреждает пользователя о наличии важных инструкций по эксплуатации и обслуживанию в руководстве, прилагаемом к данному оборудованию.

Для получения информации о правилах техники безопасности, соблюдении нормативных требований, электромагнитной совместимости (ЭМП/ЭДС), возможности доступа и других вопросах см. руководство по безопасности и соблюдению нормативных требований Extron на сайте Extron: www.extron.com, номер по каталогу - 68-290-01.

安全说明 • 简体中文

警告: ⚠️ 产品上的这个标志意在警告用户, 该产品机壳内有暴露的危险电压, 有触电危险。

注意: ⚠️ 产品上的这个标志意在提示用户, 设备随附的用户手册中有重要的操作和维护(维修)说明。

关于我们产品的安全指南、遵循的规范、EMI/EMF 的兼容性、无障碍使用的特性等相关内容,

敬请访问 Extron 网站, www.extron.com

, 参见 Extron 安全规范指南, 产品编号 68-290-01。

安全記事 • 繁體中文

警告: ⚠️ 若產品上使用此符號, 是為了提醒使用者, 產品機殼內存在未隔離的危險電壓, 可能會導致觸電之風險。

注意: ⚠️ 若產品上使用此符號, 是為了提醒使用者, 設備隨附的用戶手冊中有重要的操作和維護(維修)說明。

有關安全性指導方針、法規遵守、EMI/EMF 相容性、存取範圍和相關主題的詳細資訊, 請瀏覽 Extron 網站 www.extron.com 然後參閱《Extron 安全性與法規遵守手冊》, 準則編號 68-290-01。

安全上のご注意 • 日本語

警告: この記号 ⚠️ が製品上に表示されている場合は、筐体内に絶縁されていない高電圧が流れ、感電の危険があることを示しています。

注意: この記号 ⚠️ が製品上に表示されている場合は、本機の取扱説明書に記載されている重要な操作と保守(整備)の指示についてユーザーの注意を喚起するものです。

安全上のご注意、法規遵守、EMI/EMF適合性、その他の関連項目については、エクストロンのウェブサイト www.extron.com より「Extron Safety and Regulatory Compliance Guide」(P/N 68-290-01) をご覧ください。

안전 지침 • 한국어

경고: 이 기호 ⚠️가 제품에 사용될 경우, 제품의 인클로저 내에 있는 접지되지 않은 위험한 전류로 인해 사용자가 감전될 위험이 있음을 경고합니다.

주의: 이 기호 ⚠️가 제품에 사용될 경우, 장비와 함께 제공된 책자에 나와 있는 주요 운영 및 유지보수(정비) 지침을 경고합니다.

안전 가이드라인, 규제 준수, EMI/EMF 호환성, 접근성, 그리고 관련 항목에 대한 자세한 내용은 Extron 웹 사이트(www.extron.com)의 Extron 안전 및 규제 준수 안내서, 68-290-01 조항을 참조하십시오.

Copyright

© 2021 Extron. All rights reserved. www.extron.com

Trademarks

All trademarks mentioned in this guide are the properties of their respective owners.

The following registered trademarks (®), registered service marks (SM), and trademarks (TM) are the property of RGB Systems, Inc. or Extron (see the current list of trademarks on the [Terms of Use](#) page at www.extron.com):

Registered Trademarks (®)
Extron, Cable Cubby, ControlScript, CrossPoint, DTP, eBUS, EDID Manager, EDID Minder, eLink, Flat Field, FlexOS, Glitch Free, Global Configurator, Global Scriptor, GlobalViewer, Hideaway, HyperLane, IP Intercom, IP Link, Key Minder, LinkLicense, LockIt, MediaLink, MediaPort, NAV, NetPA, PlenumVault, PoleVault, PowerCage, PURE3, Quantum, Sharelink, Show Me, SoundField, SpeedMount, SpeedSwitch, StudioStation, System <i>INTEGRATOR</i> , TeamWork, TouchLink, V-Lock, VN-Matrix, VoiceLift, WallVault, WindoWall, XPA, XTP, XTP Systems, and ZipClip
Registered Service Mark (SM): S3 Service Support Solutions
Trademarks (TM)
AAP, AFL (Accu-RATE Frame Lock), ADSP (Advanced Digital Sync Processing), AVEdge, CableCover, CDRS (Class D Ripple Suppression), Codec Connect, DDS (Digital Display Sync Processing), DMI (Dynamic Motion Interpolation), Driver Configurator, DSP Configurator, DSVP (Digital Sync Validation Processing), EQIP, Everlast, FastBite, Flex55, FOX, FOXBOX, IP Intercom HelpDesk, MAAP, MicroDigital, Opti-Torque, PendantConnect, ProDSP, QS-FPC (QuickSwitch Front Panel Controller), Room Agent, Scope-Trigger, SIS, Simple Instruction Set, Skew-Free, SpeedNav, Triple-Action Switching, True4K, Vector™ 4K, WebShare, XTRA, and ZipCaddy

FCC Class A Notice

This equipment has been tested and found to comply with the limits for a Class A digital device, pursuant to part 15 of the FCC rules. The Class A limits provide reasonable protection against harmful interference when the equipment is operated in a commercial environment. This equipment generates, uses, and can radiate radio frequency energy and, if not installed and used in accordance with the instruction manual, may cause harmful interference to radio communications. Operation of this equipment in a residential area is likely to cause interference. This interference must be corrected at the expense of the user.

ATTENTION:

- The Twisted Pair Extension technology works with unshielded twisted pair (UTP) or shielded twisted pair (STP) cables; **but to ensure FCC Class A and CE compliance, STP cables and STP Connectors are required.**
- La technologie extension paires torsadées fonctionne avec les câbles paires torsadées blindées (UTP) ou non blindées (STP). Afin de s'assurer de la compatibilité entre FCC Classe A et CE, les câbles STP et les connecteurs STP sont nécessaires.

NOTES:

- This unit was tested with shielded I/O cables on the peripheral devices. Shielded cables must be used to ensure compliance with FCC emissions limits.
- For more information on safety guidelines, regulatory compliances, EMI/EMF compatibility, accessibility, and related topics, see the [Extron Safety and Regulatory Compliance Guide](#) on the Extron website.

Battery

CAUTION: Risk of explosion — Do not replace the battery with an incorrect type. Dispose of used batteries according to the instructions.

ATTENTION : Risque d'explosion — Ne pas remplacer la pile par le mauvais type de pile. Débarrassez-vous des piles usagées selon le mode d'emploi.

ATTENTION:

- If not provided with a power supply, this product is intended to be supplied by a UL Listed power source marked "Class 2" or "LPS" and rated output 12Vdc, minimum 2.0 A or 56Vdc (PoE), minimum 0.8 A.
- Si le produit n'est pas fourni avec une source d'alimentation, il doit être alimenté par une source d'alimentation certifiée UL de classe 2 ou LPS, avec une tension nominale 12 Vcc, 2.0 A minimum ou 56Vdc (PoE), minimum 0.8 A.

Conventions Used in this Guide

Notifications

The following notifications are used in this guide:

CAUTION: Risk of minor personal injury.

ATTENTION : Risque de blessure mineure.

ATTENTION:

- Risk of property damage.
- Risque de dommages matériels.

NOTE: A note draws attention to important information.

TIP: A tip provides a suggestion to make working with the application easier.

Software Commands

Commands are written in the fonts shown here:

```
^AR Merge Scene, ,0p1 scene 1,1 ^B 51 ^W ^C.0  
[01] R 0004 00300 00400 00800 00600 [02] 35 [17] [03]  
Esc X1 * X19 * X23 * X26 * X25 CE ←
```

NOTE: For commands and examples of computer or device responses used in this guide, the character “0” is the number zero and “O” is the capital letter “o.”

Computer responses and directory paths that do not have variables are written in the font shown here:

```
Reply from 208.132.180.48: bytes=32 times=2ms TTL=32  
C:\Program Files\Extron
```

Variables are written in slanted form as shown here:

```
ping xxx.xxx.xxx.xxx -t  
SOH R Data STX Command ETB ETX
```

Selectable items, such as menu names, menu options, buttons, tabs, and field names are written in the font shown here:

```
From the File menu, select New.  
Click the OK button.
```

Specifications Availability

Product specifications are available on the Extron website, www.extron.com.

Extron Glossary of Terms

A glossary of terms is available at <http://www.extron.com/technology/glossary.aspx>.

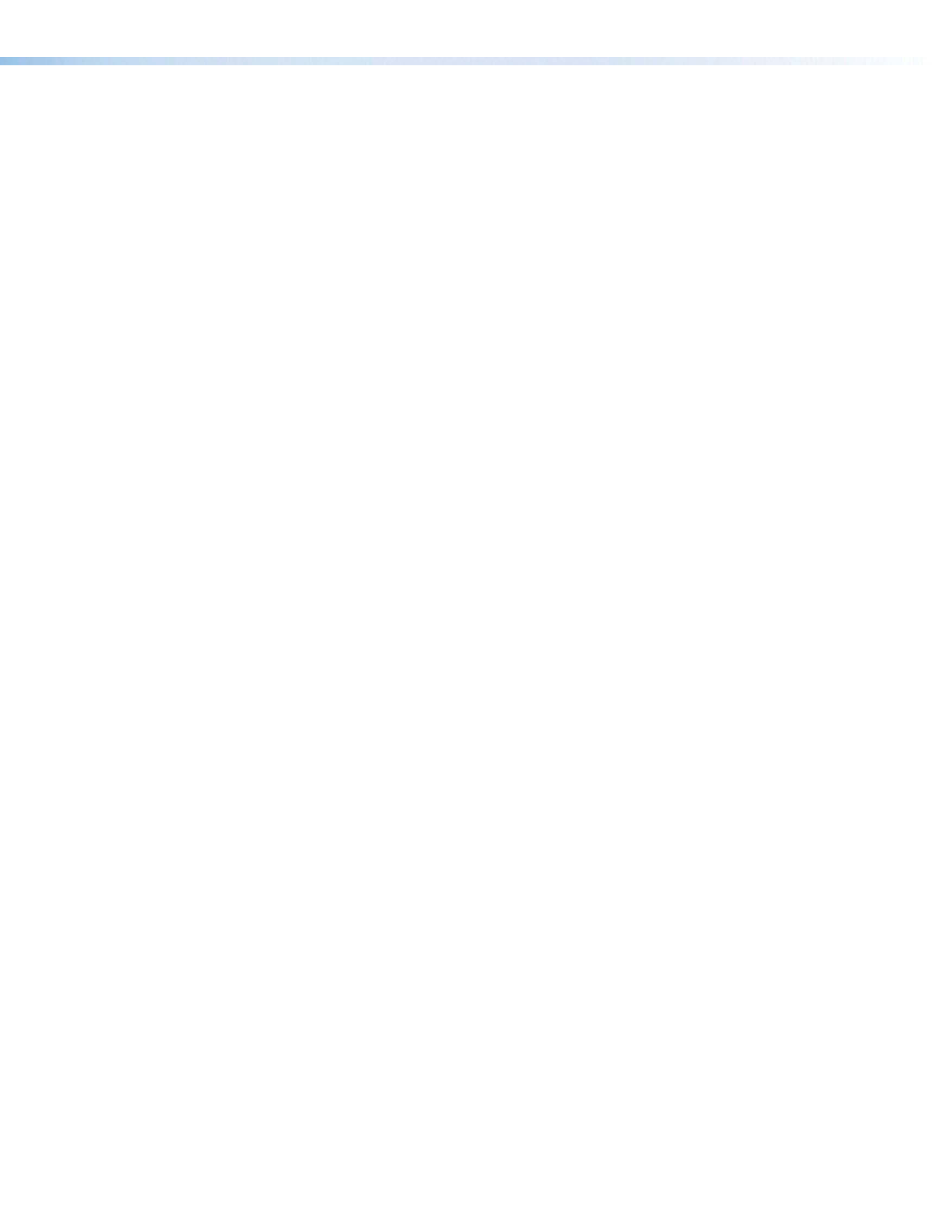

Contents

Introduction	1
About this Guide.....	1
About the NAV System.....	1
About the Encoder	1
About the Decoder	2
System Interaction and Capabilities	2
Features	3

Installation and Basic Operation	5
Mounting.....	5
Rear Panel Connections and Features.....	5
Connector and Cable Details	7
Front Panel Features.....	11
Startup and Basic Operation	13
Power.....	13
Pairing Devices Manually	13
Operation	14

HTML Operation	16
Opening the Embedded HTML Pages	16
Using the HTML Pages.....	19
Input Configuration Page	20
Output Configuration Page	23
Ties Page	31
Tools Pages.....	32
Monitoring Page	40
Settings Page	45
About Page	56

Control System.....	57
Secure Platform Device	57
Toolbelt.....	57
Global Configurator Plus and Professional	59
Global Scriptor.....	60

SIS Operation	61
Host-to-Encoder Communications	61
Encoder-Initiated Messages.....	61
Encoder Error Responses.....	62
Using the Command and Response Tables	62
Common symbol definitions.....	62
SIS Command and Response Tables.....	63

Troubleshooting	67
Alarms.....	67

Reference Information	70
Mounting the Encoder	70
Tabletop Use	70
Mounting kits.....	70
UL Rack-Mounting Guidelines	71

Introduction

This section contains the following topics:

- [About this Guide](#)
- [About the NAV System](#)
- [Features](#)

About this Guide

This guide contains installation, configuration, and operating information for the following Extron streaming encoders:

- **NAV E 501 Encoder** — Streams HDMI video and audio over a managed 1G IP network. Also supports USB and Ethernet extension.
- **NAV E 101 Encoder** — Streams HDMI video and audio over a managed 1G IP network.

NOTE: In this guide:

- The NAV E 501 and NAV E 101 are both referred to as an “encoder.” They are referenced by model name when differences exist.
- NAV encoders and decoders collectively are referred to as “endpoints.”

About the NAV System

The Extron NAV decoders and one or more compatible encoders form an AV distribution and switching matrix on an Internet Group Management Protocol (IGMP) Managed IP Network. The encoders are configured for low latency multicast streaming. The decoders are configured to join the assigned multicast group.

About the Encoder

A NAV encoder inputs an HDMI video signal and generates a video and audio stream that can be transmitted over an IP network using the Extron PURE3 Codec. The PURE3 Codec exceeds many of the performance characteristics of existing compression formats and provides exceptionally robust protection against network errors, making it ideal for quality-critical applications.

The data stream can include:

- HDCP-compliant HDMI video (which can include embedded digital audio [SMPTE 299M and SMPTE 272M-A]) at resolutions up to 4k @ 60 Hz
- Optional analog audio
- RS-232 and IR control signals
- **NAV E 501 only** — USB 2.0 port control and data signals
- **NAV E 501 only** — An Ethernet Extension port allows communication to the same network

You can manage the endpoints using an Extron NAVigator System Manager (see figure 1). The base version of the NAVigator can control up to 16 endpoints. Available LinkLicense expansion options can accommodate up to 240 endpoints.

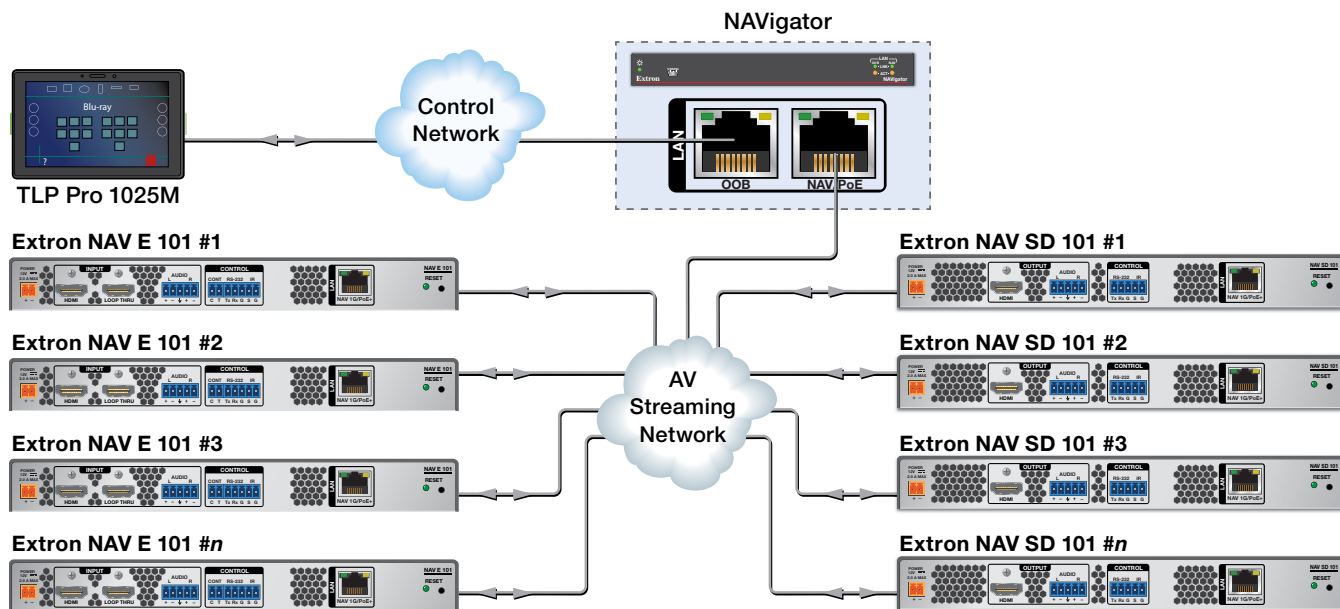

Figure 1. Typical NAV Application

The streamed NAV signal is routed using a managed network switch and can be dedicated to a specific VLAN. AV switching can be done via a control system by interfacing to the NAV decoder or the NAVigator.

NOTE: The RS-232 and IR communications are driven via a control system. The encoder and decoder do not generate or respond to the RS-232 and IR communication signals.

About the Decoder

One or more compatible decoders, such as the NAV SD 501 or NAV SD 101, decode the data stream back into the original video and audio signal formats and output them locally.

System Interaction and Capabilities

Each encoder and decoder has an integrated web interface. All normal system configuration and control is via the web interface of the NAVigator. Using a computer on the same network and a standard web browser; such as Google Chrome™, Mozilla™ Firefox™, or Microsoft® Edge™; you can configure any encoder or decoder unit in the system.

The embedded audio can be transported as a 2-channel LPCM uncompressed stream. Audio can follow video to the same decoder or be broken away to a different endpoint.

A dedicated RS-232/IR port, a secure platform device (SPD), is available for distributing RS-232 and IR data with the coded/decoded video, such as for control of a projector. Tally and Contact Closure supports Extron Show Me Cables.

The units are housed in 1-inch high, half-rack width metal enclosures that can be mounted in any standard 19-inch rack or under furniture with optional mounting kits.

The external 100 VAC to 240 VAC, 50-60 Hz power supply provides worldwide power compatibility.

Features

- **Encodes and streams video and audio over 1 Gbps Ethernet networks** — Standard 1 Gbps Ethernet supports flexible system design and transmission over large distances to any location.
- **Supports HDMI 2.0 at resolutions up to 4K/60 @ 4:4:4** — HDMI up to 4K @ 60 Hz (4096 x 2160) with full 4:4:4 chroma subsampling ensures accurate reproduction of source images.
- **PURE3 Codec** — Patented by Extron, the wavelet-based compression technology delivers high image quality with very low-latency at highly efficient bit rates. With its high immunity to network errors and built-in error concealment, PURE3 facilitates reliable, real-time delivery of visually lossless video over IP networks.
- **PURE3 Intelligent Selective Streaming (ISS)** — Leverages low motion content to achieve extremely low bitrates while maintaining visually lossless performance.
- **Interoperable with 10 Gbps NAV endpoints** — 1 Gbps video can be readily decoded by 10 Gbps decoders for greater compatibility in mixed 1 Gbps/10 Gbps solutions.
- **Ultra-low latency with high quality video** — Streams professional-grade video with ultra-low latency using the unique wavelet-based Extron PURE3® codec, guaranteeing exceptional user experience and accurate reproduction of every detail.
- **AES67 audio support** — Supports the AES67 audio over IP standard, providing compatibility with Extron and third-party DSP processors.
- **HDCP 2.3 compliant** — Ensures display of content-protected media and interoperability with other HDCP-compliant devices.
- **(NAV E 501 only) USB 2.0 extension** — Built-in USB 2.0 extension facilitates connection to peripheral USB devices over the same cable as video and audio. Ideal for KVM applications or remote connectivity for USB cameras or storage devices.
- **(NAV E 501 only) Ethernet expansion** — Built-in Ethernet expansion facilitates connection to peripheral Ethernet-enabled devices over the same cable as video and audio. Saves on cabling cost in installations with any remote devices requiring LAN connectivity.
- **PoE+ compatibility eliminates the need for a local power supply** — PoE+ enables receipt of power directly from the PoE switch, eliminating the need for bulky local power supplies.
- **SRTP stream encryption (SRTP)** — Ensures encryption, message authentication, and data integrity for video and data streams.
- **Audio breakaway enables independent audio and video switching** — Provides the capability to break away an audio signal from its corresponding video signal.
- **Customizable Screen Saver** — Displays a user-supplied custom image, black screen, blue screen, or the last video frame when no active video signal or stream is present.
- **Priority Routing** — Assign custom tags to endpoints using built-in NAVigator HTML pages. Tags can be used to further classify endpoints, easily locate them on the network, or apply rules for routing with an Extron control system.
- **802.1X port-based Network Access Control** — Supports 802.1X port-based authentication, requiring that all devices are approved before network access is granted.
- **Certified FIPS 140-2 module** — Extron cryptographic module meets NIST and CCS guidelines and is certified by CMVP to the FIPS 140-2 information processing standard in order to ensure protection of sensitive data.
- **Active Directory support** — Integrates with Microsoft® Active Directory, simplifying user management, group authentication, and helping to maintain strong security policies.

- **Adjustable bit rate** — Selects bit rates while maintaining image quality for a more flexible network configuration that easily adapts to different application requirements. A non-blocking solution is available to accommodate even very large installations.
- **Error concealment** — Offers high immunity to network errors, ensuring reliable transmission of high quality imagery with the ability to conceal errors even during incidents of heavy packet loss.
- **HDMI loop-through** — Local HDMI output provides signal for a local display, an AV system, or a hardware codec, enabling monitoring or sharing of content without the need for a separate distribution amplifier.
- **Embedded web interface** — Intuitive, user-friendly embedded web interface simplifies device configuration, setup, and system operation.
- **EDID Minder automatically manages EDID communication between connected devices** — EDID Minder ensures that all sources power up properly and reliably output content for display.
- **Key Minder continuously verifies HDCP compliance for quick, reliable switching** — Key Minder authenticates and maintains continuous HDCP encryption between input and output devices to ensure quick and reliable switching in professional AV environments, while enabling simultaneous distribution of a single source signal to one or more displays.
- **HDCP Visual Confirmation** — When HDCP-encrypted content is transmitted to a non-HDCP compliant display, a full-screen green signal is sent to the display for immediate visual confirmation that protected content cannot be viewed on that display.
- **Supports analog and embedded HDMI audio signals** — Directly interfaces with common AV source signals for compatibility with most audio devices.
- **Compatible with Show Me cables** — Show Me cables and retractors provide convenient connectivity, user input selection, and control of AV systems.
- **Integrates with Pro Series control systems for secure, user-friendly external control** — Designed to integrate directly with Extron Pro Series control systems for secure, encrypted RS-232 and IR control of external devices without the need for additional control processors.
- **Consumer Electronics Control (CEC) capability** — CEC commands can be triggered to control displays or other AV devices connected over HDMI.
- **Secure Platform Interface** — Working natively with NAV Systems, Extron Pro Series control systems offer flexible system management and matrix switching control via a Secure Platform Interface that encrypts all commands from control processor to endpoint. Together, NAV and Extron Pro Series control systems create the most secure and reliable Pro AV over IP solution on the market.
- **Multicast filtering with IGMPv3** — Supports multicast filtering with IGMPv3 for lower bandwidth consumption. Enables use of standard network equipment.
- **One-button endpoint identification** — Identify endpoints with an ID button and indicator for quick discovery of units on a network, simplifying diagnostics and installation.
- **External Extron Everlast power supply included** — Provides worldwide power compatibility with high-demonstrated reliability and low power consumption.
- **Extron Everlast Power Supply is covered by a 7-year parts and labor warranty.**
- **1-inch (2.5 cm) high, half rack width metal enclosure** — Compact, low profile enclosure for discreet placement and concealment.
- **ZipClip 400 included** — Enables quick and secure mounting to rack rails, tables, shelves, and lecterns.

Installation and Basic Operation

This section describes the installation and the operation of the NAV E 501 and NAV E 101 encoders, including:

- [Mounting](#)
- [Rear Panel Connections and Features](#)
- [Front Panel Connection and Indicators](#)
- [Startup and Basic Operation](#)

Mounting

If desired, mount the encoder in a rack (see [Mounting the Encoder](#) on page 70).

Rear Panel Connections and Features

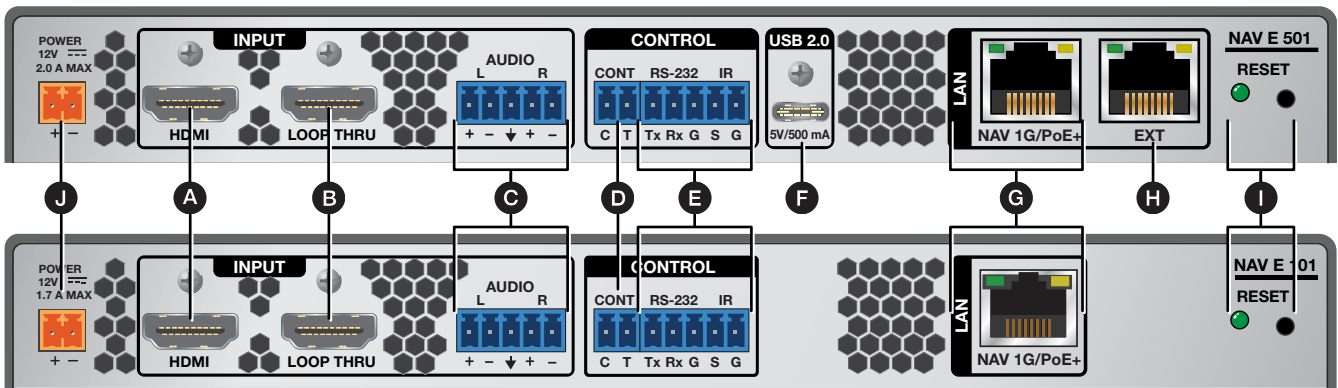
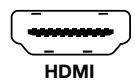

Figure 2. NAV E 501 and NAV E 101 Rear Panel Connectors and Features

- | | |
|-------------------------------|--|
| A HDMI input port | F USB 2.0 port (NAV E 501 only) |
| B Loop Thru port | G NAV 1G/PoE+ port |
| C Audio input port | H Extension port (NAV E 501 only) |
| D Contact Closure port | I Reset button and LED |
| E Control port | J Power connector |

A **HDMI input port** — Connect an HDMI cable between this port and the HDMI output port (or DVI port, with an appropriate adapter) of the digital video source. See [LockIt Lacing Brackets](#) on page 7 to use the LockIt HDMI Cable Lacing Bracket to secure the connector to the encoder.



B **Loop Thru port** — Connect a display to this female HDMI connector for local loop-through monitoring of the source signal. See [LockIt Lacing Brackets](#).



- C Audio input port** (see [page 5](#)) — Connect balanced or unbalanced stereo audio input to this 5-pole, 3.5 mm captive screw connector (see [Analog audio connectors](#) on page 8 to wire the connector).

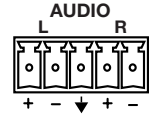

- D Control Contact Closure port** — Connect an Extron Show Me cable to the port to allow an Extron Teamwork 400 user to request to take over the presentation from this encoder (see the *Teamwork 400 User Guide*, available at www.extron.com).



- E Control RS-232/IR port** — Connect a serial RS-232 signal, a modulated IR signal, or both to this 3.5 mm, 5-pole captive screw connector for bidirectional RS-232 and IR communication (see [Control connector wiring](#) on page 8 to wire the connector).

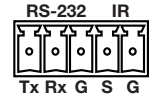

- F USB 2.0 port** (NAV E 501 only) — Connect a USB Type-C® cable from a USB host or a USB device. See [LockIt Lacing Brackets](#) on page 7 to securely fasten the USB connector to the encoder.



NOTE: This connector is limited to supplying 500 mA in USB device mode.

- G NAV 1G/PoE+ port** — Connect to an Ethernet LAN on which one or more decoders also reside for streaming, control, and PoE+.

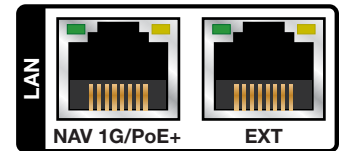

- H Extension port** (NAV E 501 only) — If desired, connect another networked device to this port. The port acts as a networked switch to the NAV 1G/PoE+ port (**G**).

NOTES:

- See [TP cable termination](#) on page 9 to properly wire the RJ-45 connectors **G** and **H**.
- The Extension port (**H**) cannot provide PoE.
- RJ-45 port LEDs for both ports indicate as follows:
 - **Act (amber) LED** — Indicates transmission of data packets on the RJ-45 connector. This LED blinks as the encoder communicates.
 - **Link (green) LED** — Indicates that the encoder is properly connected to an Ethernet LAN. This LED lights steadily.

- I Reset button and LED** — The Reset button initiates three levels of encoder reset. For the different reset levels, press and hold the button while the encoder is running or while you power up the encoder (see [Reset Operations](#) on page 14 for details).



- J Power connector** — Plug the included external 12 VDC power supply into this 2-pole connector to power the encoder locally.

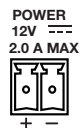

NOTE: Alternatively, the encoder can be powered via PoE.

ATTENTION:

- Do not connect power to the encoder until you have read the **CAUTION** and **ATTENTION** notices on page 10.
- Ne connectez pas l'alimentation à l'encodeur avant d'avoir lu les rubriques « **ATTENTION** » des page 10.

Connector and Cable Details

HDMI connectors

HDMI signals for 4K video run at a very high frequency and are especially prone to errors caused by bad video connections, too many adapters, or excessive cable length. To avoid the loss of an image or jitter, follow these guidelines:

- Do not exceed 12 feet (3.6 meters) on the encoder input or loop-thru output.
- Use only a cable designed for HDMI signals.
- Limit or avoid the use of adapters.
- Use only cables specifically intended for HDMI or DVI signals. Use of non-HDMI or non-DVI cables or modified cables can result in a missing video output.

LockIt Lacing Brackets

To securely fasten an HDMI or USB cable to a device:

1. Plug the rear panel HDMI or USB (NAV E 501 only) cable into the panel connection (see figure 3, ①).

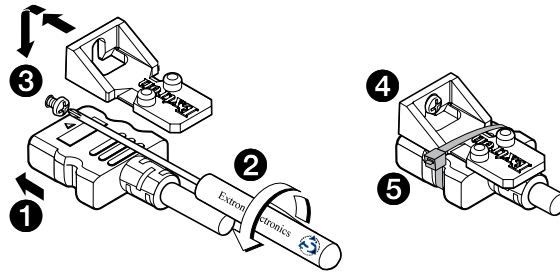

Figure 3. Installing the LockIt Lacing Bracket

2. Loosen the HDMI connection mounting screw from the panel enough to allow the LockIt lacing bracket to be placed over it (②). The screw does not have to be removed.
3. Place the LockIt lacing bracket on the screw and against the HDMI connector, then tighten the screw to secure the bracket (③).

ATTENTION:

- Do not overtighten the HDMI connector mounting screw. The shield to which it fastens is very thin and can easily be stripped.
 - Ne serrez pas trop la vis de montage du connecteur HDMI. Le blindage auquel elle est attachée est très fin et peut facilement être dénudé.
4. Loosely place the included tie wrap around the HDMI connector and the LockIt lacing bracket as shown (④).
 5. While holding the connector securely against the lacing bracket, use pliers or similar tools to tighten the tie wrap, then remove any excess length (⑤).

Analog audio connectors

See figure 4 to wire a connector for the appropriate input type. Connectors are included with the encoder, but you must supply the audio cable. Use the supplied tie-wrap to strap the cable to the extended tail of the connector.

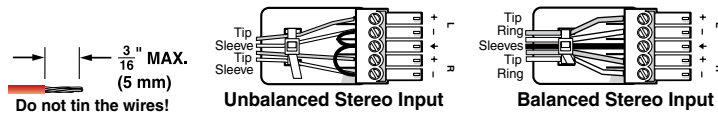
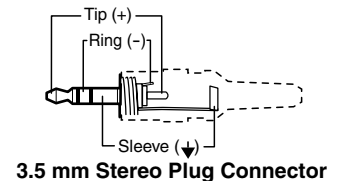

Figure 4. Captive Screw Connector Wiring for Audio Inputs

NOTES:

- The length of exposed wires is important. The ideal length is 3/16 inch (5 mm).
- If the stripped section of wire is longer than 3/16 inch, the exposed wires may touch, causing a short circuit.
- If the stripped section of wire is shorter than 3/16 inch, wires can be easily pulled out even if tightly fastened by the captive screws.
- Do not tin the power supply leads before installing them in the connector. Tinned wires are not as secure in the connector and could be pulled out.

A balanced stereo audio connector consists of a tip, ring, and sleeve. An unbalanced mono audio connector consists of a tip and sleeve. When you are making connections for the units from existing audio cables, see the drawing at right to identify the tip, ring, and sleeve parts of the connector. The ring, tip, and sleeve wires are also shown on the captive screw audio connector diagram (see figure 4).



3.5 mm Stereo Plug Connector

Control connector wiring

Figure 5 shows how to wire the Control RS-232/IR connector.

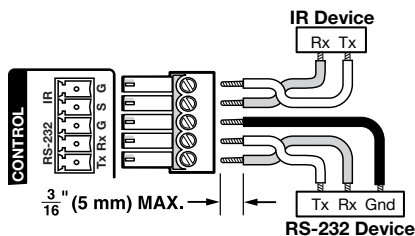

Figure 5. Control Connector Wiring

NOTES:

- The IR S and G line pair and the RS-232 Tx and Rx line pair must each cross once between this connector and the source or destination.
- The length and preparation of exposed wires is important (see the audio connector **NOTES** above for details).

TP cable termination

The encoder NAV 1G/PoE+ port supports 1000Mbps (1000base T — Gigabit Ethernet), half-duplex and full-duplex Ethernet connections. It is vital that your Ethernet cable be the correct cable type and that it be properly terminated with the correct pinout. Ethernet links use Category (CAT) 5e or CAT 6, unshielded twisted pair (UTP) or shielded twisted pair (STP) cables, terminated with RJ-45 connectors. Ethernet cables are limited to a length of 328 feet (100 meters).

NOTES:

- A CAT 5e cabling infrastructure is the minimum acceptable to support a NAV system. Anything less is insufficient.
- Do not stretch or bend cables. Transmission errors can occur.

The Ethernet cable must be terminated as a patch (straight-through) cable and must be properly terminated in accordance with the **TIA/EIA T568-B** wiring standard (see figure 6).

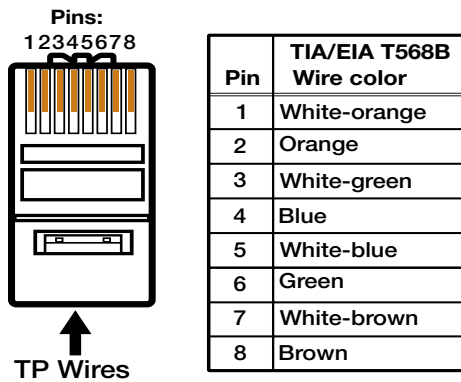

Figure 6. RJ-45 Connector and Pinout Table

Power supply wiring

Figure 7 shows how to wire the connector. Use the supplied tie-wrap to strap the power cord to the extended tail of the connector.

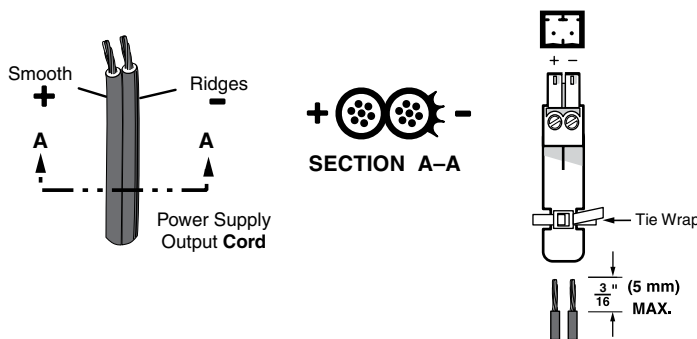

Figure 7. Power Connector Wiring

CAUTION:**ATTENTION :**

- The DC output cables must be kept separate from each other while the power supply is plugged in. Remove power before wiring.
- Les câbles de sortie CC doivent être séparés les uns des autres tant que la source d'alimentation est branchée. Coupez l'alimentation avant d'effectuer les raccordements.
- The length of exposed wires is critical. The ideal length is 3/16 inch (5 mm).
 - Any longer and the exposed wires may touch, causing a short circuit.
 - Any shorter and the wires can be easily pulled out even if tightly fastened by the captive screws.
- La longueur des câbles exposés est primordiale. La longueur idéale est de 5 mm (3/16 inches).
 - S'ils sont un peu plus longs, les câbles exposés pourraient se toucher et provoquer un court circuit.
 - S'ils sont un peu plus courts, ils pourraient sortir, même s'ils sont attachés par les vis captives.
- Do not tin the power supply leads before installing them in the connector. Tinned wires are not as secure in the connector and could be pulled out.
- Ne pas étamer les conducteurs avant de les insérer dans le connecteur. Les câbles étamés ne sont pas aussi bien fixés dans le connecteur et pourraient être retirés.

ATTENTION:

- This product is intended to be supplied by a UL Listed power source marked "Class 2" or "LPS," rated 12 VDC, 2.0 A minimum. Always use a power supply supplied by or specified by Extron. Use of an unauthorized power supply voids all regulatory compliance certification and may cause damage to the supply and the end product.
- Ce produit est destiné à une utilisation avec une source d'alimentation listée UL avec l'appellation « Classe 2 » ou « LPS » et normée 12 Vcc, 2,0 A minimum. Utilisez toujours une source d'alimentation fournie ou recommandée par Extron. L'utilisation d'une source d'alimentation non autorisée annule toute conformité réglementaire et peut endommager la source d'alimentation ainsi que le produit final.
- Unless otherwise stated, the AC/DC adapters are not suitable for use in air handling spaces or in wall cavities.
- Sauf mention contraire, les adaptateurs AC/DC ne sont pas appropriés pour une utilisation dans les espaces d'aération ou dans les cavités murales.
- The installation must always be in accordance with the applicable provisions of National Electrical Code ANSI/NFPA 70, article 725 and the Canadian Electrical Code part 1, section 16. The power supply shall not be permanently fixed to a building structure or similar structure.
- Cette installation doit toujours être en accord avec les mesures qui s'applique au National Electrical Code ANSI/NFPA 70, article 725, et au Canadian Electrical Code, partie 1, section 16. La source d'alimentation ne devra pas être fixée de façon permanente à une structure de bâtiment ou à une structure similaire.

ATTENTION:

- Power supply voltage polarity is critical. Incorrect voltage polarity can damage the power supply and the unit. The ridges on the side of the cord (see [figure 7](#) on page 9) identify the power cord negative lead.
- La polarité de la source d'alimentation est primordiale. Une polarité incorrecte pourrait endommager la source d'alimentation et l'unité. Les stries sur le côté du cordon (voir [l'illustration 7](#) sur la page 9) permettent de repérer le pôle négatif du cordon d'alimentation.

To verify the polarity before connection, plug in the power supply with no load and check the output with a voltmeter.

Front Panel Features

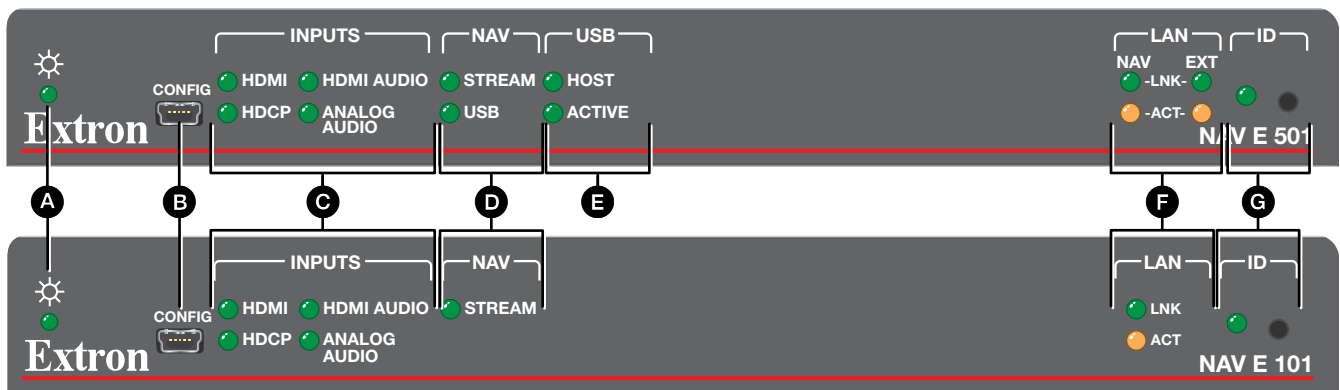

Figure 8. Encoder Front Panel Features

- | | |
|-----------------------------|------------------------------------|
| A Power LED | E USB LEDs (NAV E 501 only) |
| B Configuration port | F LAN LEDs |
| C Inputs LEDs | G ID button and LED |
| D NAV LEDs | |

A Power LED — Indicates power and startup status, as follows:

- **Blinking** — The unit is receiving power, either locally or via PoE and is booting up.
- **Lit** — The unit is receiving power, either locally or remotely (via PoE) and is operational.

B Configuration port — This USB mini-B port (USB 2.0) can be used to configure the encoder and to update firmware.

C INPUTS LEDs — Indicate status of the signal inputs, as follows:

- **HDMI LED** — The encoder is receiving an active HDMI input signal.
- **HDCP LED** — The HDMI signal is HDCP encrypted.
- **HDMI Audio LED** — The embedded HDMI audio input is selected.
- **Analog Audio LED** — The analog audio input is selected.

- ⓓ **NAV LEDs** (see [figure 8](#) on page 11) — Indicate the output status of the AV and USB (NAV E 501 only) streams, as follows:

Stream LED

- **Lit steadily** — The encoder is actively streaming a NAV output consisting of video, audio, or both to one or more NAV decoders.
- **Blinking** — The encoder is actively streaming a NAV output, but network errors are present.
- **Unlit** — The encoder is not actively streaming a NAV output.

USB (NAV E 501 only)

- **Lit steadily** — The encoder is actively sending and receiving a NAV USB stream.
- **Blinking** — The encoder is unable to establish a NAV USB stream.
- **Unlit** — The encoder is not actively sending and receiving a NAV USB stream.

- ⓔ **USB LEDs** (NAV E 501 only) — Indicates the status of the USB mode, as follows:

Host

- **Lit steadily** — The encoder is in USB host mode, the default condition.
- **Unlit** — The encoder is in USB device mode.

NOTES:

- You can tie a USB host only to a USB device for proper system operation.
- If you connect a host, such as a PC, to an endpoint that is in USB device mode, the endpoint cannot recognize the device.

Active

- **Lit steadily** — A host or USB device is connected to the rear panel USB port.
- **Unlit** — No host or USB device is connected to the rear panel USB port.
- **Blinking** — A USB device or hub is connected to the encoder and is drawing more power than the USB port can supply.

- ⓕ **LAN LEDs** — Indicate the status of the network connections, as follows:

NAV LEDs (NAV E 501) or **LAN LED** (NAV E 101) — Indicates the NAV network connection status.

Link LED — Indicates the status of the link.

- **Lit steadily** — Indicates that a network link is established at 1 Gbps.
- **Blinking** — Indicates that network link is established less than 1 Gbps.

Act LED — Indicates the network traffic rate. The blink rate corresponds to activity.

Ext LEDs (NAV E 501 only) — Indicates the Ethernet Extension status.

Link LED — Indicates the status of the link.

- **Lit steadily** — Indicates that a network link is established.
- **Blinking** — Indicates that network link is established less than 1 Gbps.

Act LED — Indicates the network traffic rate. The blink rate corresponds to activity.

- ⓖ **ID button and LED** — The recessed ID button, when pressed, identifies the encoder to other network units and to the embedded HTML pages (see [Pairing Devices Manually](#) on page 13). The LED blinks when the encoder is in pairing mode and lights when it is paired or device identification is selected from the encoder or NAVigator HTML page.

NOTE: The ID button triggers the **Status** on-screen display (OSD), which shows on the Loop Thru port (see [item B](#) on page 5).

Startup and Basic Operation

Power

The encoder can be powered in one of three ways:

- Locally, from the included external power supply and via the power connector (see **J** on page 6).
- Remotely, receiving PoE via the NAV 1G/PoE+ port (see **G**); either from the network switch or from an optional PI 140 Power Injector.
- Locally (**J**) and remotely (**G**), with priority on the NAV 1G/PoE+ port. If PoE voltage drops below a threshold, the encoder immediately transitions to the power connector with no effect on system operation.

When power is applied, the encoder runs a series of self-tests that blink the front panel Power LED and all other indicators. The encoder then boots the NAV operating system. It can take approximately 45 seconds for self-test and system startup to complete. When the process is complete, the Power LED lights steadily.

NOTE: The encoder is NOT operational until the boot process is complete (the Power LED is lit steadily).

Pairing Devices Manually

Manually pair devices as follows:

1. Use a Tweezer or other small screwdriver to press and hold the encoder front panel **ID** button for approximately 3 seconds, until the ID LED blinks. The encoder enters pairing mode.
2. One at a time, use a Tweezer or other small screwdriver to press and hold the decoder front panel **ID** button for approximately 3 seconds, until the ID LED blinks. Release the **ID** button. The decoder is now paired to the encoder.
3. Repeat step 2 for each decoder.
4. Use a Tweezer or other small screwdriver to press and release the encoder front panel **ID** button. The encoder exits pairing mode.
5. Repeat steps 1 through 4 to pair decoders to other encoders.



NOTE: Units can be paired manually via the ID button, but they cannot be unpaired manually. To unpair units, use the embedded HTML pages of either the decoder (see the applicable decoder user guide) or of the NAVigator (see the *NAVigator User Guide*). The applicable user guides are available at <https://www.extron.com>.

Operation

After the encoder, all decoders, and their connected devices are fully booted up and operational (the Power LED on each unit is lit steadily) and the devices are paired, the system is fully operational. If any problems are encountered, ensure all cables are routed and connected properly.

System operation with a NAVigator

Your NAV system must include an Extron NAVigator, a system manager that configures and controls the AV streaming system. The NAVigator allows you to make changes to multiple endpoints in the system from a central location, simplifying operations such as making ties or bulk configuration.

The base version of the NAVigator can support up to 16 endpoints by default, but if a LinkLicense is installed, support can be expanded to up to 240 endpoints, depending on the LinkLicense.

See the *NAVigator User Guide*, available at <https://www.extron.com> for details.

Configuration and other operations

Configuration and more complex operation of the system is accomplished via embedded web pages (see **HTML Operation**, beginning on page 16) or Extron Toolbelt. Simple Instruction Set (SIS) commands (see **SIS Operations**, starting on page 61) cannot be issued directly to the encoder, but are issued via an Extron control system on the AV network using a process known as “encapsulation” (see the *NAVigator User Guide*, available at <https://www.extron.com> for details).

Reset operations

The rear panel **Reset** button initiates three levels of resets (numbered 1, 4, and 5 for comparison with an Extron IPL product). The **Reset** button is recessed, so use a pointed stylus, ballpoint pen, or small screwdriver to access it.

See the **table** on page 15 for a summary of the modes.

ATTENTION:

- Review the reset modes carefully. Using the wrong reset mode may result in unintended loss of flash memory programming, port reassignment, or an encoder reboot.
- Étudier de près les différents modes de réinitialisation. Appliquer le mauvais mode de réinitialisation peut causer une perte inattendue de la programmation de la mémoire flash, une reconfiguration des ports ou une réinitialisation du contrôleur.

NOTES:

- The reset modes listed in the **table** are separate functions, not a continuation from mode 1 to mode 5.
- The modes listed close all open IP and other connections and close all sockets.

Reset Mode Comparison and Summary			
Mode	Activation	Result	Purpose and Notes
1 Hardware reset	Hold down the recessed Reset button while applying power to the unit. NOTE: After a mode 1 reset is performed, update the unit firmware to the latest version. Do not operate the unit firmware version that results from the mode 1 reset. If you want to use the factory default firmware, you must upload that version again (see Firmware tab on page 36 for details on uploading firmware).	The unit reverts to the factory default firmware. All user files and settings, such as IP settings, are maintained. NOTE: If you do not want to update firmware, or you performed a mode 1 reset by mistake, cycle power to the unit to return to the firmware version that was running before the mode 1 reset (see About Page on page 56 to find the firmware version).	Use to return the unit to the factory default firmware version if incompatibility issues arise with user-loaded firmware.
4 Reset IP (SW) settings	Hold the Reset button for approximately 6 seconds, until the Reset LED blinks twice (once at 3 seconds and again at 6 seconds). Then momentarily press Reset within 1 second.	Resets all the IP settings without affecting the device configuration: <ul style="list-style-type: none"> Enables ARP capability. Sets the IP address, subnet address, gateway address, and port mapping to the factory default. Sets the Multicast IP, stream number and device name to the factory default. Turns DHCP on. The Reset LED blinks three times in succession during the reset.	Enables you to set IP address information using ARP and the MAC address.
5 Factory (SW) reset	Hold the Reset button for approximately 9 seconds, until the Reset LED blinks three times (once at 3 seconds, again at 6 seconds, and then again at 9 seconds). Then momentarily press Reset within 1 second. NOTE: Reverts the factory-configured username to admin and password to extron .	Performs a complete reset to factory defaults (with the exception of the firmware): <ul style="list-style-type: none"> Does everything mode 4 does. Resets all settings with the exception of factory firmware. Resets all IP options. Removes all files from the unit. Removes the initial serial number passwords and sets them to <i>extron</i>. The Reset LED blinks four times in succession during the reset.	For starting over with configuration and uploading or to replace events. Same as the Esc]ZQQQ← SIS command on page 64.

Performing mode 4 and 5 resets

Perform resets of the unit as follows (see figure 9):

- Use a small screwdriver to press and **hold** the rear panel **Reset** button until the rear panel **Reset** LED blinks either:
 - Twice, for an IP settings reset
 - Three times for an absolute (factory) reset

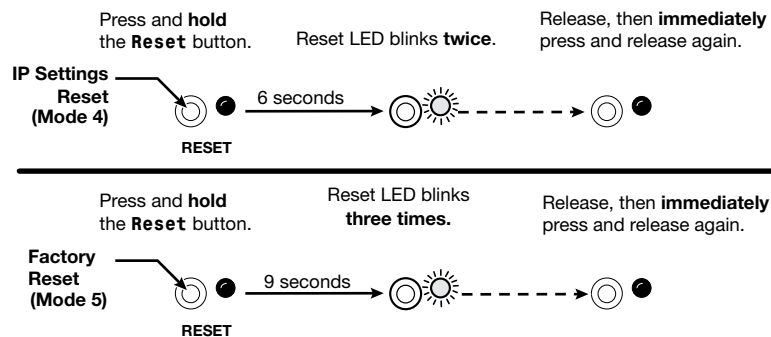

Figure 9. Resets

- Release the **Reset** button and then immediately press and release the **Reset** button again. Nothing happens if you do not momentarily **Reset** within 1 second.

HTML Operation

This section introduces using the built-in HTML pages to configure and operate the NAV E 501 and NAV E 101 encoders, including:

- [Opening the Embedded HTML Pages](#)
- [Using the HTML Pages](#)

The encoder can be controlled and operated through either the front panel Configuration (USB) port (see [figure 8](#), [B](#) on page 11) or the rear panel NAV 1G/PoE+ port (see [figure 2](#), [G](#) on page 5). The Configuration port uses IP over USB technology. The factory-embedded HTML pages are always available and cannot be erased or overwritten.

Opening the Embedded HTML Pages

Access the encoder using HTML pages as follows:

1. Start the web browser.

NOTES:

- Extron recommends the following browsers to fully support the NAV system:
 - Google Chrome™ — All screen images in this guide use Chrome
 - Mozilla™ Firefox™
 - Microsoft Edge™
- The network must be properly configured for multicasting (IGMP). Failure to do so may result in degraded performance.

2. Click in the **Address** field of the browser and enter the IP address.

NOTES:

- For the NAV/PoE+ port, if unit does not receive an IP address from the DHCP server, it self-assigns a Link Local IP address in the range 169.254.X.X.

- **Default settings:**

Port	DHCP	IP address	Subnet mask
Config (USB)*		203.0.113.22	
NAV 1G/PoE+ (RJ-45)	On		

* **For the Config port**, the address for IP over USB **CANNOT** be changed.

- If you use IP over USB, Extron recommends waiting a minute after plugging in the cable for your PC to identify the USB connection as a valid Ethernet port.

3. Press the keyboard <Enter> key.

NOTES:

- If you do not have the trusted SSL Certificate, the browser displays a privacy notification (see figure 10). Continue to the login dialog box as follows:
 1. Click the browser button that advances past the privacy notification (such as **Advanced** [1] in Chrome). Explanatory text and a link appear.

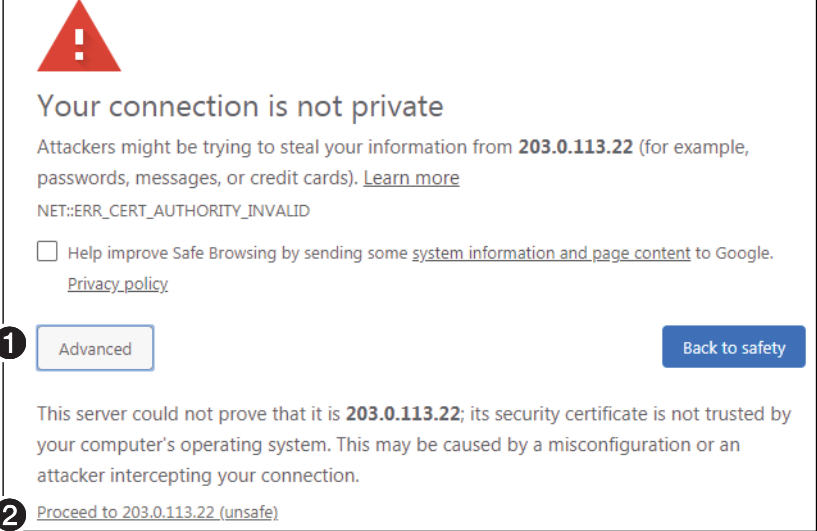

Figure 10. Privacy Notification

2. Click **Proceed to <IP address> (unsafe)** (2) (or similar message).
- Your IT department can provide an uploadable SSL Certificate (see **Toolbelt** on page 57). Once the certificate is loaded, the notification does not occur.

The browser opens to the **Log in** dialog box (see figure 11).



Figure 11. Login Dialog Box

4. Enter the **Username** (see figure 11, 1) and **Password** (2) and click **Sign In** (3). The browser opens the embedded encoder web pages (see **figure 12** on page 18).

NOTES:

- The factory configured passwords for all accounts on this device have been set to the device serial number. In the event of a complete system reset, the passwords revert to the default.
- The default username is `admin` and the default password is `extron`.
- Passwords are case sensitive.

NOTES: The HTML page may open with any of the panels (items 2 through 7 below) selected.

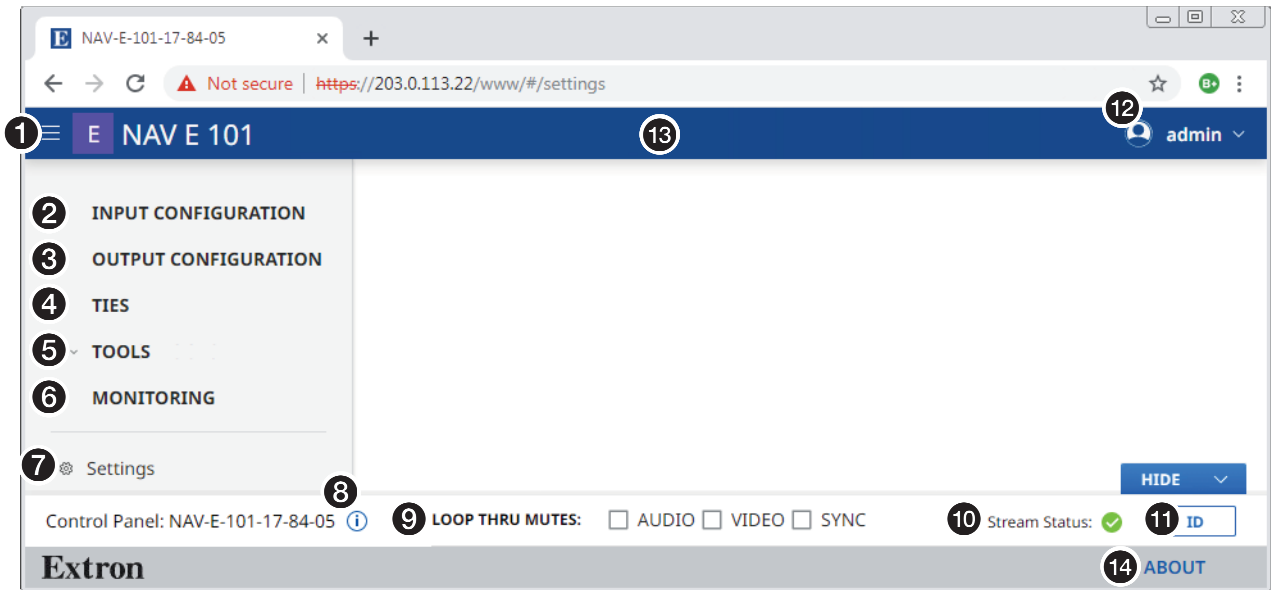
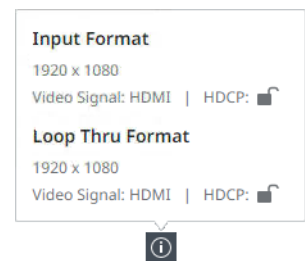

Figure 12. Home Page

Using the HTML Pages

See [figure 12](#) on page 18 and the following sections for detailed descriptions of the following pages or functions:

- ❶ **Menu icon** — Toggles to hide or show the links pane (items ❷ through ❹).
- ❷ **Input Configuration link** — Opens a page that provides input configuration information and the ability to change some input values (see [Input Configuration Page](#) on page 20).
- ❸ **Output Configuration link** — Opens a page that provides streaming output configuration information and the ability to change some output values (see [Output Configuration Page](#) on page 23).
- ❹ **Ties link** — Opens a page that displays the status of the input to the encoder and the streaming output (see [Ties Page](#) on page 31).
- ❺ **Tools link** — Opens two pages that provide encoder and diagnostic tools (see [Tools Page](#) on page 32).
- ❻ **Monitoring link** — Opens a page that shows device status information (see [Monitoring Page](#) on page 40).
- ❼ **Settings link** — Opens a page that provides access to many system settings (see [Settings Page](#) on page 45).
- ❽ **Control Panel Information indicator** — Opens a dialog box that displays the format, resolution, and rate of the input and Loop Thru output. Click anywhere outside the dialog box to close the box.



- ❾ **Loop Thru Mutes panel** — Select (click) **Audio**, **Video**, or **Sync** to toggle the mute on (do not output) and off (output) for the associated plane.

LOOP THRU MUTES: AUDIO VIDEO SYNC

NOTE: The mute function is for the Loop Thru port output only (see [item B](#) on page 5). Video, audio, and sync are still streamed to the AV network.

- ❿ **Stream Status indicator** — Displays the AV stream output status of the encoder, active (🟢), not active (🟡), or error (🔴).
- ⓫ **ID button** — Click to show the Status OSD on the Loop Thru port (see [item B](#) on page 5) and light the front panel ID LED (see [item G](#) on page 12).
- ⓬ **admin link** — Click to display the **Sign Out** button. Click **Sign Out** to log out of the encoder HTML pages.

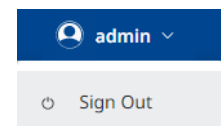

NOTES:

- The log in to the HTML pages automatically times out after 30 minutes of user inactivity.
- Signing out is disabled when the encoder is accessed via proxy from another device (see the [NOTE](#) on page 32).

- ⓭ **Name banner** — Normally displays the host name. Resting a cursor over this banner changes the display from host name to the device name.
- ⓮ **About link** — Opens a pane that provides information about the encoder (see [About Page](#) on page 56).

Input Configuration Page

Access the Input Configuration page (see figure 13) by clicking the link on the left side of the browser (❶). The browser displays the Input Configuration panel (❷).

Control Panel: NAV-E-101-17-84-05 ⓘ LOOP THRU MUTES: AUDIO VIDEO SYNC Stream Status: ✔

Figure 13. Input Configuration Page

The Input Configuration page consists of two read-only panes, Video (❸) and Audio (❹) that display the status of the input to the encoder.

The HDCP Authorized and EDID settings are accessible to change from the Video pane and the audio selected for input is accessible from the Audio pane by clicking the **Edit** link (❺) in the appropriate pane. The selected pane opens (see [Video pane](#) on page 21 and [Audio pane](#) on page 22).

TIP: Level meters (A) may help prevent overdriving the audio. The meters are present only when analog audio is being streamed (see [Audio pane](#)).

Video pane

If you change any of the settings in the **Video Input Configuration** dialog box (see figure 14, ❶ through ❹), the **Save** button (❺) becomes selectable. Click **Save** to take changes or **Cancel** (❻) to abandon them. Clicking either button closes the dialog box.

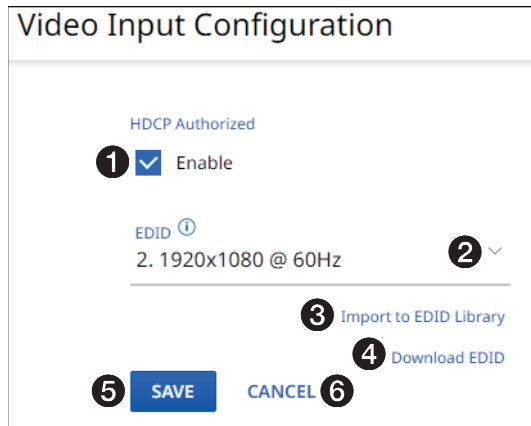

Figure 14. Video Input Configuration Dialog Box

- ❶ **HDCP Authorized** — Click to toggle **HDCP Authorized** on and off. HDCP Authorized is used to communicate to the source devices that do not support HDCP.

This helps with devices like Apple TV® that always encrypt the output even when not displaying HDCP content.

NOTE: When **HDCP Authorized** is selected the encoder communicates to the source device that it supports HDCP encrypted content. When deselected the encoder indicates that it does not support HDCP. If the source is unable to decrypt its output, the encoder generates a green screen.

- ❷ **EDID** — Click the drop-down list to select among the available EDIDs. When an EDID is selected, the encoder sends this information to the source, which adjusts its AV output to the EDID. The table below details the default encoder EDIDs. All EDIDs shown are HDMI format with 2-channel audio.

Slot	Resolution	Slot	Resolution
1	1280x720@60 Hz	5	3480x2160@60 Hz
2	1920x1080@60 Hz*	6	Loop-thru monitor
3	1920x1200@60 Hz	7	Decoder output
4	3480x2160@30Hz	8	User EDID slot

* Default

- ❸ **Import to EDID Library** — Click to import a custom external EDID to the encoder EDID library, slot 8 if the EDID supplied by the encoder does not met your needs.

NOTE: Import to EDID library (❸) is disabled when the encoder is accessed via proxy from another device (see the **NOTE** on page 32).

- ❹ **Download EDID** — Click to download the currently-selected EDID to the connected computer to save it for use in other encoders. This feature is typically used when EDID slot 6 (loop-thru monitor) or 7 (decoder output) is selected to save the EDID from a connected display.

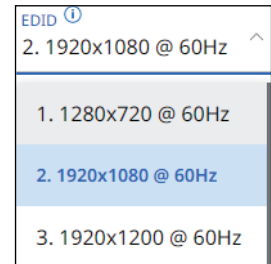

Audio Pane

If you change any of the settings in the **Audio Input Configuration** dialog box (see figure 15, ❶ and ❷), the **Save** button (❸) becomes selectable. Click **Save** to take changes or **Cancel** (❹) to abandon them. Clicking either button closes the dialog box.

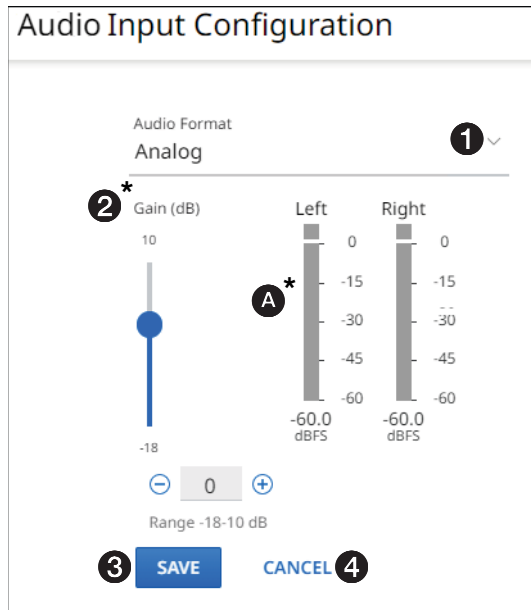

* The Gain controls and level meters are present only when analog audio is being streamed.

Figure 15. Audio Input Configuration Dialog Box

❶ **Audio Format** — Click the drop-down list to select among the following:

- **Auto Detect** — Stream the active audio input, with audio embedded in the input HDMI having priority. If there is no embedded HDMI audio, and if no analog audio is connected, the audio stream stays silent.
- **HDMI** — Stream the digital audio embedded in video. Analog audio is not streamed.
- **Analog** — Stream the analog audio on the captive screw input. Digital audio is not streamed.

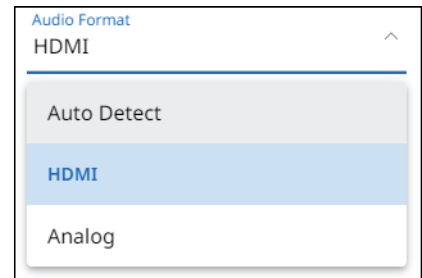

❷ **Gain** — Adjust the audio gain or attenuation value from +10 dB to -18 dB in one of three ways:

- Click and drag the fader control.
- Click the ⊖ and ⊕ buttons.
- Directly type a rate into the field.

NOTE: The level meters (A) are present only when analog is selected, either manually (**Analog**) or **Auto Detect**.

TIP: Watching the level meters may help prevent overdriving the audio.

Output Configuration Page

Access the Output Configuration page (see figure 16) by clicking the link on the left side of the browser (1). The browser displays the Output Configuration panel (2).

The screenshot shows a web browser window with the URL <https://203.0.113.22/www/#/outputConfiguration>. The page title is "NAV E 101" and the user is logged in as "admin". The page is divided into two main sections: "INPUT CONFIGURATION" and "OUTPUT CONFIGURATION". The "OUTPUT CONFIGURATION" section is active and contains five panes, each with a table of settings and an "EDIT" button.

- Stream (3):**

Bitrate (Mbps)	850
Avg Video Bitrate (Mbps)	11.64
Avg Audio Bitrate (Mbps)	2.69
Video Stream	Enabled
NAV Audio Stream	Enabled
AES67 Stream	Disabled
- Loop Thru (4):**

Display EDID	1920x1080
HDCP Mode	Follow Input
Video Output	Auto
Color Bit Depth	Auto
HDCP Notification	Enabled
Allow Audio Only	Disabled
- Test Pattern (5):**

Audio Test Pattern	Disabled
Video Test Pattern	Disabled
- AES67 Audio (6):**

Audio Address	239.69.4.6
Audio Port	5004
- On Screen Display (OSD) (7):**

OSD Type	Disabled
OSD Duration	30
Screen Saver Mute	Disabled
Screen Saver Duration	501 Always on
Background Image Selection	Black Screen

At the bottom of the page, there is a "Control Panel" section with the following information:

- Control Panel: NAV-E-101-17-84-05
- LOOP THRU MUTES: AUDIO VIDEO SYNC
- Stream Status: ✔ [ID](#)

The Extron logo is visible in the bottom left corner, and the "ABOUT" link is in the bottom right corner.

Figure 16. Output Configuration Page

The Output Configuration page consists of five panes, Stream (3), Loop Thru (4), Test Pattern (5), AES67 Audio (6), and On Screen Display (OSD) (7) that display the status of the streamed output.

Each pane has settings that can be changed by clicking the **Edit** link (see [figure 16, ⑧](#) on page 23) in the appropriate pane. The selected dialog box opens (see “Stream pane” below, [Loop Thru pane](#) on page 25, [Test Pattern pane](#) on page 26, and [AES67 Audio](#) on page 27, and [On Screen Display \(OSD\) pane](#) on page 28).

Stream pane

If you change any of the settings in the **Stream Configuration** dialog box (see figure 17, ① through ④), the **Save** button (⑤) becomes selectable. Click **Save** to take changes or **Cancel** (⑥) to abandon them. Clicking either button closes the dialog box.

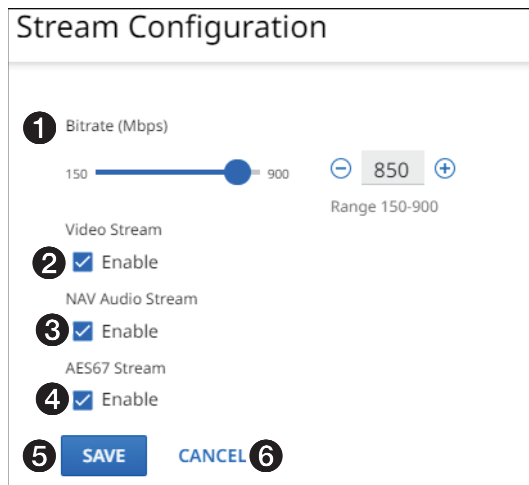

Figure 17. Stream Configuration Dialog Box

① **Bitrate** — Set the **Bitrate** in one of three ways:

NOTE: Extron recommends leaving the bitrate at the default setting, 850 Mbps. The bitrate is the rate at which the encoder transmits data. The bitrate affects the video image quality. Decreasing the bitrate lowers the quality, increasing the bitrate improves the quality.

- Click and drag the fader control.
- Click the \ominus and \oplus buttons.
- Directly type a rate into the field.

② **Video stream** — Click to toggle **Video Stream** on (stream video) and off (do not stream).

③ **NAV Audio Stream** — Click to toggle **NAV Audio Stream** on (stream NAV audio) and off (do not stream).

NOTE: NAV Audio can only be routed to other Extron NAV products. Select **NAV Audio** only when your system is interfacing solely with other NAV products and the audio needs minimal processing.

④ **AES67 Audio Stream** — Click to toggle **AES67 Audio Stream** on (stream AES67 audio) and off (do not stream).

NOTE: The AES67 standard allows for interoperability among AES67 capable devices. Enabling AES67 audio allows the device to transmit a audio stream to a third-party AES67 capable receiver.

Loop-Thru pane

If you change any of the settings in the **Loop Thru Configuration** dialog box (see figure 18, ❶ through ❺), the **Save** button (❻) becomes selectable. Click **Save** to take changes or **Cancel** (❼) to abandon them. Clicking either button closes the dialog box.

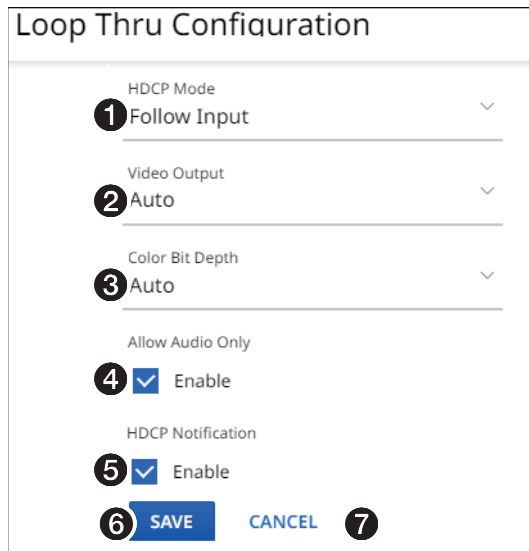
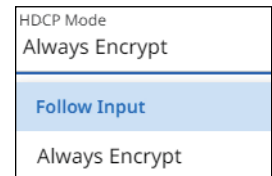

Figure 18. Loop Thru Pane

- ❶ **HDCP Mode** — Click the drop-down list to select between the following two output modes for the Loop Thru port (see [item B](#) on page 5).
- **Follow Input** — Mimics the HDCP encryption state of the connected source.
 - **Always Encrypt** — Maintains the HDCP encrypted state with the output sink device to improve system switching performance.



- ❷ **Video Output** — Click the drop-down list to select among the various output formats and colorspace for the Loop Thru port ([item B](#)). The table below shows the available formats.

Format	Format
Auto (based on the EDID of the sink [default])	HDMI YUV 444 Full
DVI RGB 444	HDMI YUV 444 Limited
HDMI RGB 444 Full	HDMI YUV 422 Full
HDMI RGB 444 Limited	HDMI YUV 422 Limited

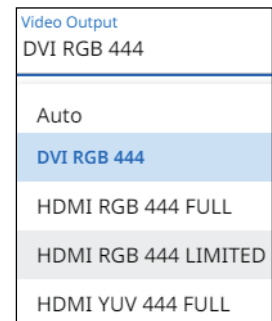

- ❸ **Color Bit Depth** — Click the drop-down list to select between the following two output formats for the Loop Thru port ([item B](#)).
- **Auto** — Adjusts color bit depth based on the display EDID to supports 10 bit or 8 bit (**default**).
 - **Force 8-Bit** — Always uses 8 bit output.

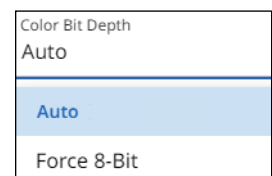

- ❹ **Allow Audio Only** — Click to toggle **Audio Only** on and off. **Audio only** prevents a display with no video source from going to standby by generating a blackburst signal.

NOTE: Allow Audio Only must be disabled to use a screen saver.

- 5 **HDCP Notification** (see [figure 18](#) on page 25)— Click to toggle **HDCP Notification** on and off. This selection lets you select what is displayed on the HDMI output when the input signal contains HDCP-protected content and the output is a non-HDCP sink.

When **HDCP Notification** is checked, a green screen is generated to clearly indicate an HDCP issue has been encountered. When **HDCP Notification** is unchecked, a black screen is generated to discretely show there is a HDCP issue.

This feature has no effect on the functionality of HDCP. Extron recommends leaving **HDCP Notification** enabled to easily know when a HDCP issue has occurred.

Test Pattern pane

If you change the test pattern setting (see [figure 19](#), 1 or 2), the **Save** button (3) becomes selectable. Click **Save** to take change or **Cancel** (4) to abandon it. Clicking either button closes the dialog box.

Test patterns aid in preliminary set-up of the AV system and are useful to test AV streams during initially configuration and when sources are not present.

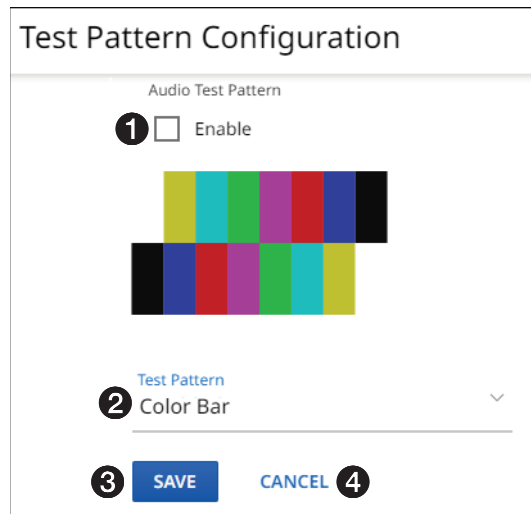
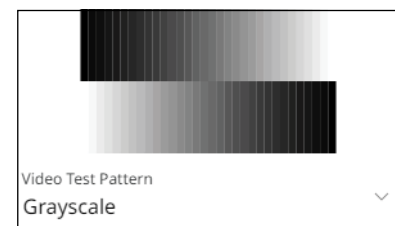

Figure 19. Test Pattern Pane

- 1 **Audio Test Pattern** — Select (click) to toggle the audio test pattern, a 400 Hz sine wave, on and off.
- 2 **Test Pattern** — Click the drop-down list to select among test patterns to display on the Loop Thru (see [item B](#) on page 5) and streamed outputs:
- **Disabled** (no test pattern)
 - **Color Bar**
 - **Grayscale**



AES67 pane

If you change the audio address setting (see figure 20, ❷), either directly or by **Reset to Default** (❶) the **Save** button (❸) becomes selectable. Click **Save** to take change or **Cancel** (❹) to abandon it. Clicking either button closes the dialog box.

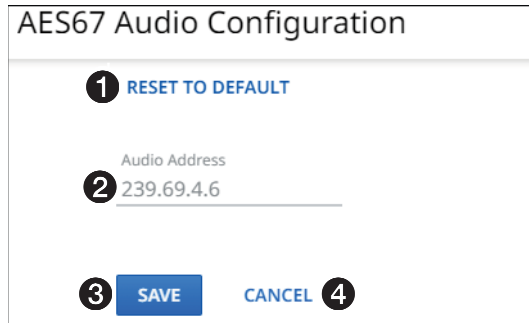

AES67 Audio Configuration

❶ RESET TO DEFAULT

Audio Address

❷ 239.69.4.6

❸ SAVE CANCEL ❹

Figure 20. AES67 Pane

- ❶ **Reset to Default** — Click this link to return the **Audio Address** (❷) to the factory default value, 239.69.xxx.xxx where the last two octets (xxx.xxx) are based on the encoder MAC address.
- ❷ **Audio Address** — Click in the **Audio Address** field and directly enter a new address as necessary.

On Screen Display (OSD) pane

This pane shows the options for the OSD and screen saver on the Loop Thru (see [item B](#) on page 5) and streamed outputs. If you change any setting, either directly or by clicking **Reset** (see figure 21, [7](#)), the **Save** button ([5](#)) becomes selectable. Click **Save** to take change or **Cancel** ([6](#)) to abandon the changes. Clicking either button closes the dialog box.

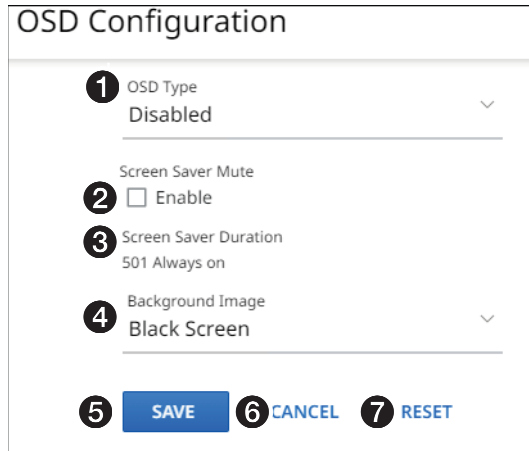





Figure 21. OSD Configuration Pane

1 OSD Type — Click the drop-down list to select among the OSD options for display. See [figure 22](#) on page 29 for typical on-screen displays.

- **Input OSD** (input connection details that can alert users of an input change.)
- **Status OSD** (general encoder details)
- **Disabled** (no OSD)

OSD Type
Input OSD
Input OSD
Status OSD
Disabled

NOTE: When **Input OSD** or **Status OSD** is selected, an extra control, **OSD Duration** appears below OSD Type.  Click  or  to increment or decrement the duration (from **1** to **500** in seconds) of how long the OSD stays active. **501** is always on.

2 Screen Saver Mute — Click to toggle the **Screen Saver Mute** on (muted) and off (unmuted) for the Loop Thru (see [item B](#) on page 5) and streamed outputs. This control sets whether the screen immediately enters low power mode (screen saver is muted) upon loss of sync or displays the user-entered background image (see **Background Image**, [4](#)) for a period of time set by the **Screen Saver Duration** setting, [3](#).

NOTE: Allow Audio Only (see [Allow Audio only](#), [4](#), on page 25) must be disabled to use a screen saver.

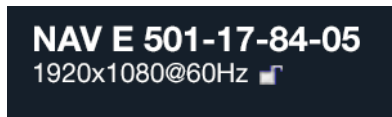

Typical Input Display

* NAV E 501 only

Extron		NAV E 501
Host Name	NAV-E-501-17-84-05	
Input Number	1982	
IP Address	192.168.1.223	
MAC Address	00-05-A6-17-84-05	
Model	NAV E 501	
Serial Number	A27YDP2	
Firmware	FW: 1.00.0006.b040	
NAV Output		
Video Stream	Active	
Audio Stream	Active	
AES67 Stream	Active	
*USB		
*USB Stream		
Input	1920x1080@ 60Hz	Output 1920x1080

Typical Status Display

Figure 22. Typical On-Screen Displays

- 3 **Screen Saver Duration** (see [figure 21](#) on page 28, available when **Screen Saver** [2] is selected) — Click in the **Duration** field and edit it as desired or click + or - to increment or decrement the delay (in seconds) of how long the screen saver stays active and streaming, before muting sync to a display. The valid range is from 1 to 500 (seconds) or 501 Always on.

When **Screen Saver Mute** is unchecked (see [item 2](#), on page 28), the duration automatically becomes 501 Always on.

After the duration expires, the encoder drops the active sync, allowing the monitor to turn off or enter low power mode.

- 4 **Background Image** — Click the drop-down list to select among the images to display as the screen saver. **Retain Last Frame** displays the last frame of input data before the OSD was activated. **Black Screen** shows a black screen. **Blue Screen** shows a blue screen. **Default Image (Extron)** displays the Extron logo. **Custom Image** displays an image of your choosing.

Background Image
Default Image (Extron)
Black Screen
Blue Screen
Retain Last Frame
Default Image (Extron)
Custom Image

NOTES:

- To be available for selection, the custom image must be manually uploaded into the endpoint.
- If you select the blue screen as the screen saver, the blue screen itself streams to the decoder, but any enabled OSD does not. The OSD does output on the encoder Loop Thru port (see [item B](#) on page 5).
- A valid custom image must be in the .png file format with a maximum size of 4K (4096 x 2160).
- The custom image may be cropped but cannot be scaled. For example: if you upload a 1080p image and the output is 4K, you will see black boarders.
- If you have not already uploaded an image, the pane displays the **Select File** button (see [Upload a custom image](#) on page 30).

Custom Image

SELECT FILE

Upload a custom image

You can upload a custom image to use for the screen saver background as follows:

NOTE: A valid custom image must be in the .png file format with a maximum size of 4K (4096 x 2160).

1. On the editable OSD Configuration pane (see **On Screen Display (OSD) pane** on page 28), click the **Background Image** drop-down list and select **Custom Image** (see figure 23, ①). If you have not already uploaded an image, the pane displays the **Select File** button (②).

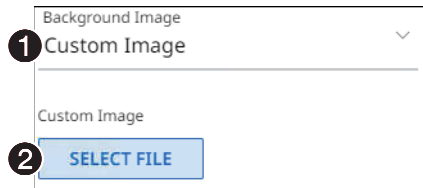

Figure 23. Upload a Custom Image, Steps 1 and 2

2. Click **Select File** (②).

An Open dialog box opens (see figure 24).

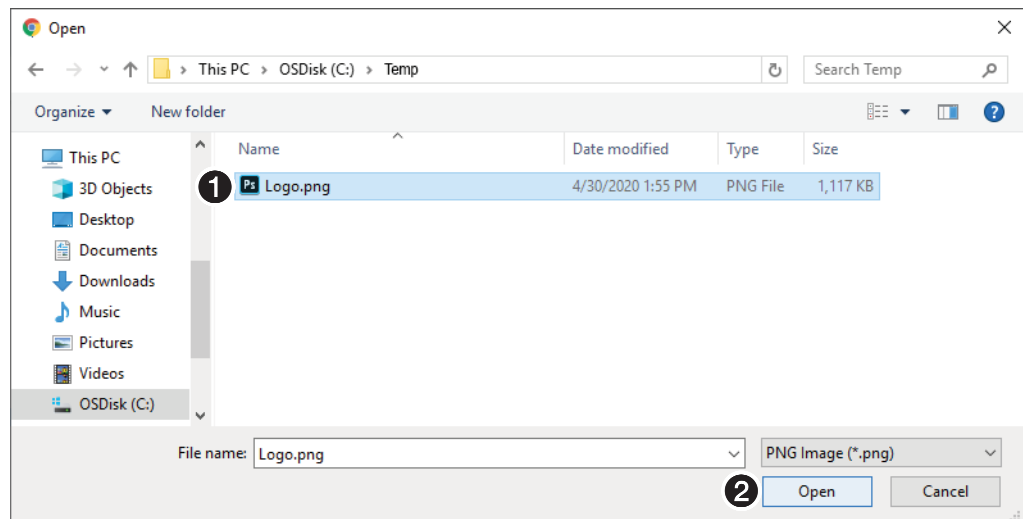

Figure 24. Open Dialog Box

3. Navigate to the folder where the image file is saved (see figure 24, ①). Select the file.
4. Click **Open** (②).

The OSD pane reports that it is uploading the image (①, at right) and then reports that it is the custom image (renamed `User_image.png`) (②).

NOTE: Click (A) to delete the image. This action is necessary to replace the custom image.



Ties Page

Access the **Ties** page (see figure 25) by clicking the link on the left side of the browser (1). The browser displays the **Ties** panel (2), which allows you to display AV ties and display and make AES67 ties and USB ties (NAV E 501 only).

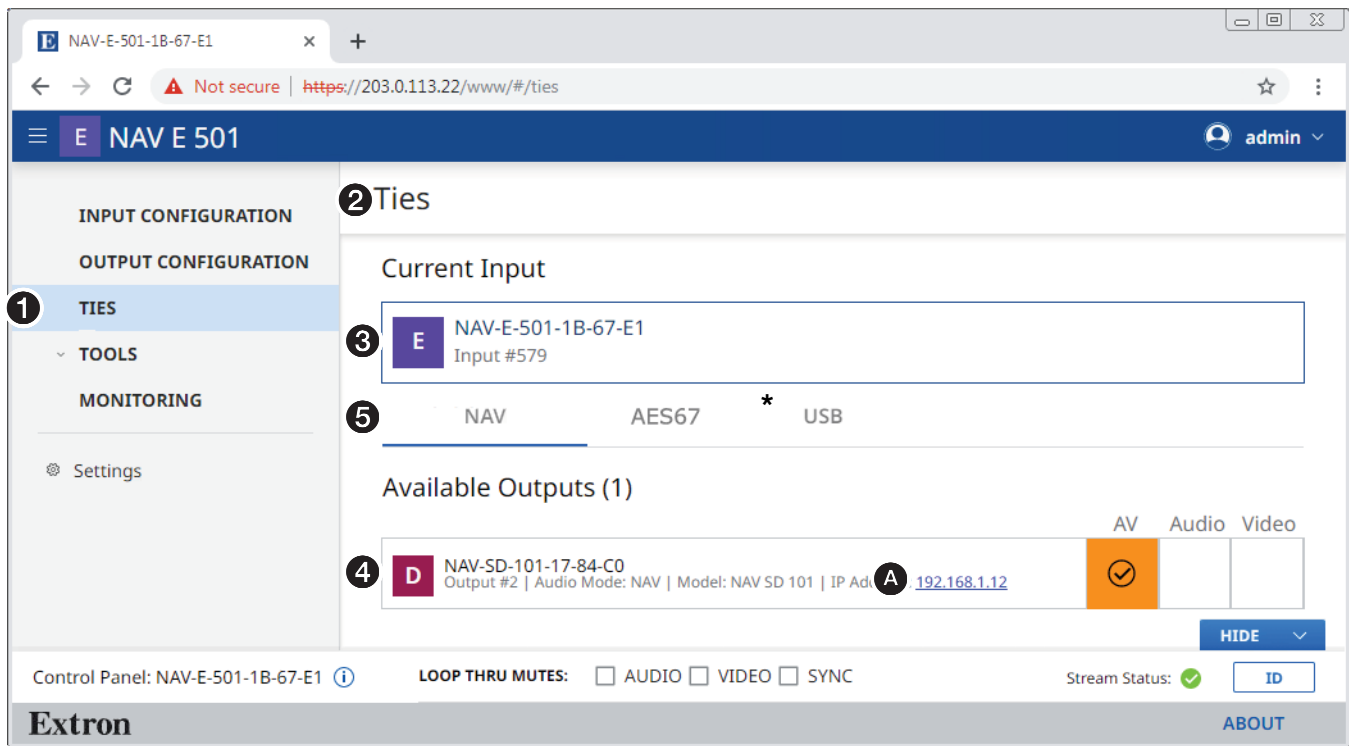

* NAV E 501 only

Figure 25. Ties Page

The **Ties** page consists of two panes, **Current Input** (3) and **Available Outputs** (4) that display the status of input and endpoints and tabs (5) that allow you to tailor the ties shown.

NOTES:

- Your tab display may differ from figure 25.
 - The AES67 tab is present only when an Extron AES67-capable device, such as a DMP 128 ProDSP Digital Matrix Processor, is tied into the NAV system. See the user guide for the applicable device to configure that device and also the Dante documentation.
 - The USB tab is present for NAV E 501 only.
- AV ties are read-only on this page.
- You can make and break AES67 and USB (NAV E 501 only) ties on this page.
- You can make and break ALL ties from the embedded HTML pages of a NAVigator or decoder (see the *NAVigator User Guide* or the applicable decoder user guide, available at <https://www.extron.com>, and the embedded HTML tie page for those devices).

Current Input pane

The **Current Input** pane displays the input number and name of the encoder to which you are connected.

Available Outputs pane

The **Available Outputs** pane (4) displays the output number, audio mode, model, and IP address of all decoders available for tying to this encoder.

NOTES:

- Also on the **Ties** page, you can open an HTML page of a connected decoder. This is a direct page to the decoder, rather than a proxied endpoint as through a NAVigator. Click the **IP Address** link in the desired output (see **figure 25**, A on page 31). The HTML page opens a new tab in the browser that is connected to the selected decoder. The decoder HTML page behaves as described in the guide for the decoder (see the applicable decoder guide available at <https://www.extron.com>).
- When you select the **AES67** tab or **USB** tab (NAV E 501 only) (see figure 26), the appearance of the **Available Outputs** pane changes. The name changes to **Available Devices** and only decoders that can receive streamed **AES67** or USB and **AES67** or USB ties are shown.

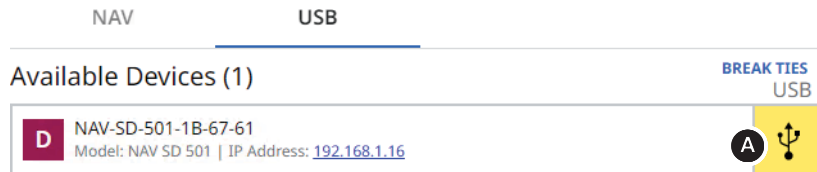
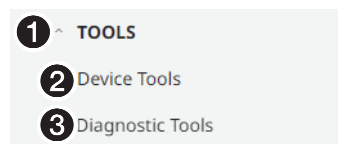

Figure 26. Available Devices for USB Tab

- To tie AES67 or USB from this encoder to a decoder, select that tab and click the desired decoder (**Available Device(s)**[see figure 26, A]). An AES67 audio tie is indicated in red and a USB tie is included in yellow. Click in an existing tie to untie it.

Tools Pages

The **Tools** pages provide tools for the encoder (**Device Tools**) and a tool for diagnosing communications (**Diagnostic Tools**). To access the **Settings** pages, if necessary, click the **Menu** link (see **figure 12**, 1 on page 18). Click **Tools** (see 1 at right) and either **Device Tools** (2) or **Diagnostic Tools** (3). The browser displays the selected **Tools** page (see **figure 27** on page 33, which shows the **Device Tools** page selected).



Device Tools page

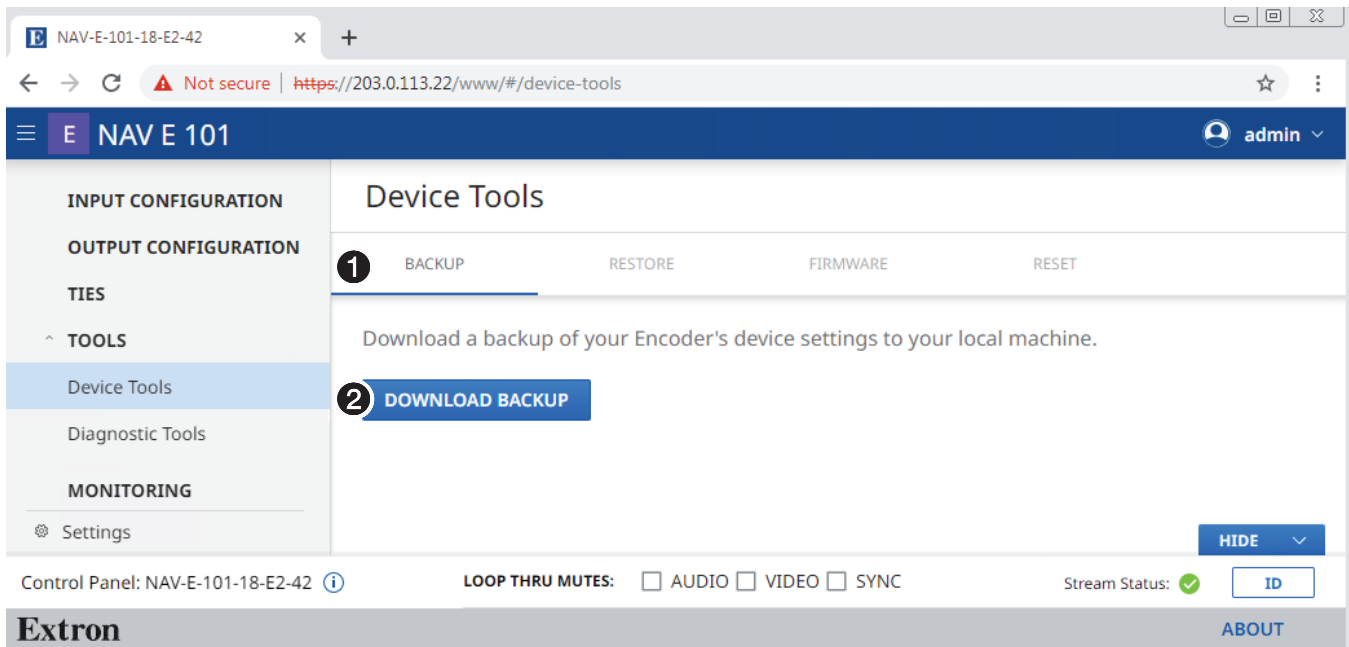

Figure 27. Device Tools Page

The Tools page consists of four tabs (see [figure 27](#), [1](#) on page 32), Backup (see “Backup tab,” below) Restore (see [Restore tab](#) on page 34), Firmware (see [Firmware tab](#) on page 36) and Reset (see [Reset tab](#) on page 37) that provide encoder tools.

NOTE: System backup, restore, firmware update, and reset are available from the NAVigator (see the *Navigator User Guide*, available at <https://www.extron.com>).

Backup tab

Backup the encoder settings as follows:

NOTE: Backup is disabled when the encoder is accessed via proxy from the NAVigator.

1. On the Device Tools page, click **Backup** (see [figure 27](#), [1](#)).
2. Click **Download Backup** ([2](#)).

The encoder creates a file of current settings and, depending on your browser, may prompt you to confirm that you want to save them.

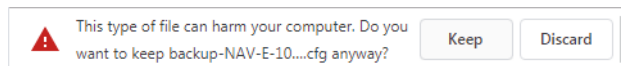

NOTE: Unless otherwise directed, the encoder backup file goes to the Downloads folder of the connected PC.

3. Click **Keep** to save the file to the Downloads folder or **Discard** as desired.

Restore tab

Restore the encoder settings as follows:

NOTE: Restore is disabled when the encoder is accessed via proxy from the NAVigator.

1. On the Device Tools page, click **Restore** (see figure 28, ❶).
2. Click **Select File** (❷).

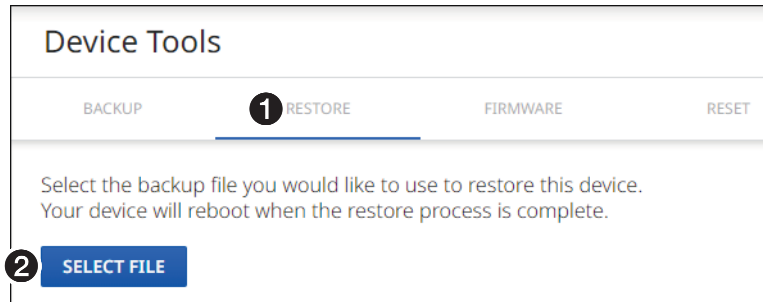

Figure 28. Tools – Restore Function

An Open dialog box opens (see figure 29).

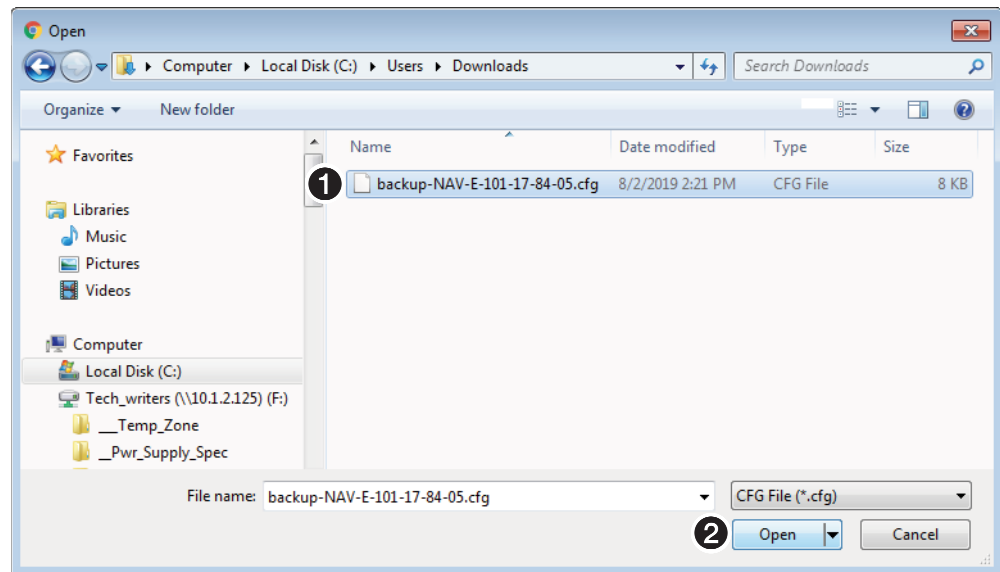

Figure 29. Open Dialog Box

3. Navigate to the folder where the Restore file is saved (typically the Downloads folder) (see figure 29, ❶). Select the file.
4. Click **Open** (❷). The Tools page returns to the top (see figure 30 on page 35).

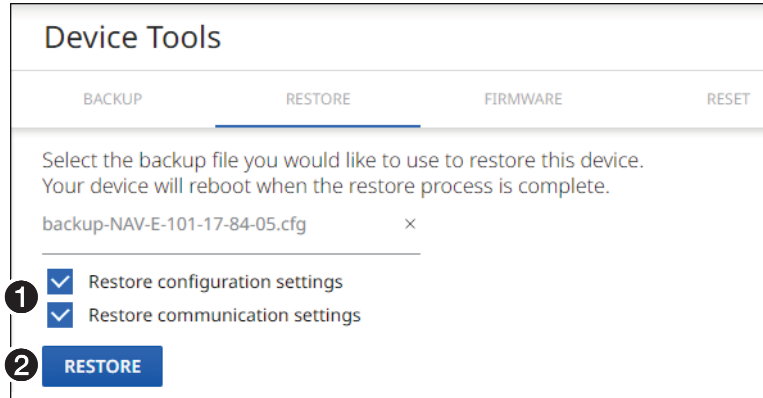

Figure 30. Tools — Restore Function, Steps 5 and 6

5. Select (click) the settings to restore (**Configuration**, **Communication**, or both; see figure 30, ❶).

Communication settings	Configuration settings	
<ul style="list-style-type: none"> • Settings > Device Details (name) • Settings > Network Connection • Settings > Ports 	<ul style="list-style-type: none"> • Settings > Device Details (location) • Settings > Date and Time • Settings > USB (NAV E 501 only) • Settings > Ports • Settings > Advanced Networking • Input Config. > Video 	<ul style="list-style-type: none"> • Input Config. > Audio • Output Config. > Stream • Output Config. > Loop Thru • Output Config > AES67 Audio • Output Config > OSD

NOTE: Account password and custom image file are not backed up.

Click **Restore** (❷).

The encoder reports that it is **Rebooting** and displays a status bar that shows the progress of the Restore operation. When the operation completes, the encoder reboots.

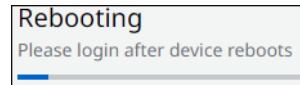

NOTE: You must reconnect to the encoder (see [Opening the Embedded HTML Pages](#) on page 16) if you have additional operations to perform.

Firmware tab

Upgrade the encoder firmware as follows:

NOTES:

- Firmware upgrade is disabled when the encoder is accessed via proxy from the NAVigator.
- Upgrading the encoder firmware results in the unit rebooting.
- Valid firmware files have the .eff file extension. Any other file extension is not a valid firmware update.

1. On the Device Tools page, click **Firmware** (see figure 31, ❶).

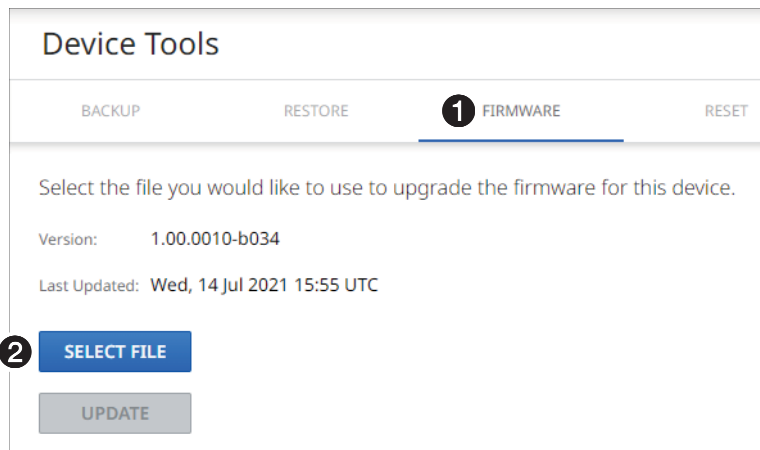

Figure 31. Tools – Firmware Function

2. Click **Select File** (❷). An Open dialog box opens (see figure 32).

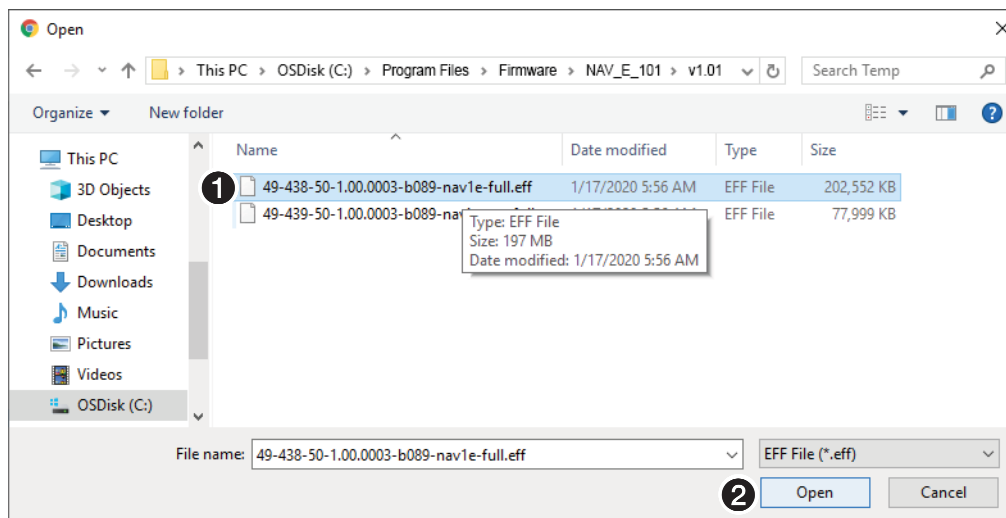

Figure 32. Open Dialog Box

3. Navigate to the folder where you saved the firmware upgrade file (see figure 32, ❶). Select the file.
4. Click **Open** (❷). The Open dialog box closes and the Tools pane returns to the top, with the selected firmware file identified (see [figure 33](#), ❶ on page 37).

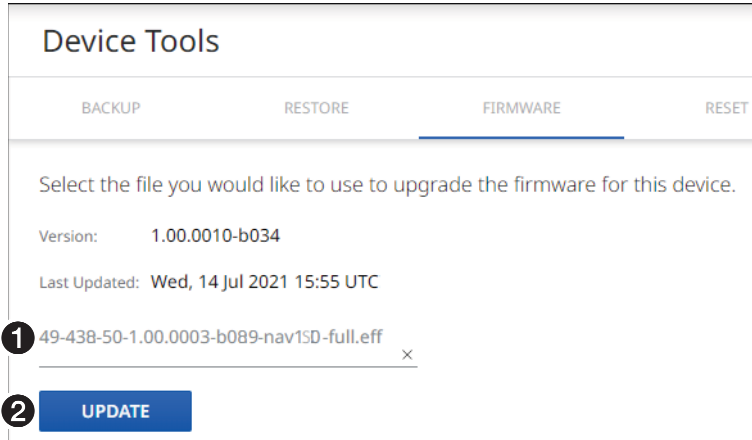

Figure 33. Device Pane with Firmware File Identified

5. Click **Update** (2).

The encoder page displays a sequence that reports the progress as it uploads the file (see figure 34, 1), updates the firmware (2), and then reboots (3).

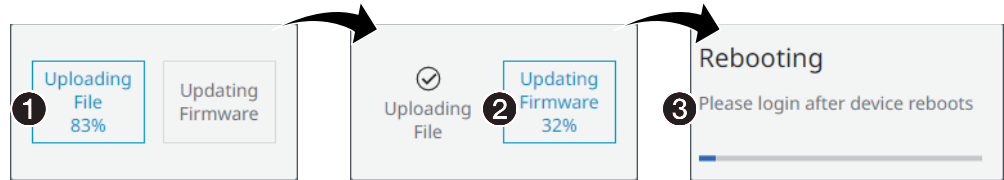

Figure 34. Firmware Upload Progress

When the encoder reboots, the connection to it is momentarily lost and after a few seconds, the browser displays the home page **Login** dialog box (see figure 11 on page 17). To continue to operate the encoder, you must reconnect (see [Opening the Embedded HTML Pages](#) on page 16).

Reset tab

Reset or reboot the encoder as follows:

1. On the Device Tools page, click **Reset** (see figure 35, 1).

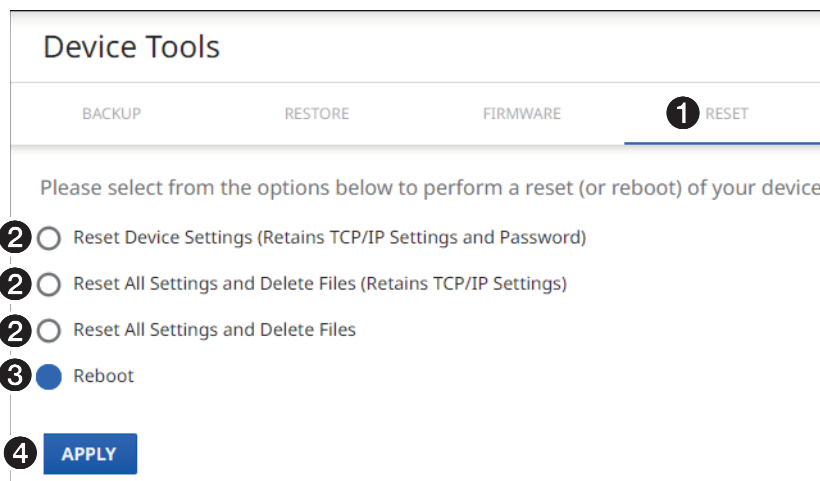

Figure 35. Tools — Reset Function

2. Select (click) a reset level (see [figure 35](#), ② on page 37) or **Reboot** (③).

NOTES:

- **Reset Device Settings (Retains TCP/IP Settings and Password)** — Resets configuration settings. All communication settings and the password are retained. See the [table](#) of communication and configuration settings on page 35.
- **Reset All Settings and Delete Files (Retains TCP/IP Settings)** — Resets configuration settings **except** the communication settings, which are maintained. Resets the password to the default, which is **extron**. See the [table](#) of communication and configuration settings.
- **Reset All Settings and Delete Files** — This reset is identical to the Mode 5 reset (see the [table](#) of rear panel reset modes on page 15), which resets all settings to factory defaults.

3. Click **Apply** (③).

The encoder reports that it is **Resetting** and **Rebooting** and displays a status bar that shows the progress of the operation. Any of these operations concludes, with the encoder rebooting.

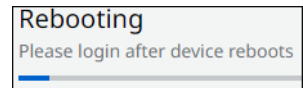
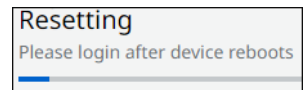

NOTE: You must reconnect to the encoder (see [Opening the Embedded HTML Pages](#) on page 16) if you have additional operations to perform.

Diagnostic Tools page

The **Diagnostic Tools** page (see figure 36) provides tools that allow you to troubleshoot the connection to other units on the NAV network. Access the page as follows:

1. Click the **Tools > Diagnostic Tools** link on the left side of the browser (❶). The browser displays the **Diagnostic Tools** page.

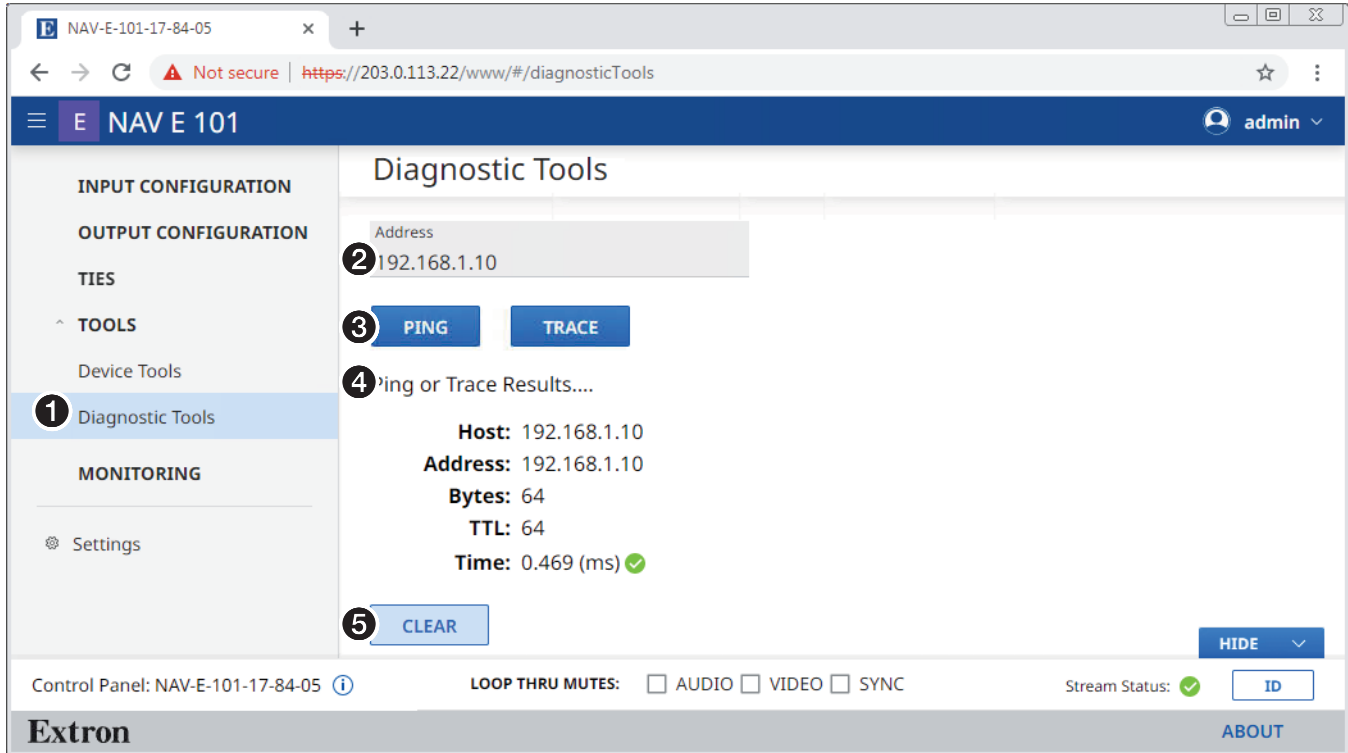

Figure 36. Diagnostic Tools Page, Ping Results Shown

2. Click in the **Address** field and type in the IP address of another unit on the network (❷).
3. Click either **Ping** or **Trace** (❸), depending on the diagnostic you want to run.

NOTES:

- **Ping** — Tests the connection to another unit on the network. Figure 36, ❹ shows the typical results of a Ping diagnostic. If you see the message **Ping to Host Address has Timed Out...**, contact your system administrator to troubleshoot.
- **Trace** — Traces the network route taken by a packet from source to destination and displays the network packet path as it traverses the network. If a trace is not fully successful, the diagnostic displays where the packet was last successful before it stopped and can no longer communicate to the next hop. Figure 37 shows the typical results of a Trace diagnostic.

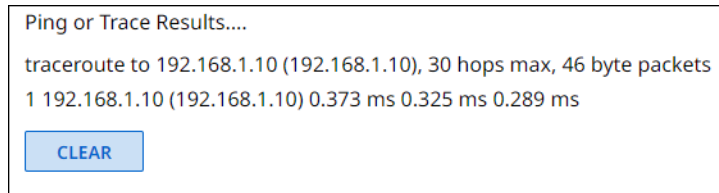

Figure 37. Trace Results Shown

4. Click **Clear** (❺) to reset the **Address** field if you want to run another diagnostic.

Monitoring Page

Access the Monitoring page (see figure 38) by clicking the link on the left side of the browser (1). The browser displays the Monitoring page (2), which shows device status information.

NAV E 501

admin

1 MONITORING

2 Monitoring

3 IGMP Querier
Discovered
192.168.1.111

4 Memory Utilization
19%
Used

5 AV LAN Utilization
TX 48%
Used
RX 0%
Used

6 Ethernet Extension Utilization
TX 0%
Used
RX 0%
Used

7 USB Devices
Connected

8 Primary Controller
System ID: 1760
Connected
192.168.0.145

9 No Alarms
There are no errors or warnings reported.

10 DOWNLOAD LOGS

Control Panel: NAV-E-501-17-84-05

LOOP THRU MUTES: AUDIO VIDEO SYNC

Stream Status: ID

Extron ABOUT

* NAV E 501 only

Figure 38. Monitoring Page

- 3 IGMP Querier
- 4 Memory Utilization
- 5 AV LAN Utilization
- 6 Ethernet Extension Utilization (NAV E 501 only)
- 7 USB Devices (NAV E 501 only)
- 8 Primary Controller
- 9 Alarms
- 10 Download Logs

- ③ **IGMP Querier pane** (see [figure 38](#) on page 40) — See “IGMP Querier pane.”
- ④ **Memory Utilization** — Indicates encoder memory usage, expressed in percent.
- ⑤ **AV LAN Utilization** — Indicates the total bandwidth usage at that moment. The encoder generates an alarm if the utilization goes above 90%. The alarm clears automatically once the level drops below 90%.

NOTE: The encoder normally uses far more Tx than Rx bandwidth.

- ⑥ **Ethernet Extension Utilization pane** (NAV E 501 only) — See “Ethernet Extension Utilization pane.”
- ⑦ **USB Devices pane** (NAV E 501 only) — See [USB Devices pane](#) on page 42.
- ⑧ **Primary Controller pane** — See [Primary Controller](#) pane on page 42.
- ⑨ **Alarms pane** — See [Alarms pane](#) on page 43.
- ⑩ **Download Logs link** — See [Download Logs link](#) on page 44.

IGMP Querier pane

An IGMP querier is a network service, usually running on a network switch, that can initiate IGMP queries. An IGMP querier should be configured on the NAV network. It manages the multicast traffic. If there is no IGMP querier on the network, there is no effective multicast traffic management and the multicast traffic saturates the network and stream and communication errors can occur.

The **IGMP Querier** pane (see [figure 38](#), ③) shows whether or not an IGMP querying device is present on the network, and the IP address of the IGMP querier. Figure 39 shows the normal indication and if no IGMP querier is present on the network.



Figure 39. IGMP Querier Pane Indications

Ethernet Extension Utilization pane (NAV E 501 only)

The **Ethernet Extension Utilization** pane (see [figure 38](#), ⑥) indicates the total bandwidth usage of the rear panel Extension port (see [figure 2](#), ④ on page 5) at that moment. The encoder generates an alarm if the utilization goes above 90%. The alarm clears automatically once the level drops below 90%. Figure 40 shows the normal indication and if the Extension port is either **disabled** (see [Network Connection](#) on page 49) or **enabled** with no device connected to it.

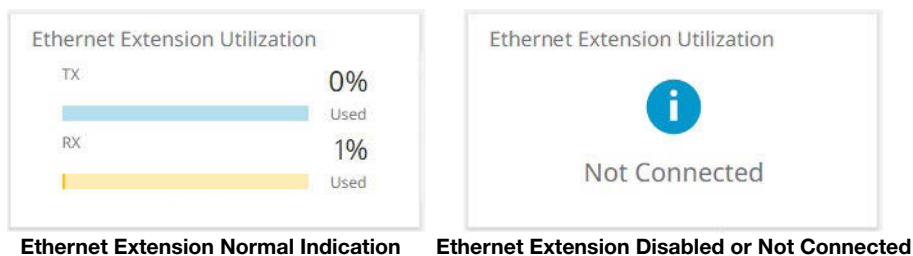

Figure 40. Ethernet Extension Utilization Pane Indications

USB Devices pane (NAV E 501 only)

The USB Devices pane (see [figure 38, 7](#) on page 40) shows whether or not one or more USB devices are connected and NAV USB extension is enabled. Figure 41 shows the normal indication and if no USB devices are connected or the USB Host has forced the USB bus into a suspend state.



Figure 41. USB Devices Pane Indications

Primary Controller pane

The Primary Controller pane (see [figure 38, 8](#)) shows whether or not an Extron control processor, such as an IPCP Pro xi Control Processor, is paired with the NAV device, and the IP address of the device if present. Figure 42 shows the normal indication and if no primary controller is present on the network available or an endpoint is not connected to any controller.

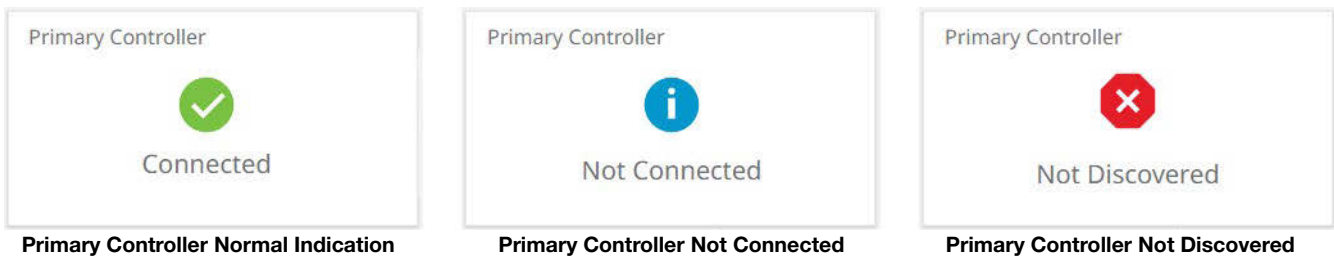

Figure 42. Primary Controller Pane Indications

Alarms pane

The Alarms pane (see [figure 38](#), ⑤ on page 40) shows any current alarms. Figure 43 shows the pane when alarm indications are present (see [Alarms](#) on page 67). Some alarms self-clear when specific conditions are met, others remain as long as the condition that causes it remains. As an example, a temperature alarm remains until the encoder cools down.

Alarms (Showing 2 of 2) ⑤ ALARM SETTINGS

① ⚠ Video Loss [LEARN MORE](#) NAV-E-101-17-84-05 03/27/20 07:26...

⚠ Device Offline 03/27/20 07:26...

Filter ▾ Sort ▾ ④ CLEAR ALARMS (1)

② <input checked="" type="checkbox"/>	TYPE	NAME	INPUT	OUTPUT	TIMESTAMP	EVENT	ISSUE
<input type="checkbox"/>	⚠				03/27/20 07:26 PM	Device Offline	The NAVigator(NAVigator-19-CC-F9) is offline
③ <input checked="" type="checkbox"/>	⚠	NAV-E-101-17-84-05	3322		03/27/20 07:26 PM	Video Loss	No video for 2 seconds or more on input 1

Figure 43. Clearing Alarms

NOTES:

- Critical alarms (🚨) should be resolved immediately.
- Warning alarms (⚠) are less serious.

Manually clear one or more alarms from the system as follows:

1. Click **Learn More** (see figure 43, ①).
2. Click the **All** checkbox (②) or individual endpoint checkboxes (③) to select one or more alarms to clear.
3. Click **Clear Alarms** (④) to clear this alarm.

Configure which alarms are and are not reported in this field as follows:

1. Click **Alarm Settings** (see [figure 43](#), ⑤ on page 43). The Edit Alarms Settings dialog box opens (see figure 44).

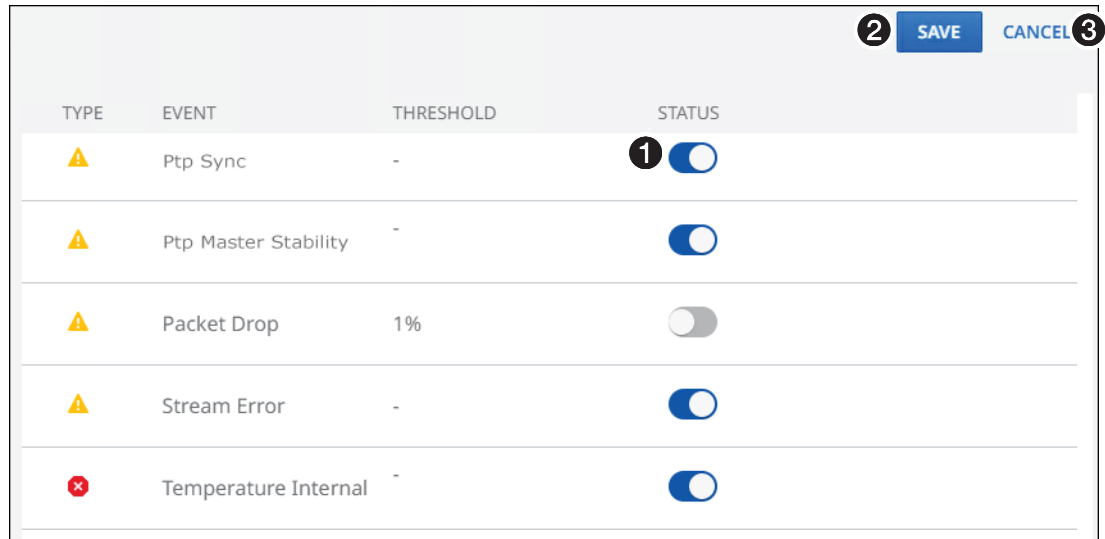
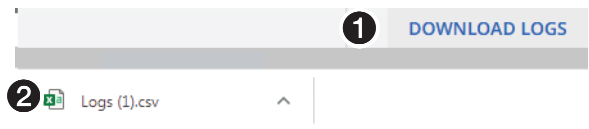

Figure 44. Edit Alarm Settings Dialog Box

2. Click the **Status** switch (①) to enable () and disable () alarm reporting.
3. Click **Save** (②) to make the changes or **Cancel** (③) to abandon them.

Download Logs

Click the **Download Logs** link (see ① at right) to download a history of errors in a comma-delimited .csv file that can be opened in Microsoft Excel. The figure at right shows the results of downloading an alarms log using the Chrome browser (②).



NOTES:

- Logs are a diagnostic tool that assists in troubleshooting or debugging. NAV devices log system changes that occur and time stamp each entry to assist in tracking the sequence of events that lead up to an issue. Logs can be reviewed to better understand the cause of failure.
- There is no upper limit to the number of alarms that can be logged, but a device can only have one alarm of the same type active at a time. The encoder monitors the active alarm states of all devices in the NAV system. All alarm state changes are logged even if status reporting is disabled from the encoder.

Settings Page

Access the **Device Settings** page (see figure 45) by clicking the link on the left side of the browser (1). The browser displays the **Device Settings** page (2), which provides access to many system settings. Click the down arrow (3) to open a selection.

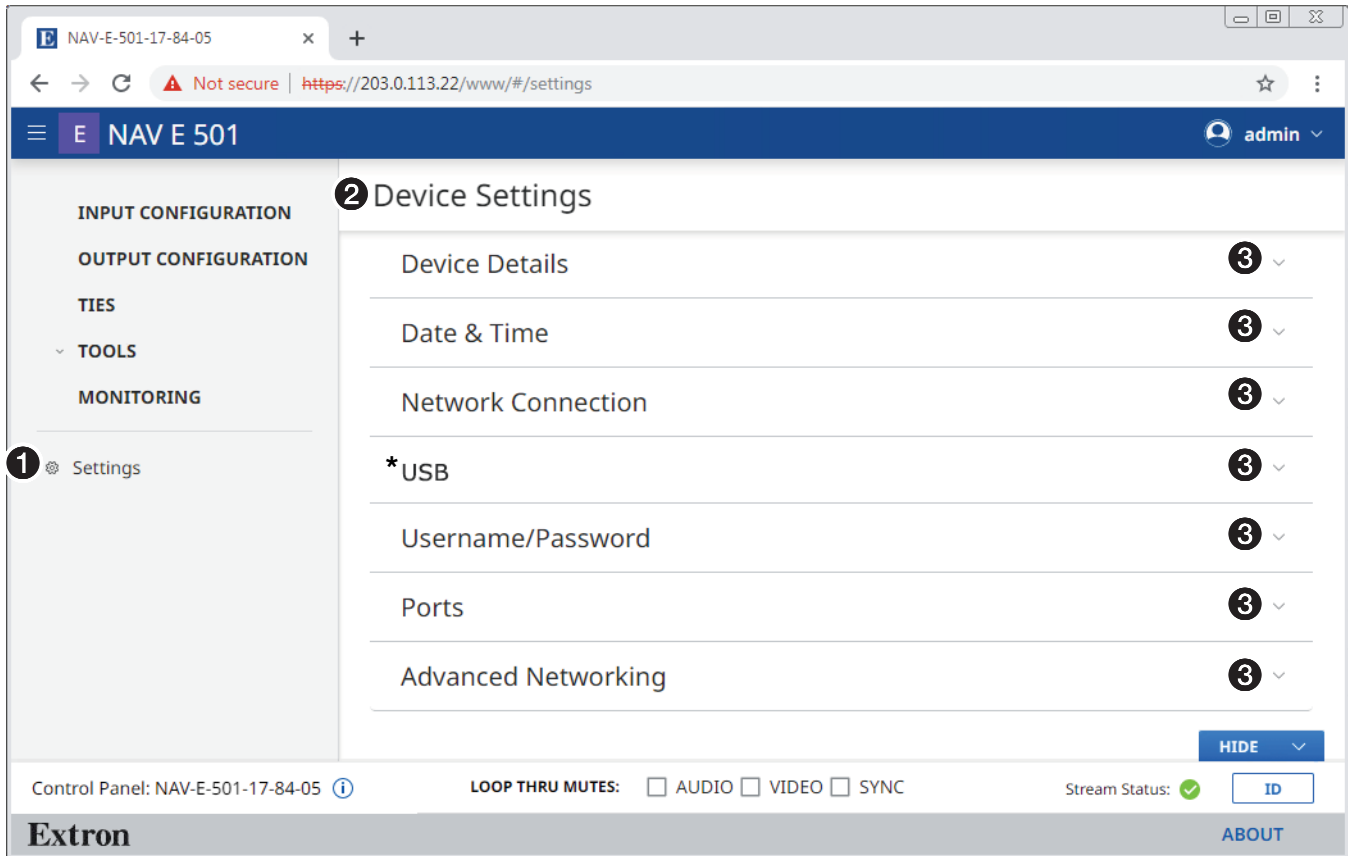

* NAV E 501 only

Figure 45. Settings Page

Device Details

The **Device Details** selection on the **Device Settings** page opens a read-only pane that shows general information unique to the encoder (see figure 46 on page 46). The **Device Name**, **Input Number**, and **Location** can be edited by clicking the **Edit** button (1). An editable version of the selection opens (see figure 47 on page 46).

NOTES:

- Editing of **Device Detail** settings is disabled and the **Edit** button is unavailable for selection when the encoder is assigned to a NAVigator.
- Special characters, which are not allowed in tags, names, and locations, are as follows: ! ~ ` @ # \$ % ^ & * () _ + = { } [] \ | : ; " ' < > , . ? and / . A hyphen (-) is not a special character.
- Tags, names, and locations each have a 63-character limit.

Tag Rules	Name Rules	Location Rules
<ul style="list-style-type: none"> • Cannot begin or end with a hyphen. • Cannot begin with a space. <ul style="list-style-type: none"> • Spaces are allowed after the first character. • Multiple tags are allowed, making filtering and sorting searching easier. 	<ul style="list-style-type: none"> • Must begin with a letter. • Cannot end with a hyphen. • Spaces are not allowed. 	<ul style="list-style-type: none"> • Must begin with a letter. • Cannot end with a hyphen. <ul style="list-style-type: none"> • Hyphens are allowed in any other position. • Cannot begin with a space. <ul style="list-style-type: none"> • Spaces are allowed after the first character.

Device Details

Device Name NAV-E-101-17-84-05	Part Number 60-1525-12
Input Number 1030	Serial Number A1YX8DN
System Manager <i>Unassigned</i>	Firmware Version 1.00.0001-b010
Location <i>Not Specified</i>	Power Source P/S
Device Type Encoder	Temperature 118.4F/48.0C
Model Name NAV E 101	Features <i>Base</i>
Model Description NAV Gigabit Encoder HDMI	

1 EDIT

Figure 46. Device Details Selection

Device Details

Device Name
1 NAV-E-101-17-84-05

Input Number
2 ⊖ 1030 ⊕
Range 1-4096

System Manager
Unassigned

Location
3 West Coast HQ

Device Type
Encoder

Model Name
NAV E 101

Model Description
NAV Gigabit Encoder HDMI

4 SAVE CANCEL

Figure 47. Editable Device Details Pane

1 Device Name — Click in this field and type in a device name of your choice.

NOTE: The Device Name is also the “hostname.”

2 Input Number — Click the ⊖ and ⊕ buttons or type a number into the field to overwrite the factory default input number, which is automatically generated in the range from 1 to 4096.

3 Location — Click in this field and type in a location to customize your system.

4 Save and Cancel buttons — Click **Save** to take Device Details changes or **Cancel** to abandon them. Clicking either button closes the editable pane.

Date & Time

The **Date & Time** selection on the **Device Settings** page (see [figure 45](#) on page 45) opens a read-only pane that shows date and time settings (see [figure 48](#)). Click **Set Manually** (❶) and **Sync with Server** (❷) to switch between the views applicable to each selection. The date and time can be edited by clicking the **Edit** button (❸). An editable pane opens (see “Set time manually” and [figure 49](#) and [Sync time with server](#) and [figure 51](#) on page 48).

NOTE: Editing of these settings is disabled and the **Edit** button is unavailable for selection when the encoder is assigned to a NAVigator.

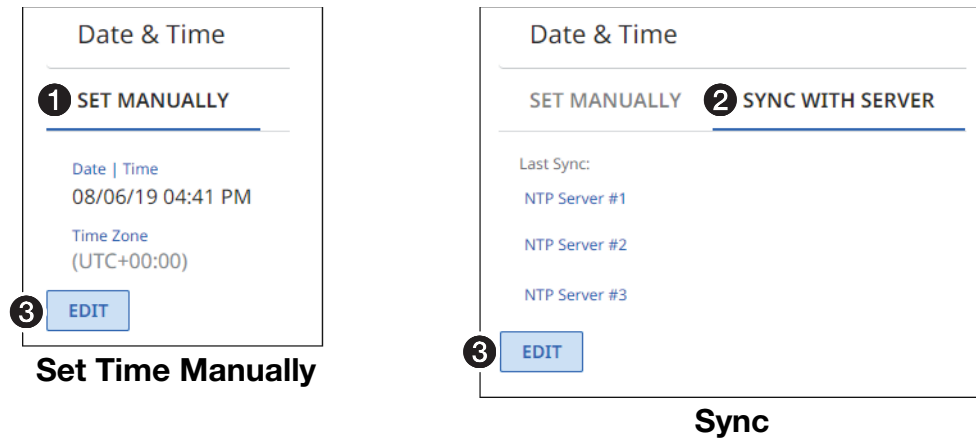

Figure 48. Date & Time Selection

Set time manually

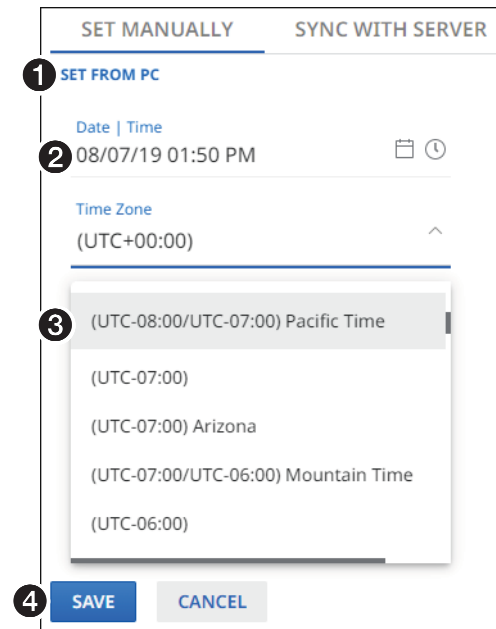

Figure 49. Set Time Manually

- ❶ **Set from PC** — Click this link to sync the encoder date and time to the computer with which you are connected.
- ❷ **Date & Time** — Click in this field and type in the date and time.
- ❸ **Time Zone** — Click the drop-down list to select the offset from Greenwich Mean Time (GMT).

- 4 **Save and Cancel buttons** (see **figure 49** on page 47) — Click **Save** to take Date & Time changes or **Cancel** to abandon them. Clicking either button closes the editable pane.

NOTE: Or you can click the **Datepicker** (📅) or **Timepicker** (🕒) icons (see figure 50) and use those tools to set the date and time.

Figure 50. Using Datepicker and Timepicker Tools

Sync time with server

Figure 51. Sync Time with Server

- 1 **Sync Now** — Click to force the encoder to sync its internal clock to an NTP server.
- 2 **NTP server** — Click in these fields and type in the IP address or DNS name of an NTP server.
- 3 **Save and Cancel buttons** — Click **Save** to take Date & Time changes or **Cancel** to abandon them. Clicking either button closes the editable pane.

Network Connection

The Network Connection selection on the Device Settings page (see [figure 45](#) on page 45) opens a read-only pane that shows the connection variables of the encoder (see [figure 52](#)). DHCP, IP Address, Subnet, Gateway, DNS Server, DNS Suffix, and Ethernet Extension can be edited by clicking the **Edit** button (❶). An editable pane opens (see [figure 53](#) on page 50).

NOTES:

- Ethernet Extension is **Off** by default.
- Editing of these settings is disabled and the **Edit** button is unavailable for selection when the encoder is assigned to a NAVigator.

Network Connection

Link Speed
1 Gbps

DHCP
On

IP Address
169.254.6.11

Subnet
255.255.0.0

Gateway
0.0.0.0

DNS Server
0.0.0.0

DNS Suffix
Not Specified

Link Local
169.254.6.11

MAC Address
00-05-A6-17-84-05

* Ethernet Extension
On

❶ **EDIT**

* **NAV E 501 only**

Figure 52. Network Connection Pane

NOTE: IP Address, Subnet, Gateway, DNS Server, and DNS Suffix are not editable when DHCP is on.

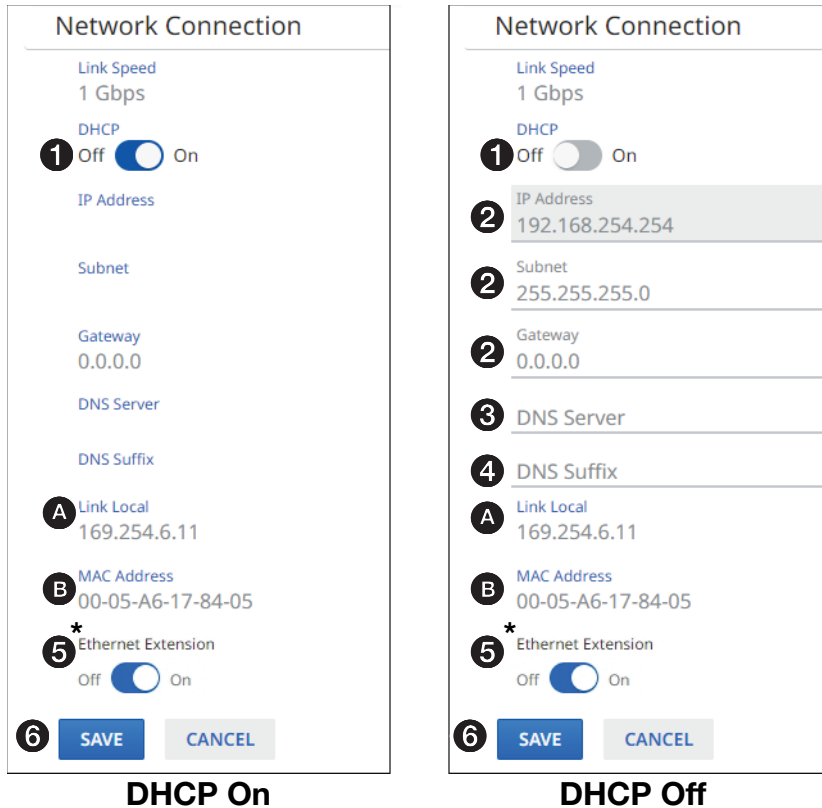

* NAV E 501 only

Figure 53. Editable Network Connection Pane

- ❶ **DHCP** — Click to toggle **DHCP** on and off. When off, the encoder defaults to the **Link Local** address (see **A**).
- ❷ **IP Address, Subnet, and Gateway** — Click in these fields and type in values to enter the appropriate connection values for your encoder.
- ❸ **DNS (Domain Name System) Server** — Click in this field and type in the name of the domain name server.
- ❹ **DNS suffix** — Click in this field and type the valid suffix of the domain name server.
- ❺ **Ethernet Extension** — Click to toggle the rear panel Extension port (see **figure 2, H** on page 5) on and off.
- ❻ **Save and Cancel buttons** — Click **Save** to take **Network Connection** changes or **Cancel** to abandon them. Clicking either button closes the editable pane.

NOTES:

- **Link Local (A)** — DHCP is on by default. When a DHCP server is not accessible, the Link local IP Address is available.
- **MAC Address (B)** — A unique read-only identifier for network connected devices.

USB (NAV E 501 only)

The USB selection on the **Device Settings** page (see [figure 45](#) on page 45) opens a read-only pane (see [figure 54](#)) that shows the status of the USB 2.0 port (see [F](#) on page 6). The port can be turned on and off and it can be configured by clicking the **Edit** button (1). An editable version of the selection opens (see [figure 55](#)).

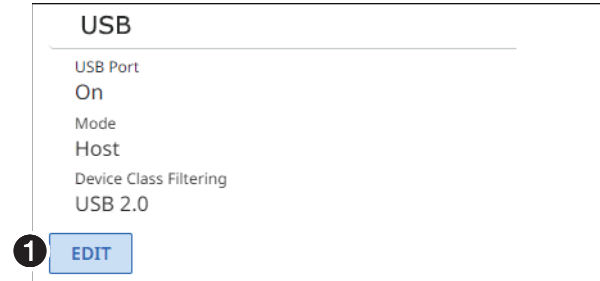

Figure 54. USB Selection

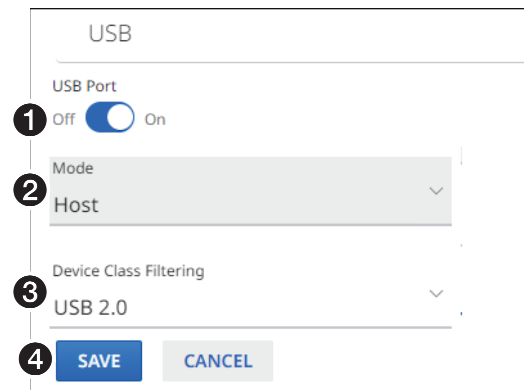

Figure 55. Editable USB Selection

1 **USB Port** — Click to toggle the port on and off.

NOTE: If you turn the USB port off, the endpoint does not appear on the **USB Ties** page.

2 **Mode** — Click the drop-down list to select between **Device** and **Host**.

NOTES:

- **Host** mode allows a host device such as a PC to be connected or accepted to that endpoint.
- **Device** mode allows devices to be connected or accepted to that endpoint.
- You can **only** tie a USB host to a USB device for proper system operation.
- Do not connect a host to an endpoint that is in USB device mode.

3 **Device Class Filtering** — Click the drop-down list to select between **USB 2.0** and **HID Only**.

NOTE: USB Device Class filtering limits the functionality of the USB port.

- **USB 2.0** - No restrictions, allows all USB devices to function.
- **HID Only** - Allows only devices such as a keyboard and mouse to function.

4 **Save and Cancel buttons** — Click **Save** to take USB changes or **Cancel** to abandon them. Clicking either button closes the editable pane.

Username/Password

The Username/Password selection on the Device Settings page (see [figure 45](#) on page 45) opens a read-only pane that shows the credentials of the encoder (see [figure 56](#)). The Password can be edited by clicking the **Edit** button (1). An editable version of the selection opens (see [figure 57](#)).

NOTES:

- Editing of these settings is disabled and the **Edit** button is unavailable for selection when the encoder is assigned to a NAVigator.
- Any devices assigned to the NAVigator inherit the password of that NAVigator.

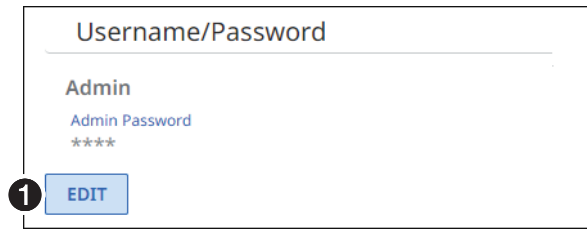

Figure 56. Username/Password Selection

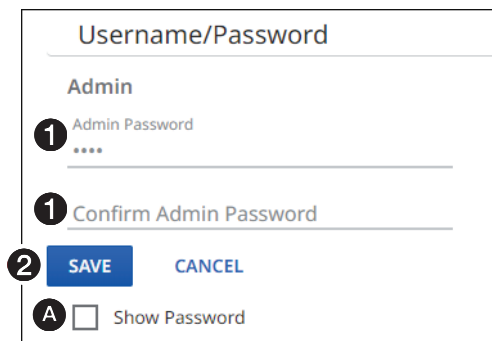

Figure 57. Editable Username/Password Selection

- 1 **Password and Confirm Password** — Click in these fields and type in valid password values to enter the appropriate values for your encoder.

NOTES:

- A valid password meets the following requirements:
 - The length is up to 64 characters.
 - All alphanumeric characters and ASCII symbols are permitted except | (pipe).
 - The password cannot be blank.
 - The password cannot start with a space.
- The factory configured passwords for all accounts on this device have been set to the device serial number. In the event of a complete system reset, the passwords revert to the default.
- The default username is `admin` and the default password is `extron`.

TIP: Select (click) the **Show Password** checkbox (A) to display the password as you type it.

- 2 **Save and Cancel buttons** — Click **Save** (2) to take Password change or **Cancel** to abandon it. Clicking either button closes the editable pane.

Ports

The **Ports** selection on the **Device Settings** page (see [figure 45](#) on page 45) opens a read-only pane that shows the port usage parameters of the encoder (see figure 58). The **HTTPS** and **RTP Start** parameters can be edited by clicking the **Edit** button (1). This feature gives the flexibility to use specific ports of your choosing, if the default ports are in use. An editable version of the selection opens (see figure 59).

Ports

HTTPS
443

RTP Start
50000

RTP End
50005

1 EDIT

Figure 58. Ports Selection

Ports

1 HTTPS
1024

1 RTP Start
50000

RTP End
50005

2 SAVE CANCEL

Figure 59. Editable Ports Selection

1 **HTTPS and RTP Start** — Click in these fields and type in valid values for your encoder.

NOTES:

- Valid HTTPS values:
 - 0 = Disabled
 - 443 = **Default**
 - 1024 - 65535 = Other available options so long as they are not overlapping on the encoder.
- Valid RTP Start values:
 - 0 - Disabled
 - 1024 - 65529 = Free use
- See the *NAV Series Pro AV Ports and Licenses Guide*, available at <https://www.extron.com>, for more information on ports.

2 **Save and Cancel buttons** — Click **Save** to take Port changes or **Cancel** to abandon them. Clicking either button closes the editable pane.

Advanced Networking

The **Advanced Networking** selection on the **Device Settings** page (see [figure 45](#) on page 45) opens a read-only pane that shows the port usage parameters of the encoder (see [figure 60](#)). The parameters can be edited by clicking the **Edit** button (❶). An editable version of the selection opens (see [figure 61](#)).

The screenshot shows a window titled "Advanced Networking" with the following settings:

- Link Layer Discovery Protocol (LLDP): On
- Multicast Discovery IP: 239.255.255.254
- Multicast Video IP: 239.1.4.6
- Multicast Audio IP: 239.0.4.6
- * USB Multicast IP: 239.2.7.226
- Quality of Service: 128
- Time to Live: 10

At the bottom left, there is a blue button labeled "EDIT" with a circled number 1 (❶) next to it.

* NAV E 501 only

Figure 60. Advanced Networking Selection

The screenshot shows the "Advanced Networking" pane in an editable state. The settings are as follows:

- ❶ **RESET TO DEFAULT** button
- Link Layer Discovery Protocol (LLDP): Off (toggle switch)
- ❷ **Off** / **On** toggle
- ❸ Multicast Discovery IP: 239.255.255.254 (text input)
- ❸ Multicast Video IP: 239.1.7.226 (text input)
- ❸ Multicast Audio IP: 239.0.7.226 (text input)
- ❸ * USB Multicast IP: 239.2.7.226 (text input)
- Quality of Service: 128 (spinners)
- ❹ Range 0-225
- Time to Live: 10 (spinners)
- ❺ Range 1-225
- ❻ **SAVE** and **CANCEL** buttons

* NAV E 501 only



Figure 61. Editable Advanced Networking Selection

- ❶ **Reset to Default** — Click to restore the advanced networking settings of the encoder to their default values.
- ❷ **Link Layer Discovery Protocol (LLDP)** — LLDP, a vendor-neutral protocol, is used by network devices to discovery, identify and share information between two directly connected network devices. Click to toggle **LLDP** on and off.



- ③ **Multicast IP addresses** (see **figure 60** on page 54) — Click in these fields and type in valid IP addresses for your encoder.

NOTES:

- **Multicast Discovery IP** is the multicast IP address that the encoder uses to discover and communicate with all other NAV devices on the network.
- **Multicast Video IP** is the IP address that outputs the NAV video stream.
- **Multicast Audio IP** is the IP address that outputs the NAV audio stream.
- **USB Multicast IP** (NAV E 501 only) is the multicast IP address that the encoder uses to send and receive the USB stream.

- ④ **Quality of Service** — This setting affects the audio and video streams only and accepts valid differentiated services code point (DSCP) type of service (TOS) decimal values to adjust the priority of the packets. Click the  and  buttons or type a number into the field (within the range 0 to 225) to overwrite the factory default.

NOTE: The lower the number, the lower the priority of the packet within a queue. This may result in packet loss, latency, and jitter in a saturated link.

- ⑤ **Time to Live** — Click the  and  buttons or type a number into the field (within the range 1 to 225) to overwrite the factory default.

NOTE: Understanding how many network hops your farthest endpoint is can help assure that the packet reaches the desired destination. If too small of a value is entered, the network could discard the packet before it reaches the destination. In this case, the endpoint does not receive the streams.

- ⑥ **Save and Cancel buttons** — Click **Save** to take changes or **Cancel** to abandon them. Clicking either button closes the editable pane.

About Page

Access the **About** page by clicking **About** (see figure 62, ❶).

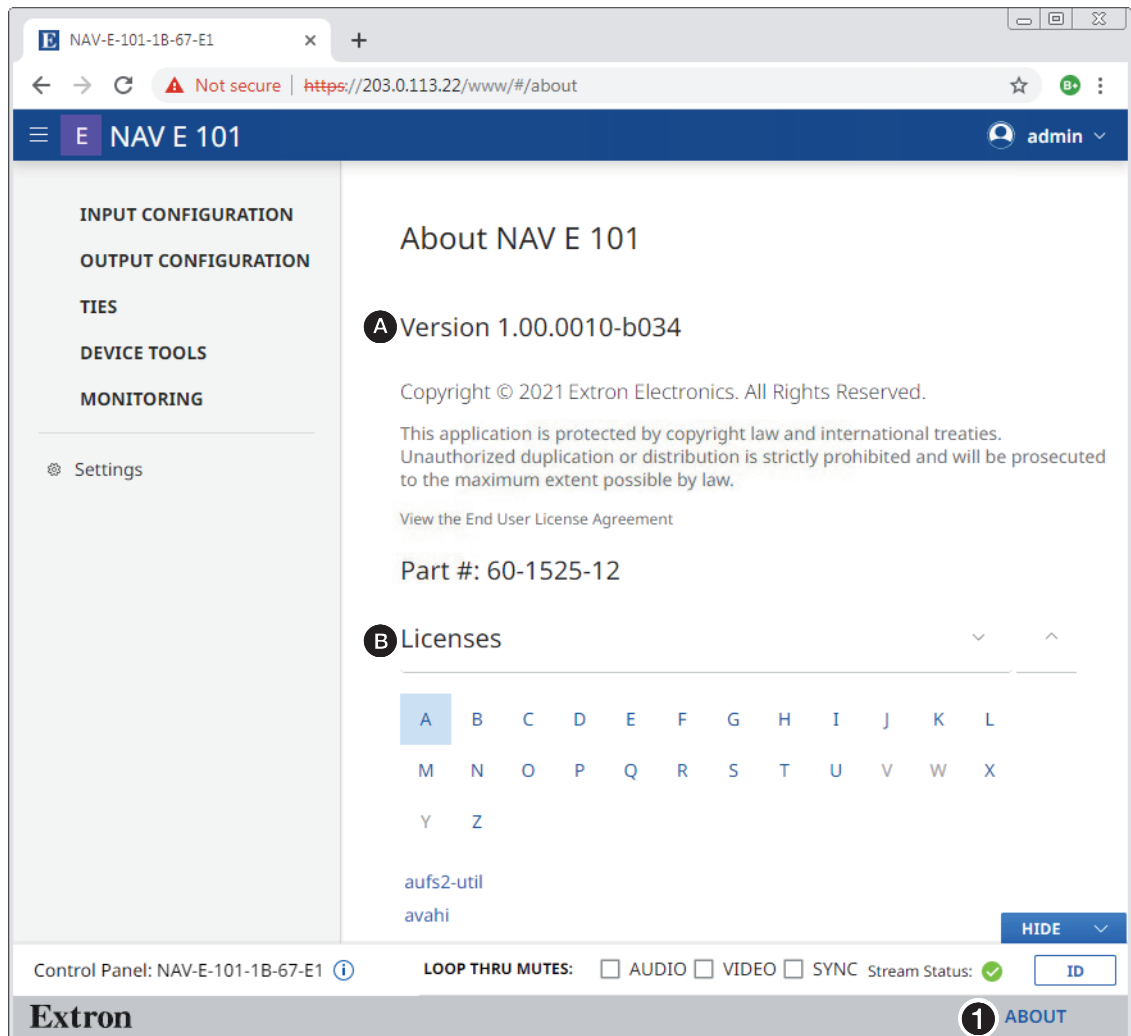

Figure 62. About Pane

The About pane provides the following useful information:

- A** **Firmware version number**, which is current NAV firmware version running.
- B** **Installed licenses**, which can be sorted by click the desired filtering letter.

Control System

This section includes:

- [Secure Platform Device](#)
- [Toolbelt](#)
- [Global Configurator Plus and Professional](#)
- [Global Scripter](#)

The encoder can be remotely controlled from a host device such as a computer or Extron control system. The controlling device communicates over the network via the NAV/PoE+ port (see [item G](#) on page 6).

Secure Platform Device

As a Secure Platform Device (SPD), the encoder is a system based device that communicates with an Extron controller and supports 802.1X port-based Network Access Control. When applied, 802.1X authentication requires that all devices are approved before network access is granted.

The encoder communicates with compatible controllers such as Extron IPCP Pro and IPL Pro series control products over a secure, encrypted channel. The encoder hosts multiple Secure Platform Interfaces, exposing control of the entire NAV system to connected primary controllers.

Toolbelt

The Extron Toolbelt utility is available on the Extron [website](#). Toolbelt is a stand-alone Windows® application for the management of control systems. Toolbelt can automatically discover Pro Series controllers and devices and NAV devices on a network (see the *Toolbelt Help file*). You also can manually add devices, using the known IP addresses. Once you log in to a NAV device, such as a NAVigator or NAV E 101, you can perform tasks such as:

- Launch the embedded encoder HTML page after discovery.
- View the device and system information.
- View and edit network information.
- View and set SSL certifications.
- Use utilities such as **Ping**, **Reset**, and **Reboot**.
- Configure 802.1X security settings.
- View 802.1X status logs.
- Update the firmware to a selected device or group of devices.

Secure Sockets Layer (SSL) Certificates

Extron NAV devices ship with factory-installed SSL certificates created by Extron. If you want or are required to use a different SSL certificate at your installation site, then you can use system utilities in the Toolbelt software to change the SSL certificate at any time. The *Toolbelt Help File* provides instructions on how to apply an SSL certificate to a device.

NOTES:

- You must run Toolbelt as an administrator.
- Some certificates require a passphrase that is created when the certificate is created. If a passphrase is required, you must enter that passphrase before uploading and applying the certificate.

NAV devices support standard OpenSSL certificate encodings such as **.pem** (Privacy-enhanced Electronic Mail) and **.der** (Distinguished Encoding Rules) file types. PEM file types are ASCII encoded and are the required format for uploading to the device. DER file types are binary encoded and can typically have several file extension variations, such as **.crt** and **.cer**. There are many standard tools that can convert from DER to PEM file encodings if needed.

NOTE: A DER format file must be converted to PEM encoding before uploading it to the device.

To properly create the certificate for uploading to Extron NAV devices, ensure that the certificate file meets the following requirements:

- Contains X.509 certificate information
- Contains public and private keys
- Uses PEM encoding

NOTE: ITU-T standard X.509 covers aspects of public key encryption, digital cryptography, certificates, and validation.

Contact your IT administrator for more information on what tools and policies are required to obtain or create the SSL certificate and, if necessary, the corresponding passphrase.

Global Configurator Plus and Professional

NOTE: NAV products can be used in control systems with the following Extron control products:

- **IPCP Pro Processors** such as the IPCP Pro 250
- **IPL Pro Control Processors** such as the IPL Pro S3

Global Configurator is an Extron control system configuration software for use in AV systems that include Extron Pro Series control products. Conditional logic, variables, and macros provide flexibility for elaborate control system designs. No direct programming knowledge is needed to use the program.

The functional logic is built into Global Configurator. You merely select the functions that you want to use. You can quickly set up schedules, macros, monitors, and the like, using available actions and commands, without having to write control script.

Global Configurator has two modes:

- **Global Configurator Plus** — Ideal for smaller applications requiring one control processor and one control interface.
- **Global Configurator Professional** — Suited for applications requiring multiple control processors, enhanced functionality, and advanced configuration. Access to Global Configurator Professional requires ECP Certification.

In a NAV system with an Extron controller, such as an IPCP Pro 250, you can perform actions such as:

- Load device drivers for monitoring the status of and controlling devices with the NAV system.
- Upload GUI Designer interface layouts to touchpanels and third-party touch interfaces.
- Create the configuration containing all the settings for the control processor and the products with which it interacts in the NAV system.
- Upload the configuration to the control processor.
- Send limited commands (such as some SIS commands) via the controller to a NAV device (but without receiving a response from the device).

To obtain Extron control product software, you must have an Extron Insider account and contact an Extron support representative on the Extron S3 Sales and Technical Support Hotline (see [https:// www.extron.com](https://www.extron.com) for the phone number in your region of the world). Extron provides training to our customers on how to use the software. Access to the features of Global Configurator Professional is available to users who successfully complete Extron Control Professional Certification.

For detailed descriptions and procedures to setup a control system with an IPCP Pro device and Global Configurator, see the applicable *Global Configurator Help File*.

Global Scriptor

NOTE: NAV products can be used in control systems with the following Extron control products:

- **IPCP Pro Processors** such as the IPCP Pro 250
- **IPL Pro Control Processors** such as the IPL Pro S3

Global Scriptor is a powerful and versatile control system programming software from Extron for AV systems that use an Extron Pro series control processor (such as an IPCP Pro 250). Global Scriptor, being programming (rather than just configuration) software, is much more flexible than Global Configurator. Global Scriptor allows an integrator to write customized programs for his or her specific AV system. Using customized programming commands for configuration and control allows for larger AV systems than Global Configurator.

Global Scriptor uses the easy-to-learn Python scripting language and includes the Extron-exclusive Python library: ControlScript. ControlScript increases the productivity of AV programmers by incorporating functions used in common AV control system projects, as well as helpful documentation, reference material, and sample code. Global Scriptor can insert specific AV devices (such as SPDs) and functions into the code.

In a NAV system with an Extron controller, such as an IPCP Pro 250, you can support many more devices (system controllers, NAVigators, and endpoints) than Global Configurator, send very specific SIS commands (as programmed code) and get feedback.

NOTE: Global Scriptor software users and integrators other and must know how to program with Python and should know how to use Extron ControlScript.

For detailed descriptions and procedures to setup a control system with an IPCP Pro device and Global Scriptor, see the *Global Scriptor Help File*.

SIS Operation

The encoder can be remotely controlled, monitored, or configured using the following:

- A user-defined string consisting of SIS commands (see below)

NOTE: SIS commands cannot be issued directly to the encoder, but are issued via an Extron control system on the AV network using a process known as “encapsulation”.

- Extron Toolbelt or a control system constructed using either Global Configurator Plus, Global Configurator Pro, or Global Scripter (see **Control System** on page 57)
- Built-in HTML pages (see **HTML Operation** on page 16)

This section provides guidance on operation of the encoder via a string of commands and lists the SIS commands, including:

- **Host-to-Encoder Communications**
- **Encoder-Initiated Messages**
- **Encoder Error Responses**
- **Using the Command and Response Tables**
- **SIS Command and Response Table**

Host-to-Encoder Communications

SIS commands consist of one or more characters per field. No special characters are required to begin or end a command character sequence. When a command is valid, the encoder executes the command and sends a response to the host device. All responses from the encoder to the host end with a carriage return and a line feed (CR/LF = **↵**), which signals the end of the response character string. A string is one or more characters.

Encoder-Initiated Messages

When the encoder completes its start-up, it issues the following message to the host:

© Copyright 20yy, Extron Electronics NAV E n01, Vx.xx, 60-nnnn-nn↵ (n = 5 or 1)
<date> and <time>↵

Vx.xx is the firmware version number and 60-nnnn-nn is the part number.

Hplgl<status>↵

The HDMI input hot plug connection is changed. 1 is plugged and 0 is unplugged.

HplgO<status>↵

The HDMI loop through hot plug connection is changed. 1 is plugged and 0 is unplugged.

In<status>↵

A change in signal input status has occurred. 1 is input detected and 0 is no input.

Encoder Error Responses

When the encoder receives a valid SIS command, it executes the command and sends a response to the host device. If the encoder is unable to execute the command because the command is invalid or it contains invalid parameters, the encoder returns an error response to the host. The error response codes are:

- E10 — Invalid command
- E12 — Invalid port number
- E13 — Invalid parameter
- E14 — Invalid for this port configuration
- E17 — Invalid command for signal type
- E22 — Busy
- E24 — Privilege violation
- E25 — Device not present
- E28 — Bad file name or file not found

The command operation is aborted with no other indication.

Using the Command and Response Tables

The **command and response tables** begin on page 63. Symbols are used throughout the table to represent variables in the command and response fields. Command and response examples are shown throughout the table. The ASCII to HEX conversion table below is for use with the command and response table.

ASCII to Hex Conversion Table															
Space	20	!	21	"	22	#	23	\$	24	%	25	&	26	'	27
(28)	29	*	2A	+	2B	,	2C	-	2D	.	2E	/	2F
0	30	1	31	2	32	3	33	4	34	5	35	6	36	7	37
8	38	9	39	:	3A	;	3B	<	3C	=	3D	>	3E	?	3F
@	40	A	41	B	42	C	43	D	44	E	45	F	46	G	47
H	48	I	49	J	4A	K	4B	L	4C	M	4D	N	4E	O	4F
P	50	Q	51	R	52	S	53	T	54	U	55	V	56	W	57
X	58	Y	59	Z	5A	[5B	\	5C]	5D	^	5E	_	5F
`	60	a	61	b	62	c	63	d	64	e	65	f	66	g	67
h	68	i	69	j	6A	k	6B	l	6C	m	6D	n	6E	o	6F
p	70	q	71	r	72	s	73	t	74	u	75	v	76	w	77
x	78	y	79	z	7A	{	7B		7C	}	7D	~	7E	DEL	7F

Common symbol definitions

- ↵ = Carriage return/line feed
- ← = Carriage return (no line feed)
- | = Pipe (can be used interchangeably with the ← character)
- = space
- Esc** = Escape key
- W = Can be used interchangeably with the **Esc** character

SIS Command and Response Tables

Command and Response Table for Encoder Commands

Command Function	SIS Command (Host to Unit)	Response (Unit to Host)	Additional description																					
HDCP authorized device																								
Set input to HDCP authorized	<code>[Esc]E1HDCP ←</code>	<code>HdcpE1 ←</code>	Default. HDCP Authorized is used to bar an HDCP encrypted source into the HDMI Input.																					
Set input to HDCP not authorized	<code>[Esc]E0HDCP ←</code>	<code>HdcpE0 ←</code>																						
View HDCP authorized status	<code>[Esc]EHDCP ←</code>	<code>[X1] ←</code>																						
Input signal status																								
View input signal status	<code>[Esc]0LS ←</code>	<code>[X1] ←</code>																						
USB mode (NAV E 501 only, valid as USB host or USB device)																								
NOTES: <ul style="list-style-type: none"> You can tie a USB host only to a USB device for proper system operation. If you connect a host such as a PC to an endpoint that is in USB device mode, the endpoint cannot recognize the device. 																								
View encoder USB mode	<code>[Esc]MUSBC ←</code>	<code>[X5] ←</code>																						
USB tie (NAV E 501 only, valid in device mode only)																								
NOTE: If the encoder is in host mode or off, it returns an E14 error in response to the <code>tie</code> , <code>untie</code> , and <code>view tie</code> commands.																								
Tie encoder to USB host	<code>[Esc][X6][X7]^ ←</code>	<code>In[X6][X7]•Usb ←</code>																						
Untie USB	<code>[Esc]0i^ ←</code>	<code>In0i•Usb ←</code>	The untie command is always <code>[Esc]0i^</code> , even for an encoder.																					
View USB tie	<code>^</code>	<code>[X6]i ←</code>																						
USB status (NAV E 501 only)																								
View host status	<code>[Esc]IUSBC ←</code>	<code>UsbcI[X1] ←</code>																						
View device status	<code>[Esc]OUSBC ←</code>	<code>UsbcO[X1] ←</code>																						
Streaming control																								
Set video stream on	<code>[Esc]V1STRC ←</code>	<code>StrcV1 ←</code>	Default.																					
Set video stream off	<code>[Esc]V0STRC ←</code>	<code>StrcV0 ←</code>																						
Set audio stream on	<code>[Esc]A1STRC ←</code>	<code>StrcA1 ←</code>	Default.																					
Set audio stream off	<code>[Esc]A0STRC ←</code>	<code>StrcA0 ←</code>																						
View video stream	<code>[Esc]VSTRC ←</code>	<code>[X1] ←</code>																						
View audio stream	<code>[Esc]ASTRC ←</code>	<code>[X1] ←</code>																						
Streaming bit rate																								
Set streaming rate	<code>[Esc]V[X2]BITR ←</code>	<code>BitrV[X2] ←</code>																						
Show bit depth mode	<code>[Esc]VBITR ←</code>	<code>[X2] ←</code>																						
Video mute (HDMI Loop Thru port)																								
Mute video only	1B	<code>Vmt1 ←</code>																						
Mute video and sync	2B	<code>Vmt2 ←</code>																						
Unmute video and sync	0B	<code>Vmt0 ←</code>	Default. Video output is active.																					
Show mute status	B	<code>[X3] ←</code>																						
KEY: <table border="0" style="width: 100%;"> <tr> <td><code>[X1]</code> = Status</td> <td>0 = Off, disabled, not detected</td> <td>1 = On, enabled, detected</td> </tr> <tr> <td><code>[X2]</code> = Streaming rate or bandwidth (in Mbps)</td> <td>150 — 900 (default = 850)</td> <td></td> </tr> <tr> <td><code>[X3]</code> = Video mute status</td> <td>0 = Unmute</td> <td>1 = Mute video 2 = Mute video and sync</td> </tr> <tr> <td><code>[X4]</code> = Audio routing</td> <td>0 = Auto (default)</td> <td>1 = Digital (HDMI) input 2 = Analog input</td> </tr> <tr> <td><code>[X5]</code> = USB mode</td> <td>0 = Off</td> <td>1 = Host 2 = Device</td> </tr> <tr> <td><code>[X6]</code> = USB host</td> <td colspan="2">I/O Number: <input number> or <output number></td> </tr> <tr> <td><code>[X7]</code> = Encoder (input) or decoder (output)</td> <td colspan="2">Only first letter (i or o) is valid.</td> </tr> </table>				<code>[X1]</code> = Status	0 = Off, disabled, not detected	1 = On, enabled, detected	<code>[X2]</code> = Streaming rate or bandwidth (in Mbps)	150 — 900 (default = 850)		<code>[X3]</code> = Video mute status	0 = Unmute	1 = Mute video 2 = Mute video and sync	<code>[X4]</code> = Audio routing	0 = Auto (default)	1 = Digital (HDMI) input 2 = Analog input	<code>[X5]</code> = USB mode	0 = Off	1 = Host 2 = Device	<code>[X6]</code> = USB host	I/O Number: <input number> or <output number>		<code>[X7]</code> = Encoder (input) or decoder (output)	Only first letter (i or o) is valid.	
<code>[X1]</code> = Status	0 = Off, disabled, not detected	1 = On, enabled, detected																						
<code>[X2]</code> = Streaming rate or bandwidth (in Mbps)	150 — 900 (default = 850)																							
<code>[X3]</code> = Video mute status	0 = Unmute	1 = Mute video 2 = Mute video and sync																						
<code>[X4]</code> = Audio routing	0 = Auto (default)	1 = Digital (HDMI) input 2 = Analog input																						
<code>[X5]</code> = USB mode	0 = Off	1 = Host 2 = Device																						
<code>[X6]</code> = USB host	I/O Number: <input number> or <output number>																							
<code>[X7]</code> = Encoder (input) or decoder (output)	Only first letter (i or o) is valid.																							

Command and Response Table for Encoder SIS Commands (continued)

Command Function	SIS Command (Host to Unit)	Response (Unit to Host)	Additional description
Audio routing selection			
Select digital (HDMI) audio input	<code>[Esc]I1AFMT←</code>	<code>AfmtI1←</code>	
Select analog audio input	<code>[Esc]I2AFMT←</code>	<code>AfmtI2←</code>	
Select auto audio selection	<code>[Esc]I0AFMT←</code>	<code>AfmtI0←</code>	Default. Digital input takes priority.
View input audio selection	<code>[Esc]IAFMT←</code>	<code>[X4]←</code>	
Audio mute (HDMI Loop Thru port)			
Mute audio	<code>1*1Z</code>	<code>Amt1*1←</code>	
Unmute audio	<code>1*0Z</code>	<code>Amt1*0←</code>	Default. Audio output is active.
View audio mute status	<code>1Z</code>	<code>[X1]←</code>	Audio mute status is <code>[X1]</code> .
Reset			
Reset to factory setting	<code>[Esc]ZQQQ←</code>	<code>Zpq←</code>	Reset to factory defaults. Firmware version remains the same.
Device name			
Set device name	<code>[Esc][X8]CN←</code>	<code>Ipn•[X8]←</code>	
Read device name	<code>[Esc]CN←</code>	<code>[X8]←</code>	
Reset device name to factory default	<code>[Esc]•CN←</code>	<code>Ipn•NAV-E-n01-<last 3 pairs of the MAC address>←</code> (n = 5 or 1)	
Device tags			
View device tags	<code>[Esc]DTAG←</code>	<code>[X9]←</code>	
Device number			
View device number	<code>[Esc]DNUM←</code>	<code>[X10]←</code>	
Information requests			
Information request	I	<code>SigI[X1]•HdcpI[X11]•HdcpO[X11]•ResI[X12]•AudI[X13]•StrmI[X14]•Lnk[X14]•Enc←</code>	
<i>Response description:</i>		<i>Input signal•Input HDCP•Output HDCP•Resolution•Input audio•Streaming•Link•Encoder←</i>	
<i>Example:</i>	I	<code>SigI1•HdcpI2•HdcpO2•ResI1920x1080@60 Hz•AudI0•StrmI1•Lnk1•Enc←</code>	An input signal is detected, the input and output are HDCP devices, the resolution is 1920x1080@60 Hz, the digital audio input is selected, streaming and link are active, and the device is an encoder.
View model name	1I	<code>NAV•E•n01←</code>	n = 5 or 1.
View model description	2I	<code>NAV•Gigabit•Encoder•HDMI←</code>	
View number of connected users	10I	<code>[X15]←</code>	
View input video format	34I	<code>[X16]←</code>	
View HDCP input status	35I	<code>[X11]←</code>	
View audio input selection	36I	<code>[X13]←</code>	
View streaming status	37I	<code>[X14]←</code>	
View HDCP output status	38I	<code>[X11]←</code>	
KEY:			
<code>[X1]</code> = Status	0 = Off, disabled, not detected	1 = On, enabled, detected	
<code>[X4]</code> = Audio routing	0 = Auto (default)	1 = Digital (HDMI) input	2 = Analog input
<code>[X8]</code> = Name	A text string of up to 63 alphanumeric characters and minus sign/hyphen (-). No blank or space characters are permitted as part of a name. The first character must be a letter, and the last character must not be a minus sign/hyphen		
<code>[X9]</code> = Tag	A list of text tags returned in a json string		
<code>[X10]</code> = Device number	0001 – 4096		
<code>[X11]</code> = HDCP status	0 = No device	1 = Non-HDCP device	2 = HDCP device
<code>[X12]</code> = Resolution and rate in plain text	<i>Example: 1920x1080@60 Hz</i>		
<code>[X13]</code> = Audio input selected	0 = Digital	1 = Analog	
<code>[X14]</code> = Streaming and link status	0 = No link	1 = Active	2 = Active with errors
<code>[X15]</code> = Number of connected users	0 – 1		
<code>[X16]</code> = Input video format	0 = Not detected	1 = HDMI	2 = DVI

Command and Response Table for Encoder SIS Commands (continued)

Command Function	SIS Command (Host to Unit)	Response (Unit to Host)	Additional description
Information requests, continued			
View connected video streams	39I	<pre> [X17] ← [X17] ← • • ← • • ← [X17] ← ← </pre>	Show all (n) connected video streams.
<i>Example:</i>	39I	<pre> Conf Rm 1, 192.168.254.254, 239.199.188.175 ← Conf Rm 2, 192.168.254.253, 239.199.188.165 ← • • • ← Class Rm 5, 192.168.254.252, 239.199.188.155 ← ← </pre>	
View connected audio streams	40I	<pre> [X17] ← [X17] ← • • ← • • ← [X17] ← ← </pre>	Show all (n) connected audio streams.
View average bandwidth	41I	[X2] ←	
View current total bandwidth	42I	[X2] ←	
View current video bandwidth	43I	[X2] ←	
View current audio bandwidth	44I	[X2] ←	
View network status	46I	[X14] ←	
View dropped packets	48I	[X18] ←	
View IGMP querier	50I	[X19] ←	
View device serial number	98I	[X20] ←	
View internal temperature	[Esc]20STAT ←	[X21] ←	
Firmware version			
Read firmware version	Q	[X22] ←	
Read full firmware version	*Q	[X23] ←	
Read full firmware version — Advanced	20Q	[X24] ←	
Part number			
View part number	N	60-xxxx-xx ←	
KEY: [X2] = Streaming rate or bandwidth (in Mbps) 150 — 900 (default = 850) [X14] = Streaming and link status 0 = No link 1 = Active 2 = Active with errors [X17] = Connected streams <hostname>, <IP address>, <Multicast IP> [X18] = Dropped packets (in percent) 00 — 100 [X19] = IP address xxx.xxx.xxx.xxx [X20] = Serial number [X21] = Internal temperature xxxF•xxC [X22] = Firmware version x.xx [X23] = Full firmware version x.xx.xxxx [X24] = Full firmware version — advanced x.xx.xxxx-bnnn			

Troubleshooting

Alarms

The following table lists common NAV alarms shown on the **Monitoring** page (see **Alarms pane** on page 43) and suggested remedies:

Alarm	Cause	Remedy
Assignment Conflict	The endpoint is reporting a conflicting assignment status.	Verify that the endpoint is not assigned to another NAVigator. If it is, it must be unassigned from the previous NAVigator. If the previous NAVigator is unavailable, perform a mode 5 reset (see page 14) on the conflicted endpoint.
Assignment Failure	The endpoint failed to be assigned to a NAVigator.	Confirm that the NAVigator has not reached its endpoint assignment limit. If a device has been decommissioned from the NAV system, unassign the endpoint from the "Offline endpoints" list. If endpoint still cannot be assigned, perform a mode 5 reset on the endpoint.
Audio Loss	The input audio signal level is below -60 dB for a period of 5 minutes or more.	Increase the output level of audio source.
Auth Failures	A user has attempted to login unsuccessfully 10 or more times.	Check whether login attempts were from internal personnel. If not, take action to strengthen security measures.
Backup Restore Failure	A problem occurred while trying to perform a backup or a restore.	Debug network connectivity between the NAVigator and endpoints.
Channel Conflict	Two or more NAV devices on the network have been given the same input or output number.	For devices affected, change the input number or output number so that each is unique in the system.
Communication Failure	An online assigned endpoint cannot establish a connection with the NAVigator.	Check the network settings to ensure unicast routing is possible between the NAVigator and endpoints.
Controller Disconnect	The NAV device is unable to connect to a paired control processor.	Verify the control processor is online. Review network settings to ensure unicast communication is possible from the NAV device to the control processor.
CPU Usage	The NAV device CPU is overloaded.	Check for excessive network data being delivered to the endpoint.
Device Offline	An assigned NAVigator is not discovered on the network.	Check the offline NAVigator for a power failure. Check the network connectivity of the endpoint.

Alarm	Cause	Remedy
Disk Space	Internal storage on the NAV device is low.	Reboot the NAV device. If the issue persists, perform a software reset that delete files (see Reset tab on page 37).
Firmware Failure	A critical process has failed, crashing the endpoint.	Reboot the NAV device. If the failure persists, perform a mode 1 reset (see Reset Operations on page 14) .
Firmware Incompatible	A firmware version discrepancy exists between the NAVigator and assigned endpoints.	Upgrade the firmware on the deviating device.
Firmware Upgrade	The firmware upgrade process on NAVigator or endpoints failed to complete.	Retry the firmware upgrade. If it is again unsuccessful, use Toolbelt or a web browser to directly manage the device and perform a unit firmware upgrade.
HDCP Error	<p>Encoder: The video input signal is HDCP protected and HDCP negotiation has failed.</p> <p>Decoder: The incoming stream is HDCP protected and the display connected to the output does not support HDCP or the HDCP version.</p>	<p>Encoder:</p> <ul style="list-style-type: none"> • Disconnect and reconnect the video input cable into the encoder. • Bypass video adapter cables and make a direct HDMI male-to-male connection. <p>Decoder: Check the technical specifications of the display that is connected to the decoder for HDCP version support.</p>
IGMP Failure	The NAV device failed to receive three consecutive IGMP queries from an IGMP querier.	Debug network connectivity between the NAV device and the IGMP querier (which can be either a router or a managed switch).
Link Speed	The negotiated communication speed (Link Speed) between the NAV device and a managed switch is lower than its capability of 1 Gbps.	Check switch configuration and ensure proper settings for the switch port to which the NAV device is connected.
Name Conflict	Two or more NAV devices on the network have the same device name.	Change the device names affected so that each is unique.
Network Conflict	Two or more NAV devices on the network have the same IP address.	Change the IP addresses affected so that each is unique.
Network Utilization	The NAV device is receiving excessive network traffic.	Check the network for flooding, also check for improper network configuration.
NTP Sync	The NAVigator cannot obtain time from the specified NTP server.	Debug the network connectivity between the NAVigator and the specified NTP server.
PTP Master Stability	The clock to which all devices are synchronized is changing too frequently, for example, due to network jitter.	Check network for flooding and correct PTPv2 packet priority.
PTP Sync	NAV device cannot synchronize its PTPv2 clock with any peers.	Ensure that network policies allow PTPv2 packets to reach the NAV Device from a clock master.

Alarm	Cause	Remedy
Stream Conflict	Multiple NAV endpoints are configured to use the same video, audio, AES67, or USB multicast IP address.	Reconfigure endpoint stream settings for a unique stream address.
Stream error	NAV E 501 only — The encoder has lost reception of the USB stream for 2 seconds or more.	Check all network switches and routers that support your NAV system for proper multicast (IGMP) configuration.
Temperature Internal	The NAV device is overheating.	<p>Check the ambient temperature of the NAV device installation location.</p> <ul style="list-style-type: none"> • If greater than 104 °F, (60 °C) use HVAC system to lower ambient temperature. • If ambient temperature is 104 °F, (60 °C) or less, check the mounting location for nearby equipment emitting excessive heat. Ensure there is an air gap around endpoint to allow adequate airflow.
Tie Failure	The encoder failed to establish a tie with the specified endpoint.	Debug the network connectivity between the encoder and decoder.
Video loss	The input is changed and video sync cannot be established within a two-second window.	Debug the connectivity of the A/V source device to the NAV encoder.

Reference Information

Mounting the Encoder

ATTENTION:

- Installation and service must be performed by authorized personnel only.
- L'installation et l'entretien doivent être effectués par le personnel autorisé uniquement.

The 1-inch high, half-rack width encoder can be placed on a table, mounted in a rack, or mounted under a desk or table.

Tabletop Use

Affix the included rubber feet to the bottom of the unit and place it in any convenient location.

Mounting kits

Mount the unit using any optional compatible mounting kit listed on the Extron website (<https://www.extron.com>), in accordance with the directions included with the kit.

ATTENTION:

- When mounting the encoder under furniture, mount the device upside-down to ensure proper ventilation.
- Si vous installez le encoder sous un mobilier, veillez à installer l'unité à l'envers pour assurer une bonne ventilation.

For rack mounting, see "UL Rack-Mounting Guidelines," below.

UL Rack-Mounting Guidelines

The following Underwriters Laboratories (UL) requirements pertain to the installation of the unit into a rack.

CAUTION:

- **Elevated operating ambient temperature** — If installed in a closed or multi-unit rack assembly, the operating ambient temperature of the rack environment may be greater than room ambient. Therefore, consider installing the equipment in an environment compatible with the maximum ambient temperature (TMA = +104 °F, +40 °C) specified by Extron.
- **Reduced air flow** — Installation of the equipment in a rack should be such that the amount of air flow required for safe operation of the equipment is not compromised.
- **Mechanical loading** — Mounting of the equipment in the rack should be such that a hazardous condition is not achieved due to uneven mechanical loading.
- **Circuit overloading** — Consideration should be given to the connection of the equipment to the supply circuit and the effect that overloading of the circuits might have on overcurrent protection and supply wiring. Appropriate consideration of equipment nameplate ratings should be used when addressing this concern.
- **Reliable earthing (grounding)** — Reliable earthing of rack-mounted equipment should be maintained. Particular attention should be given to supply connections other than direct connections to the branch circuit (such as use of power strips).

Consignes UL pour le montage en rack

Les consignes UL (« Underwriters Laboratories ») suivantes concernent l'installation en rack d'un boîtier l'encodeur :

ATTENTION :

- **Température ambiante élevée** — En cas d'installation de l'équipement dans un rack fermé ou composé de plusieurs unités, la température du rack peut être supérieure à la température ambiante. Par conséquent, il est préférable d'installer l'équipement dans un environnement qui respecte la température ambiante maximale (Tma) spécifiée par Extron.
- **Réduction du flux d'air** — Si l'équipement est installé dans un rack, veillez à ce que le flux d'air nécessaire pour un fonctionnement sécurisé de l'équipement soit respecté.
- **Charge mécanique** — Installez l'équipement en rack de manière à éviter toute situation dangereuse causée par le déséquilibre de la charge mécanique.
- **Surcharge électrique** — Lorsque vous connectez l'équipement au circuit d'alimentation, observez la connexion de l'équipement et étudiez les effets possibles d'une surcharge du circuit sur les protections contre les surintensités et les conducteurs d'alimentation. Consultez à cet égard les indications de la plaque d'identification de l'équipement.
- **Mise à la terre** — Assurez-vous que l'équipement est correctement mis à la terre. Accordez une attention particulière aux connexions électriques autres

Extron Warranty

Extron warrants this product against defects in materials and workmanship for a period of three years from the date of purchase. In the event of malfunction during the warranty period attributable directly to faulty workmanship and/or materials, Extron will, at its option, repair or replace said products or components, to whatever extent it shall deem necessary to restore said product to proper operating condition, provided that it is returned within the warranty period, with proof of purchase and description of malfunction to:

USA, Canada, South America, and Central America:

Extron
1230 South Lewis Street
Anaheim, CA 92805
U.S.A.

Asia:

Extron Asia Pte Ltd
135 Joo Seng Road, #04-01
PM Industrial Bldg.
Singapore 368363
Singapore

Japan:

Extron Japan
Kyodo Building, 16 Ichibancho
Chiyoda-ku, Tokyo 102-0082
Japan

Europe:

Extron Europe
Hanzeboulevard 10
3825 PH Amersfoort
The Netherlands

China:

Extron China
686 Ronghua Road
Songjiang District
Shanghai 201611
China

Middle East:

Extron Middle East
Dubai Airport Free Zone
F13, PO Box 293666
United Arab Emirates, Dubai

Africa:

Extron South Africa
3rd Floor, South Tower
160 Jan Smuts Avenue
Rosebank 2196, South Africa

This Limited Warranty does not apply if the fault has been caused by misuse, improper handling care, electrical or mechanical abuse, abnormal operating conditions, or if modifications were made to the product that were not authorized by Extron.

NOTE: If a product is defective, please call Extron and ask for an Application Engineer to receive an RA (Return Authorization) number. This will begin the repair process.

USA: 714.491.1500 or 800.633.9876

Asia: 65.6383.4400

Europe: 31.33.453.4040 or 800.3987.6673

Japan: 81.3.3511.7655

Africa: 27.11.447.6162

Middle East: 971.4.299.1800

Units must be returned insured, with shipping charges prepaid. If not insured, you assume the risk of loss or damage during shipment. Returned units must include the serial number and a description of the problem, as well as the name of the person to contact in case there are any questions.

Extron makes no further warranties either expressed or implied with respect to the product and its quality, performance, merchantability, or fitness for any particular use. In no event will Extron be liable for direct, indirect, or consequential damages resulting from any defect in this product even if Extron has been advised of such damage.

Please note that laws vary from state to state and country to country, and that some provisions of this warranty may not apply to you.