



**Fuze Pendant**

**Emergency Power**

Photometric Test Report

©2020 ELATION PROFESSIONAL all rights reserved. Information, specifications, diagrams, images, and instructions herein are subject to change without notice. ELATION PROFESSIONAL logo and identifying product names and numbers herein are trademarks of ELATION PROFESSIONAL. Copyright protection claimed includes all forms and matters of copyrightable materials and information now allowed by statutory or judicial law or hereinafter granted. Product names used in this document may be trademarks or registered trademarks of their respective companies and are hereby acknowledged. All non-ELATION brands and product names are trademarks or registered trademarks of their respective companies.

**Elation Professional USA** | 6122 S. Eastern Ave. | Los Angeles, CA. 90040

323-582-3322 | 323-832-9142 fax | [www.elationlighting.com](http://www.elationlighting.com) | [info@elationlighting.com](mailto:info@elationlighting.com)

**Elation Professional B.V.** | Junostraat 2 | 6468 EW Kerkrade, The Netherlands

+31 45 546 85 66 | +31 45 546 85 96 fax | [www.elationlighting.eu](http://www.elationlighting.eu) | [info@elationlighting.eu](mailto:info@elationlighting.eu)

**Elation Professional Mexico** | AV Santa Ana 30 | Parque Industrial Lerma, Lerma, Mexico 52000

+52 (728) 282-7070

# CONTENTS

Testing Process	4
25°	5
40°	6
45° (factory installed)	7
50°	8

## Emergency Power Test

For this test the fixture is connected to a 25-48V LED Emergency Driver, providing 15W of power. The Fuze Pendant operates with reduced LED power to provide light output exceeding 90 minutes.

DMX control and display access are not available, and the color temperature is preset for optimum power usage. Light levels and color temperature are not adjustable for Emergency Power Operation.

# Testing Process

## Total Lumen Measurements

Lumens are measured using a Viso Systems Lab Spion. As a goniophotometer, the Viso calculates the field lumens of the fixture by taking multiple measurements across the light beam.

Many lumens figures provided for entertainment lighting fixtures are only  $2\pi$  sphere values, some even emphasize the LED engine lumens. All Elation product photometric data is the actual light output from the fixture lens, never a theoretical value based on calculation or using the source lumens as the fixtures output. We advise to always compare total fixture lumens acquired with identical measurement systems when comparing lighting fixtures.

## Test Lab Equipment and Process

Elation operates an optical testing laboratory at its Los Angeles, CA headquarters to provide accurate photometric data for its lighting products. The testing lab is both light and climate-controlled and contains a variety of precise lighting measurement systems. Fixtures are analyzed with the sophisticated [Viso Systems Lab Spion](#) equipment, which measures all light and color parameters by panning the light beam at a precise speed and from different angles through a calibrated, laser aligned light and color sensor. Test data is collected and summarized by the Viso Light Inspector software. This type of measurement system is referred to as a Goniophotometer.

The Viso software calculates all relevant types of measurements, from beam angles, candela to center light intensity at a variety of distances to the latest color quality measurements like TM30 or CQS as well as accurate color temperature. This wealth of data is then processed by an Elation specific template which is included in the photometric test report for various fixture conditions such as zoom angles and color correction filters.

The Viso software also creates IES (Illuminating Engineering Society) files for each test report. IES is an industry standard file format created for the easy electronic transfer of photometric test data, which is widely used by lighting manufacturers for photometric data distribution.

Additionally, fixtures are periodically rechecked for accuracy using various hand-held light meters including one or more of the devices listed below. This is done to ensure the test data contained in this report is as accurate as possible.

[Asenstek Lighting Passport](#) | [Konica Minolta T-10](#) | [Sekonic C700T](#)

**Total Lumen Output: 2443 lm**

**Voltage: 37.2 V, Current: 0.500 A**

**Power: 18.6 W**

**Efficacy: 131 Lumen/Watt**

**Measurement Date: 9/23/2020**

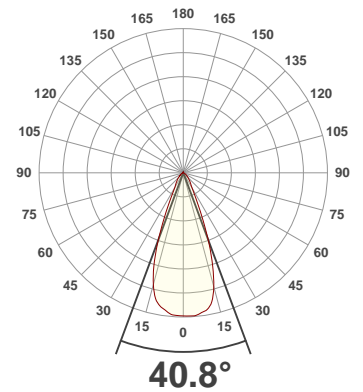
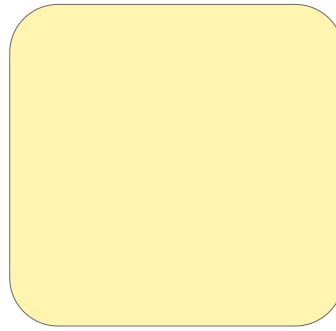

### Spectral distribution

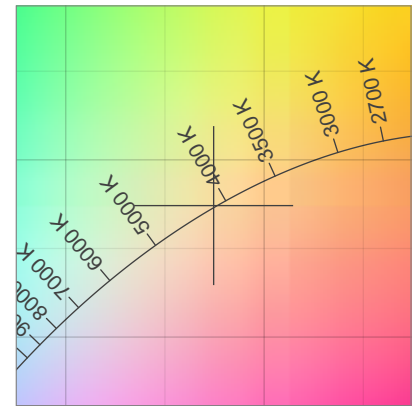
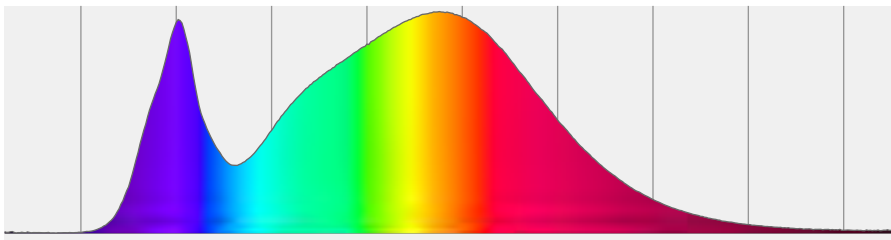

Dominant Wavelength	Color coordinate cie 1931	Color coordinate cie 1931	Color coordinate	Color coordinate
nm	x	y	u	v
581	0.375	0.374	0.222	0.333

### Beam details

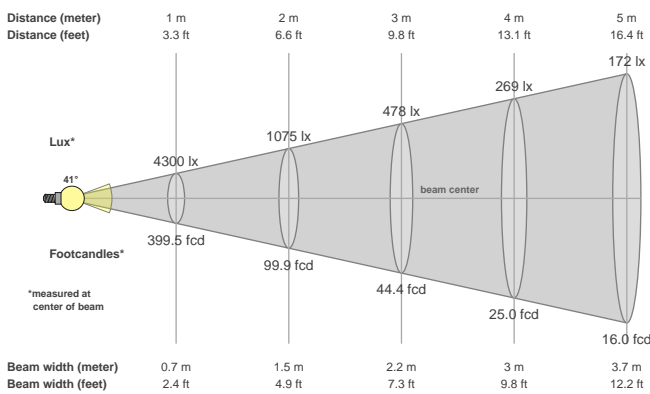

### Beam angles

Beam angle 50%	Field angle 10%	Cutoff angle 2,5%
40.8°	65.4°	108°

### Beam intensities

Peak intensity	Int. ratio in 120° cone	Int. ratio in 90° cone
4305 cd	95.5%	89.0%

### Beam Intensities from 1-20m

M	1	2	3	4	5	6	7	8	9	10	11	12	13	14	15	16	17	18	19	20
FT	3.3	6.6	9.8	13.1	16.4	19.7	23	26.2	29.5	32.8	36.1	39.4	42.7	45.9	49.2	52.5	55.8	59.1	62.3	65.6
LX	4300	1075	478	269	172	119	88	67	53	43	36	30	25	22	19	17	15	13	12	11
FC	399.5	99.9	44.4	25	16	11.1	8.2	6.2	4.9	4	3.3	2.8	2.4	2	1.8	1.6	1.4	1.2	1.1	1

**Total Lumen Output: 2453 lm**

**Voltage: 37.1 V, Current: 0.500 A**

**Power: 18.6 W**

**Efficacy: 132 Lumen/Watt**

**Measurement Date: 9/23/2020**

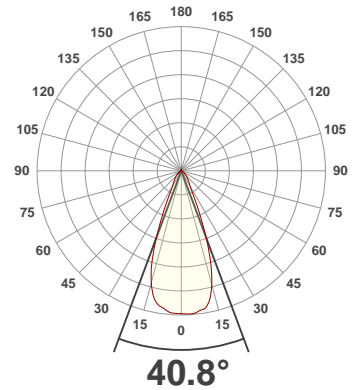
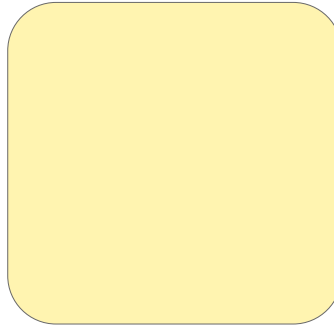

### Spectral distribution

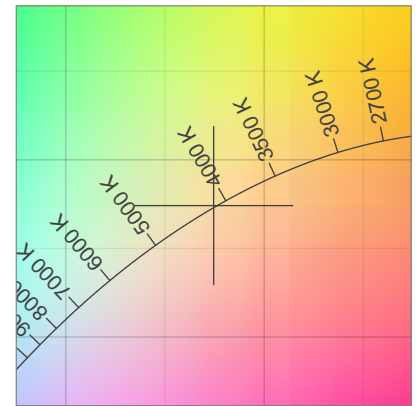
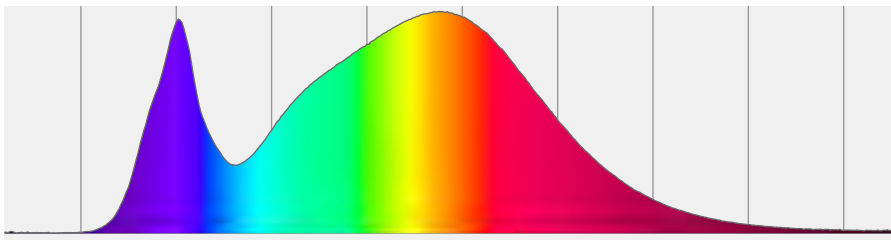

Dominant Wavelength	Color coordinate cie 1931	Color coordinate cie 1931	Color coordinate	Color coordinate
nm	x	y	u	v
581	0.375	0.374	0.222	0.333

### Beam details

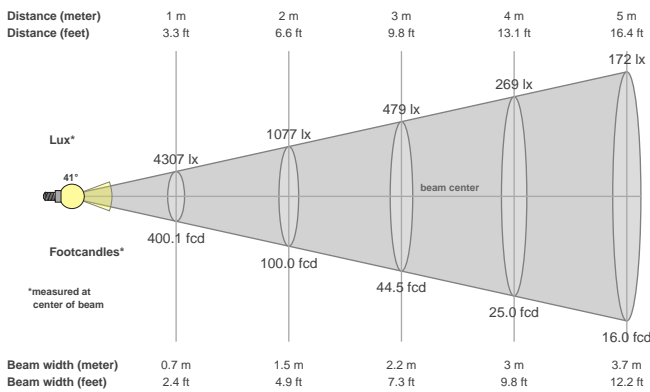

### Beam angles

Beam angle 50%	Field angle 10%	Cutoff angle 2,5%
40.8°	65.8°	108.5°

### Beam intensities

Peak intensity	Int. ratio in 120° cone	Int. ratio in 90° cone
4320 cd	95.5%	89.0%

### Beam Intensities from 1-20m

M	1	2	3	4	5	6	7	8	9	10	11	12	13	14	15	16	17	18	19	20
FT	3.3	6.6	9.8	13.1	16.4	19.7	23	26.2	29.5	32.8	36.1	39.4	42.7	45.9	49.2	52.5	55.8	59.1	62.3	65.6
LX	4307	1077	479	269	172	120	88	67	53	43	36	30	25	22	19	17	15	13	12	11
FC	400.1	100	44.5	25	16	11.1	8.2	6.3	4.9	4	3.3	2.8	2.4	2	1.8	1.6	1.4	1.2	1.1	1

**Total Lumen Output: 2484 lm**

**Voltage: 37.2 V, Current: 0.500 A**

**Power: 18.6 W**

**Efficacy: 134 Lumen/Watt**

**Measurement Date: 9/28/2020**

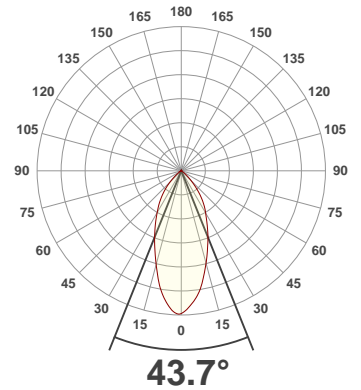
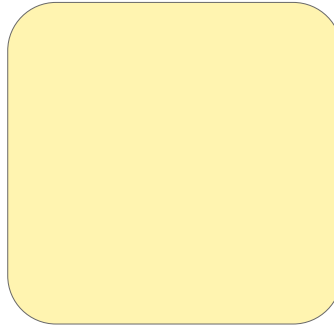

### Spectral distribution

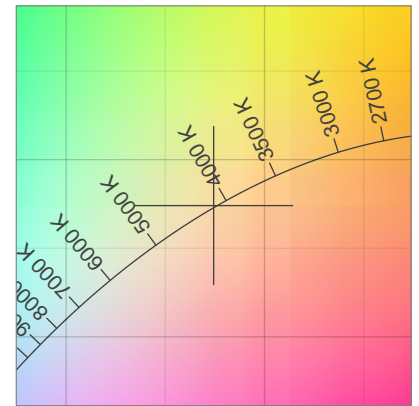
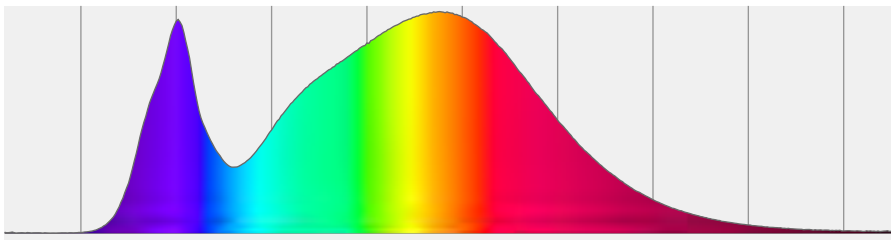

Dominant Wavelength	Color coordinate cie 1931	Color coordinate cie 1931	Color coordinate	Color coordinate
nm	x	y	u	v
581	0.374	0.374	0.222	0.333

### Beam details

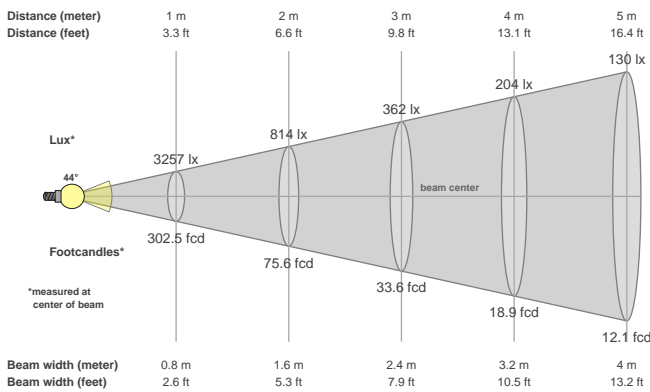

### Beam angles

Beam angle 50%	Field angle 10%	Cutoff angle 2,5%
43.7°	90.7°	107.3°

### Beam intensities

Peak intensity	Int. ratio in 120° cone	Int. ratio in 90° cone
3281 cd	97.1%	90.5%

### Beam Intensities from 1-20m

M	1	2	3	4	5	6	7	8	9	10	11	12	13	14	15	16	17	18	19	20
FT	3.3	6.6	9.8	13.1	16.4	19.7	23	26.2	29.5	32.8	36.1	39.4	42.7	45.9	49.2	52.5	55.8	59.1	62.3	65.6
LX	3257	814	362	204	130	90	66	51	40	33	27	23	19	17	14	13	11	10	9	8
FC	302.5	75.6	33.6	18.9	12.1	8.4	6.2	4.7	3.7	3	2.5	2.1	1.8	1.5	1.3	1.2	1	0.9	0.8	0.8

**Total Lumen Output: 2518 lm**

**Voltage: 37.2 V, Current: 0.500 A**

**Power: 18.6 W**

**Efficacy: 135 Lumen/Watt**

**Measurement Date: 9/23/2020**

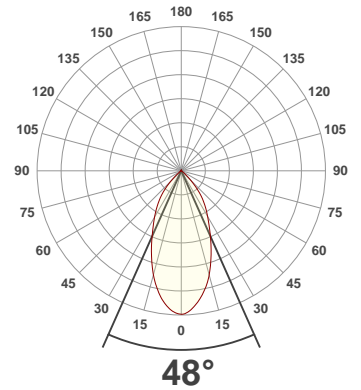
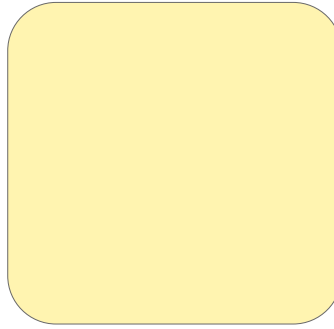

### Spectral distribution

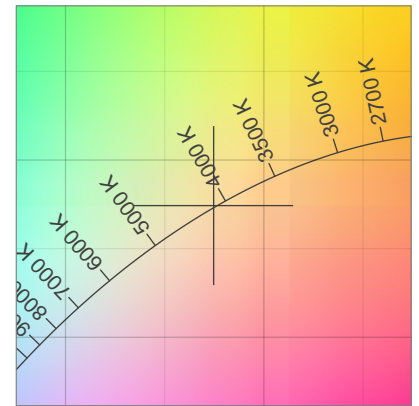
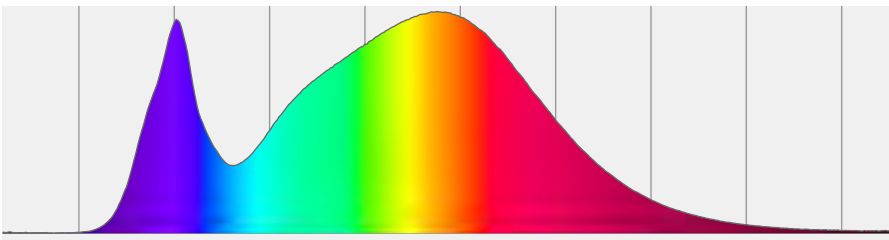

Dominant Wavelength	Color coordinate cie 1931	Color coordinate cie 1931	Color coordinate	Color coordinate
nm	x	y	u	v
581	0.375	0.374	0.222	0.333

### Beam details

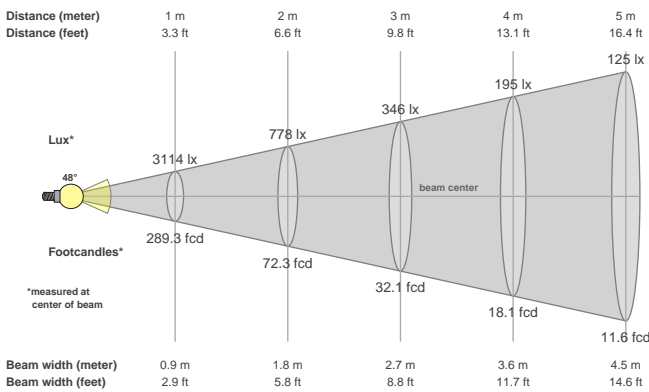

### Beam angles

Beam angle 50%	Field angle 10%	Cutoff angle 2,5%
48°	90.1°	102.4°

### Beam intensities

Peak intensity	Int. ratio in 120° cone	Int. ratio in 90° cone
3118 cd	97.0%	92.3%

### Beam Intensities from 1-20m

M	1	2	3	4	5	6	7	8	9	10	11	12	13	14	15	16	17	18	19	20
FT	3.3	6.6	9.8	13.1	16.4	19.7	23	26.2	29.5	32.8	36.1	39.4	42.7	45.9	49.2	52.5	55.8	59.1	62.3	65.6
LX	3114	778	346	195	125	86	64	49	38	31	26	22	18	16	14	12	11	10	9	8
FC	289.3	72.3	32.1	18.1	11.6	8	5.9	4.5	3.6	2.9	2.4	2	1.7	1.5	1.3	1.1	1	0.9	0.8	0.7