

NAV SD 501 and NAV SD 101 • Setup Guide

This guide provides instructions for an experienced installer to install the Extron NAV SD 501 and NAV SD 101 scaling decoders and to make all connections. One or more compatible Extron NAV encoders and one or more decoders form an AV distribution and switching matrix on a managed 1G IP network.

IMPORTANT:
Go to www.extron.com for the complete user guide, installation instructions, and specifications before connecting the product to the power source.

NOTE: For more information on any subject in this guide, see the *NAV SD 501 and NAV SD 101 User Guide*, available at www.extron.com.

Installation

Step 1 – Mounting

Turn off or disconnect all equipment power sources and rack or furniture mount the decoder as required.

Step 2 – Rear Panel Connections

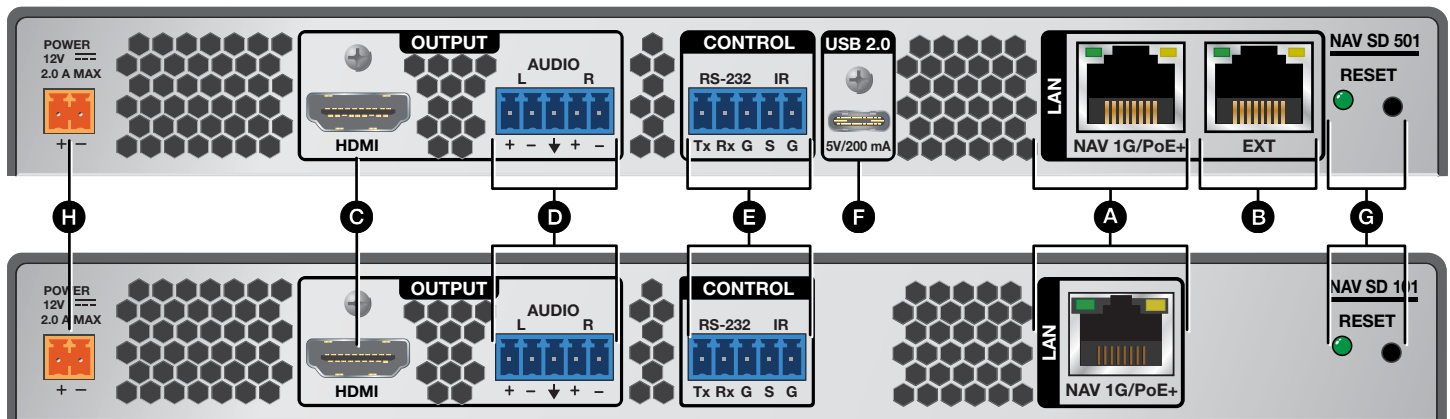

Figure 1. NAV SD 501 and NAV SD 101 Rear Panel Features

- A** **NAV 1G/PoE+ port** — Connect to an Ethernet LAN on which one or more encoders also reside for streaming and control. This port can also receive Power over Ethernet (PoE+) to power the decoder (see **Power** on page 3 for power options).
- B** **Extension port (NAV SD 501 only)** — If desired, connect another networked device to this port. The port acts as a networked switch to the NAV 1G/PoE+ port.

NOTE: The Extension port cannot provide PoE.

- C** **HDMI output port** — Connect an HDMI cable between this port and an HDMI display (or a DVI display, with an appropriate adapter). See **LockIt® Lacing Brackets** on page 6 to use the LockIt HDMI Cable Lacing Bracket to secure the connector to the decoder.
- D** **AUDIO output port** — This 5-pole, 3.5 mm captive screw connector outputs the streamed, unamplified, line level analog audio. Connect an audio device, such as an audio amplifier or powered speakers (see **Analog audio output** on page 6 to wire the connector).
- E** **CONTROL RS-232/IR port** — Connect a serial RS-232 signal, a modulated IR signal, or both to this 3.5 mm, 5-pole captive screw connector for bidirectional RS-232 and IR communication with connected remote controlled devices using an Extron control system (see **Control connector** on page 6 to wire the connector).
- F** **USB 2.0 port (NAV SD 501 only)** — Connect a USB Type-C cable to USB host or a USB device. See **LockIt® Lacing Brackets** to securely fasten the USB connector to the decoder.

NOTE: This connector is limited to supplying 200 mA in USB device mode.

- G** **RESET button** — This button initiates three modes of reset (see the *NAV SD 501 and NAV SD 101 User Guide*, available at www.extron.com, for details).
- H** **POWER connector (optional)** — Plug the included external 12 VDC power supply into this 2-pole connector for local power (see **Power connector** on page 6 to wire the connector and **Power** for power options).

NAV SD 501 and NAV SD 101 • Setup Guide (Continued)

Step 3 – Front Panel Configuration Port Connection

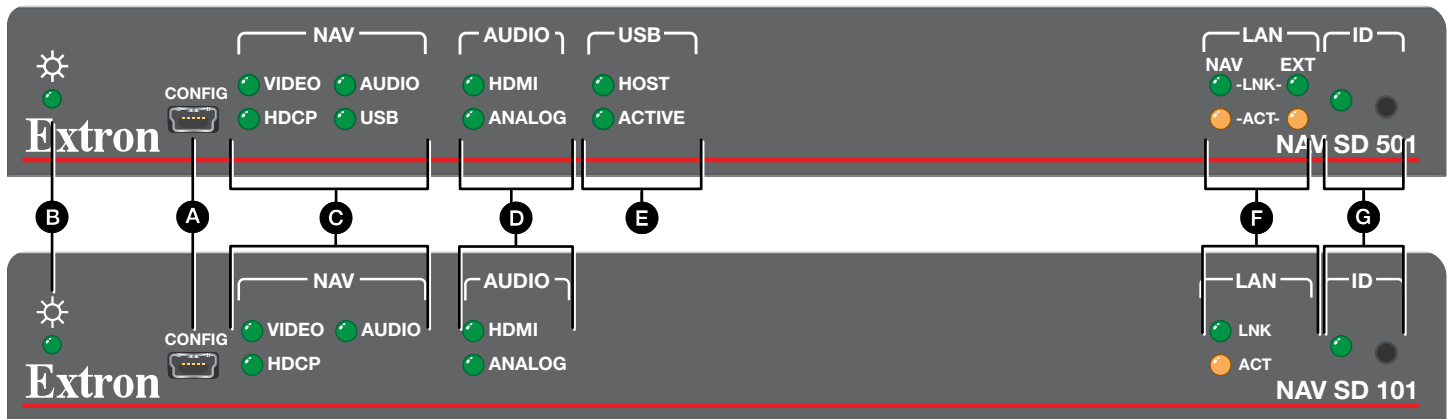

Figure 2. NAV SD 501 and NAV SD 101 Front Panel Features

A Configuration port — Connect a PC to the decoder via this front panel USB Mini-B connector for configuration of the decoder. The port uses IP over USB technology; the IP address is always 203.0.113.22 and **CANNOT** be changed. The Config port is also discoverable via Extron Toolbelt (see the *NAV SD 501 and NAV SD 101 User Guide*; the guide and Toolbelt are available for download at www.extron.com).

Indicators

- B Power LED** — Indicates power and startup status, as follows:
- **Blinking** — The unit is receiving power, either locally or remotely (via PoE) and is booting up.
 - **Lit steadily** — The unit is receiving power, either locally or remotely (via PoE) and is operational.
- C NAV LEDs** — Indicates status of the streaming input, as follows:
- **VIDEO** — Indicates status of the video stream.
 - **Lit steadily** — The decoder is receiving a video stream.
 - **Blinking** — A video stream is being decoded, but network errors are present that affect the video quality.
 - **HDCP** — The video stream is HDCP encrypted.
 - **AUDIO LED** — Indicates status of the audio stream.
 - **Lit steadily** — The decoder is receiving an audio stream.
 - **Blinking** — An audio stream is being decoded, but network errors are present that affect the audio quality.
 - **USB LED (NAV SD 501 only)** — Indicates status of the USB stream.
 - **Lit Steadily** - The decoder is actively receiving and sending a NAV USB stream
 - **Unlit** — The decoder is unable to establish a NAV USB stream.
 - **Blinking** - The decoder is not actively sending and receiving a NAV USB Stream.
- D Audio LEDs** — Indicate the active audio output, as follows:
- **HDMI** — The embedded HDMI audio output is selected.
 - **ANALOG** — The analog audio output is selected.
- E USB LEDs (NAV SD 501 only)** — Indicates the status of the USB stream, as follows:
- **Host**
 - **Lit steadily** — The decoder is in USB host mode.
 - **Unlit** — The decoder is in USB device mode, the default condition.
 - **Active**
 - **Lit steadily** — A USB device or host is connected to the rear panel USB port.
 - **Unlit** — No host or USB device is connected to the rear panel USB port.
 - **Blinking** — A USB device or hub is connected to the decoder and is attempting to draw more power than the USB port can supply.

- F **LAN LEDs** (see [figure 2](#) on page 2)— Indicate the status of the network connections, as follows:
 - **NAV LED** (NAV SD 501) or **LAN LED** (NAV SD 101) —
 - **Link LED** — Lit steadily indicates that a network link is established. Blinking indicates a link speed less than 1G.
 - **Act LED** — Blinking indicates network traffic. The blink rate corresponds to activity.
 - **Ext LED** (NAV SD 501 only) —
 - **Link LED** — Lit steadily indicates that a network link is established. Blinking indicates a link speed less than 100 Mbps.
 - **Act LED** — Blinking indicates network traffic. The blink rate corresponds to activity.
- G **ID button and LED** — The recessed ID button identifies the decoder when pressed. The LED blinks three times when the decoder is paired to a NAV encoder (see [Pairing devices via front panel](#) on page 5).

Operation

Power

The decoder can be powered in one of three ways:

- Locally, from the included external power supply and via the power connector (see [figure 1, H](#) on page 1).
- Remotely, receiving PoE via the NAV 1G/PoE+ port (see [A](#)); either from the network switch or from an optional PI 140 Power Injector.
- Locally ([H](#)) and remotely ([A](#)), with priority on the NAV 1G/PoE+ port. If PoE voltage drops below a threshold, the decoder immediately transitions to the external power supply with no effect on system operation.

When power is applied, the decoder runs a series of self-tests that blink the front panel Power LED and all other indicators. The decoder then boots the NAV operating system. It can take approximately 45 seconds for self-test and system startup to complete. When the process is complete, the Power LED lights steadily.

NOTE: The decoder is **NOT** operational until the boot process is complete (the Power LED is lit steadily).

System Operation

The decoder can be configured and controlled using embedded web pages or Extron Toolbelt (see the *NAV SD 501 and NAV SD 101 User Guide* available at www.extron.com).

NOTE: The “Connection via web pages,” [Connection settings](#), and [Pairing devices via front panel](#) procedures (see page 5) may **NOT** be necessary if your system includes a NAVigator System Manager.

Connection via web pages

Connection to the decoder and its embedded web pages can be made via either the front panel Configuration (USB) port (using IP over USB) (see [figure 2, A](#)) or the rear panel NAV 1G/PoE+ port (see [figure 1, A](#)).

Access the decoder using HTML pages as follows:

1. Start a web browser.

NOTES:

- Suggested browsers to fully support the NAV system are: Google Chrome™, Mozilla™ Firefox™, and Microsoft Edge™.
- The network must be properly configured for multicasting (IGMP). Failure to do so may result in degraded performance.

2. Enter the IP address of the decoder in the browser Address field.

NOTE:

- **Default settings:**

Port	DHCP	IP address	Subnet mask
Config (USB)*		203.0.113.22	
NAV/PoE+ (RJ-45)	On		

* **For the Config port**, the address for IP over USB **CANNOT** be changed.

- If you use IP over USB, Extron recommends waiting a minute after plugging in the cable for your PC to identify the USB connection as a valid Ethernet port

NAV SD 501 and NAV SD 101 • Setup Guide (Continued)

3. Press the keyboard <Enter> key. The browser displays a privacy error message (see figure 3 at right for an example in the Chrome browser).
4. Click **Advanced** (see figure 3, ❶). The button changes to **Hide Advanced** and explanatory text and a link appear below the button.
5. Click **Proceed to <IP address> (unsafe)** (❷). The browser opens to the Login dialog box (see figure 4).

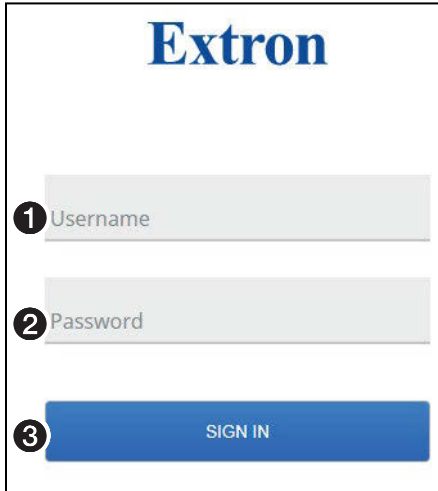

Figure 4. Login Dialog Box

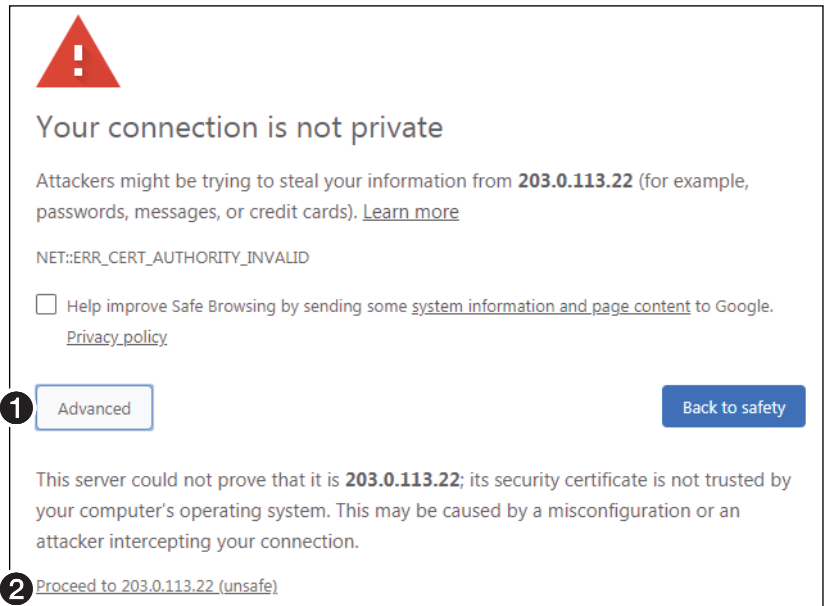
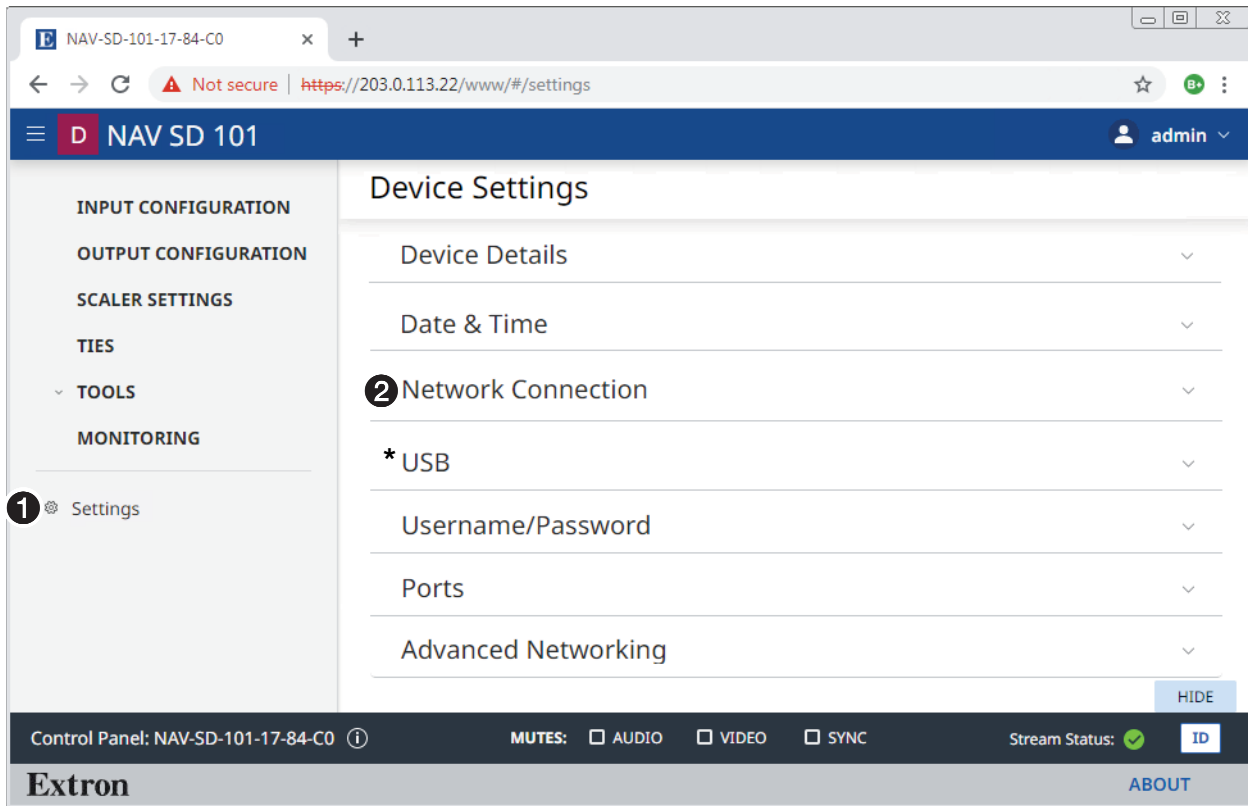

Figure 3. Privacy Error Message (in Chrome Browser)

6. Enter the **username** and **password** in the appropriate fields (see figure 4, ❶ and ❷) and click **Sign In** (❸). The browser opens to the home page of the embedded web pages (see figure 5 on the next page).

NOTES:

- The default username is admin.
- The factory configured passwords for all accounts on this device have been set to the device serial number. If the password is reset, the decoder defaults to the default password, which is extron.
- Usernames and passwords are case sensitive.



* NAV SD 501 only

Figure 5. Home Page

NOTE: Detailed descriptions of communication, configuration, and monitoring are provided in the *NAV SD 501 and NAV SD 101 User Guide*, available at www.extron.com.

Connection settings

View and change connection settings as follows:

1. On the home page, click **Settings** (see figure 5, ①) > **Network Connection** (②). The Network Connection pane opens (see figure 6), showing protected views of the network connection settings.

NOTE: Editing of connection settings is disabled when the device is assigned to an Extron NAVigator System Manager.

2. To change the settings, click **Edit** (see figure 6, ①). The Edit button changes to **Save**.
3. Click in the desired field (②) and edit it as desired.
4. Repeat step 3 as necessary for other values.
5. Click **Save**.

Pairing devices via front panel

Pair devices from the front panel as follows:

1. Use a Tweezer or other small screwdriver to press and hold the **encoder** front panel ID button for approximately 3 seconds, until the ID LED blinks. The encoder enters pairing mode, which allows decoders to receive the AV stream (NAV SD 101) or AV and USB streams (NAV SD 501 only) from encoders.
2. One at a time, use a Tweezer or other small screwdriver to press and hold the front panel **decoder** ID button for approximately 3 seconds, until the ID LED blinks. The decoder is now paired to the encoder.
3. Repeat step 2 for each decoder.

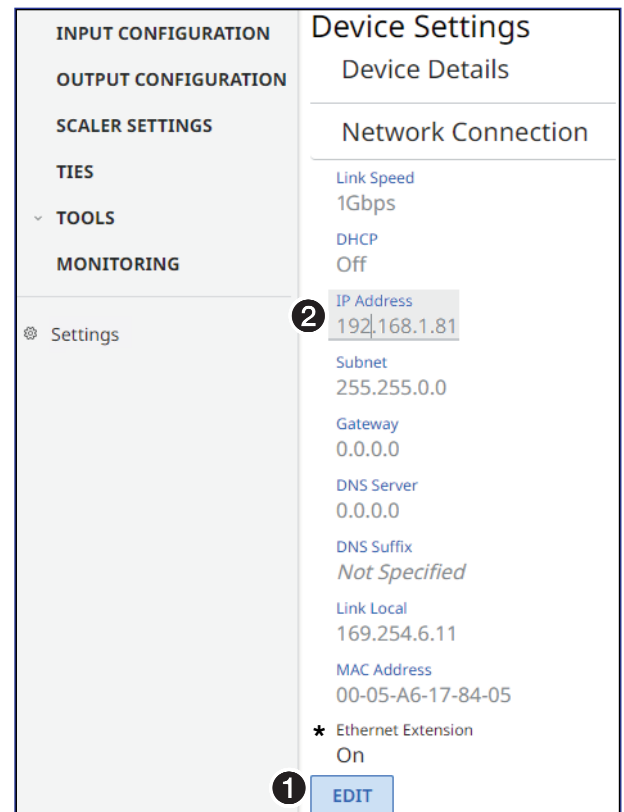

* NAV SD 501 only

Figure 6. Network Connection Pane

NAV SD 501 and NAV SD 101 • Setup Guide (Continued)

- Use a Tweezer or other small screwdriver to press and release the **encoder** front panel **ID** button. The encoder exits pairing mode.
 - Repeat steps 1 through 4 to pair decoders to other encoders.
- After all devices are connected, powered on, and paired, the system is fully operational.

Operation in a System with a NAVigator

The Extron NAVigator is a system manager that easily configures and controls the NAV System. The NAVigator can support a 16 endpoint system by default, but if a LinkLicense is installed, it can support up to 240 endpoints.

See the *NAVigator User Guide*, available at www.extron.com for details.

Connection Details

LockIt® Lacing Brackets

- Plug the HDMI cable or USB (NAV E 501 only) into the panel connection (see **1**, at right).
- Loosen the connection mounting screw from the panel enough to allow the LockIt lacing bracket to be placed over it (**2**). The screw does not have to be removed.
- Place the LockIt lacing bracket on the screw and against the connector (**3**).
- Tighten the screw to secure the bracket.

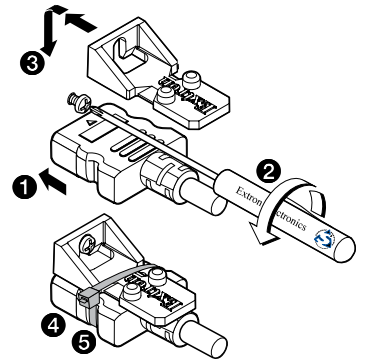

ATTENTION:

- Do not overtighten the HDMI connector mounting screw. The shield it fastens to is very thin and can easily be stripped.
- Ne serrez pas trop la vis de montage du connecteur HDMI. Le blindage auquel elle est attachée est très fin et peut facilement être dénudé.

- Loosely place the included tie wrap around the connector and the LockIt lacing bracket as shown (**4**).
- While holding the connector securely against the lacing bracket, use pliers to tighten the tie wrap, then remove any excess length (**5**).

Analog audio output

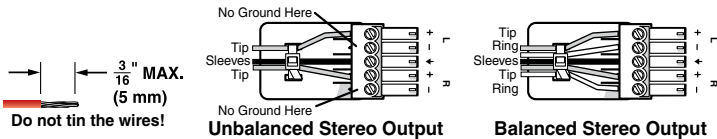

ATTENTION:

- For unbalanced audio, connect the sleeves to the ground contact. **DO NOT** connect the sleeves to the negative (-) contacts.
- Pour l'audio asymétrique, connectez les manchons au contact au sol. **NE PAS** connecter les manchons aux contacts négatifs (-).

Power connector

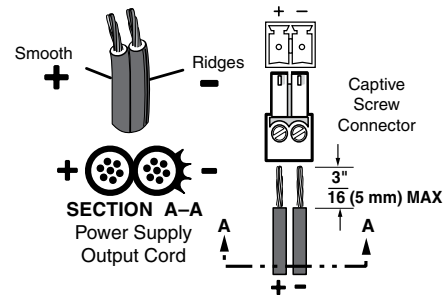

Control connector

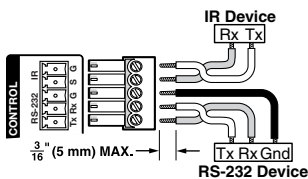

NAV and EXT connectors

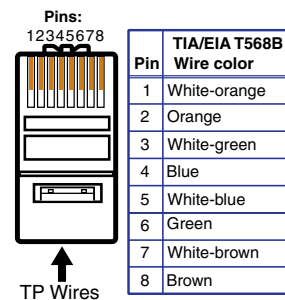

For information on safety guidelines, regulatory compliances, EMI/EMF compatibility, accessibility, and related topics, see the [Extron Safety and Regulatory Compliance Guide](#) on the Extron website.