

## XPA Ultra Series Audio Power Amplifiers • Setup Guide

(XPA U 758, XPA U 358, XPA U 358-70V, XPA U 358-100V, XPA U 358C-70V, XPA U 358C-100V, XPA U 1004, XPA U 1004-70V, XPA U 1004-100V, XPA U 1004C-70V, XPA U 1004C-100V, XPA U 1002, XPA U 1002-70V, XPA U 1002-100V)

**⚠ WARNING:** Installation and service must be performed by experienced, professional installers only.  
**AVERTISSEMENT :** L'installation et l'entretien doivent être effectués par des installateurs professionnels expérimentés.

This guide provides startup instructions for experienced, professional installers to set up and operate the XPA Ultra Series audio power amplifiers. All references are to the *XPA Ultra Series User Guide* which can be found on [www.extron.com](http://www.extron.com).

### Step 1 – Powering Down Equipment

Be sure that power to the amplifier is turned off first.

**ATTENTION:** Adjust the audio level to ∞ (full attenuation) prior to powering the amplifier in Step 7 on page 2.

Turn off all other equipment and disconnect the power cables. Verify that the amplifier is disconnected from the power source before proceeding.

amplifier does not reach or exceed +122 °F (+50 °C). No more than four stacks of XPA Ultra amplifiers should be arranged one-on-top-of-the-other in a rack without an open space between the stacks (see the figure to the right).

XPA Ultra amplifiers can also be arranged above or below another non-XPA Ultra device. In this case, the environment around the amplifier should not reach or exceed +122 °F (+50 °C).

### Step 2 – Captive Screw Audio Cable Wiring

Wire the source output to the amplifier 3.5 mm captive screw input connectors as shown in the following illustrations.

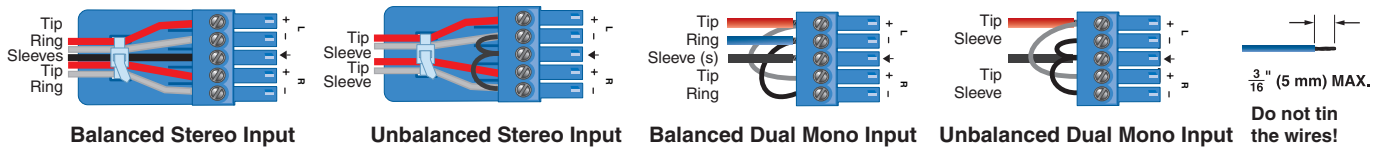

### Step 3 – Speaker Wiring

Wire the speakers to the amplifier output using the included 4-pin, 5 mm captive screw connectors as shown below. Each port has a screw flange to secure the plug to the connector.

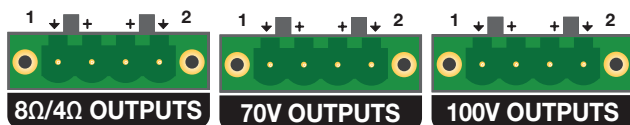

**ATTENTION:**

- Do not tie channel output pins to each other or to ground. Doing so will short out the outputs, damage the amplifier, or both.
- Ne pas lier les sorties 1 et 2 des canaux entre elles ou à la terre. Les sorties pourraient être court-circuitées et/ou l'amplificateur pourrait être endommagé.
- To avoid risk of damage to the amplifier or the speakers, always connect low-impedance speaker loads (8Ω/4Ω) and high-impedance speaker loads (70V) to the appropriately marked output connectors on the amplifier.
- Pour éviter tout risque de détérioration de l'amplificateur ou des enceintes, connectez toujours les charges de l'enceinte faible impédance (8Ω/4Ω) et les charges de l'enceinte haute impédance (70V) aux connecteurs de sortie correctement identifiés sur l'amplificateur.

**NOTE:** You must use Class 2 wiring for this output to comply with UL requirements.

# XPA Ultra Series Audio Power Amplifiers • Setup Guide (Continued)

## Step 4 – Setting the High-Pass Filter (HPF)

On XPA Ultra 70V and 100V models, jumper the **OFF** and **G** pins together to disable the internal 80 Hz high-pass filter. This function should only be used when high-pass filtering is applied to the signal before it reaches the amplifier.



## Step 5 – Remote Port Wiring

On the XPA Ultra Series amplifiers, the 3.5 mm 2-pole captive screw remote port is used to remotely place the amplifier into standby. Connecting the **Standby** pin to the **G** pin places the amplifier in standby mode. Standby mode turns off all output, although the amplifier is still receiving power. Use the included 3.5 mm 2-pole captive screw connector to remotely ground the **Standby** pin. The power indicator LED lights amber when the amplifier is in standby mode.



**NOTE:** A 10k ohm resistor is included in the box. If this resistor is connected between the **Standby** pin and ground, the auto-standby timer is defeated. The **Standby** pin can still be shorted to the ground pin to force the amplifier into standby.

## Step 6 – Powering On Equipment

### ATTENTION:

- The amplifier must be powered on last.
- L'amplificateur doit être mis sous tension en dernier.

Reconnect all power cables and switch on all other equipment before powering on the power amplifier. The front panel power LED of the amplifier lights green.

## Step 7 – Adjusting Attenuation

Adjust the audio attenuation using the rear panel adjustment potentiometers as shown to the right (see Rear Panel Features and Operation in the *XPA Ultra Series User Guide* for more information).

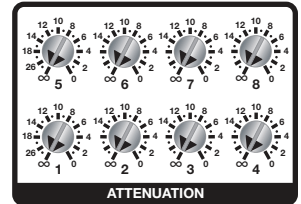

## Step 8 – Checking LEDs

Check the limiter/protect and signal LEDs located on the front and rear panels if problems are encountered (see Rear Panel Features and Operation in the *XPA Ultra Series User Guide* for more information).

## Step 9 – Mounting and Applications

### Rack Mounting

The XPA Ultra Series amplifiers can be rack mounted using one of the following methods.

**NOTE:** See the *XPA Ultra Series User Guide* for instructions on mounting to a rack shelf.

### Rack Ear Mounting (Single Unit)

The XPA Ultra Series amplifiers ship with a set of rack ears so the half rack-width amplifiers can be installed in a full rack-width space.

**Mount the amplifier with the rack ears as follows:**

1. If rubber feet were installed on the bottom of the amplifier, remove them.
2. Attach the included rack ears to the sides of the amplifier with the four provided #6 machine screws (❶ in the next page).
3. Insert the amplifier into the rack, align the holes in the rack ears with the holes on the rack.
4. Secure the amplifier to the rack using four provided 10-32 x 3/4" screws (❷ in the next page).

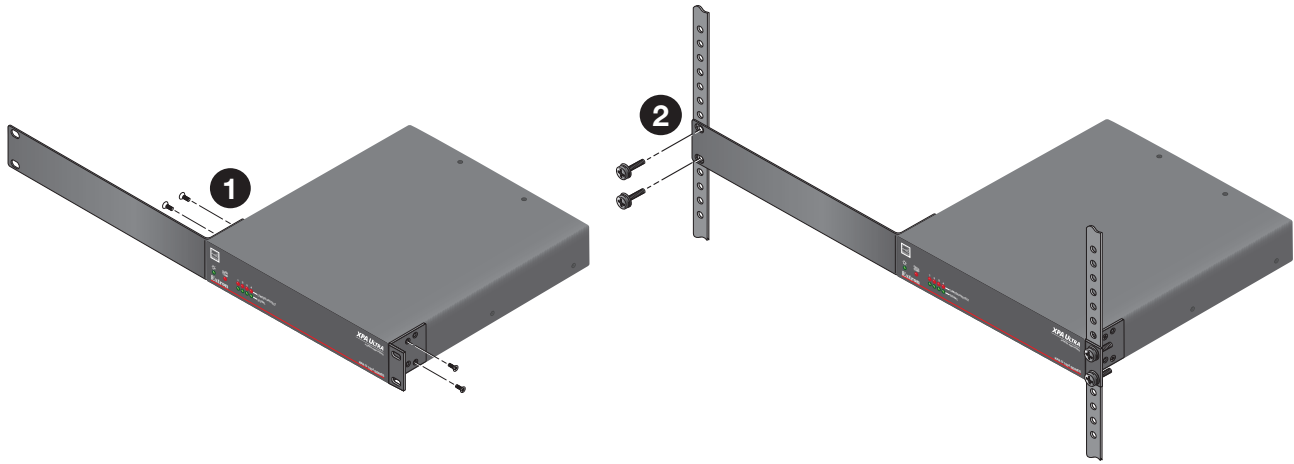

### Bridge Plate Rack Mounting (Side-by-Side Units)

The XPA Ultra Series amplifiers ship with a bridge plate connector for connecting two XPA Ultra Series amplifiers together to form a full rack-width unit.

#### Connect and mount two XPA Ultra Series amplifiers as follows:

1. If rubber feet were installed on the bottom of the amplifiers, remove them.
2. Position the two amplifiers upside down and next to each other (see the figure below).
3. Use the bridge plate connector and four provided #4 machine screws to connect the two amplifiers together (1 below).
4. Attach the two short rack ears to the amplifiers with four provided #6 machine screws (2 below).
5. Insert the amplifiers into the rack, align the holes in the rack ears with the holes on the rack.
6. Secure the amplifier to the rack using four provided 10-32 x 3/4" screws (3 below).

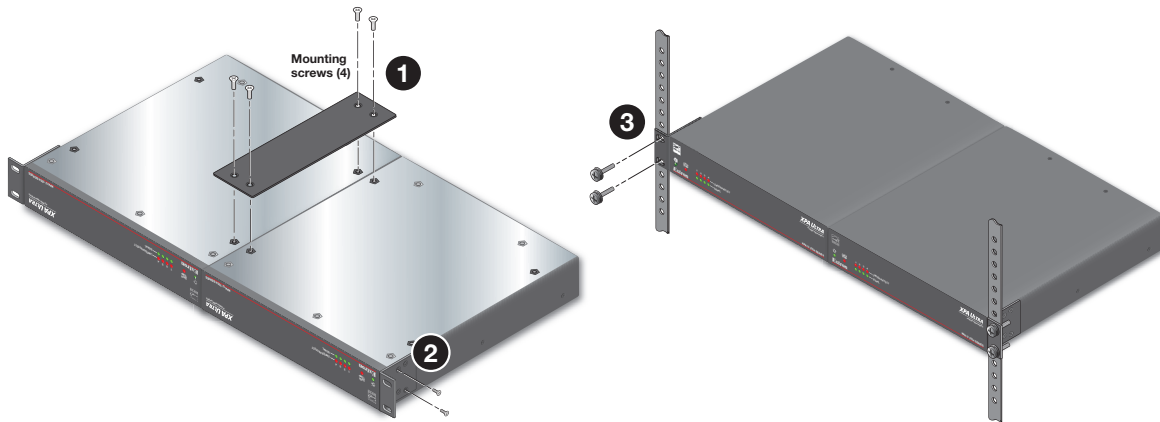

### Rack Mounting Ventilation Recommendations

Excessive heat can decrease the optimal lifetime of the power amplifier. An over temp indicator LED on the front panel of the amplifier lights red whenever the recommended operating temperature has been exceeded.

To reduce the chances of an over temp condition, the XPA Ultra amplifiers should be arranged in a rack environment so the environment around the amplifier does not reach or exceed +122 °F (+50 °C). No more than four stacks of XPA Ultra amplifiers should be arranged one-on-top-of-the-other in a rack without an open space between the stacks (see the figure to the right).

XPA Ultra amplifiers can also be arranged above or below another non-XPA Ultra device. In this case, the environment around the amplifier should not reach or exceed +122 °F (+50 °C).

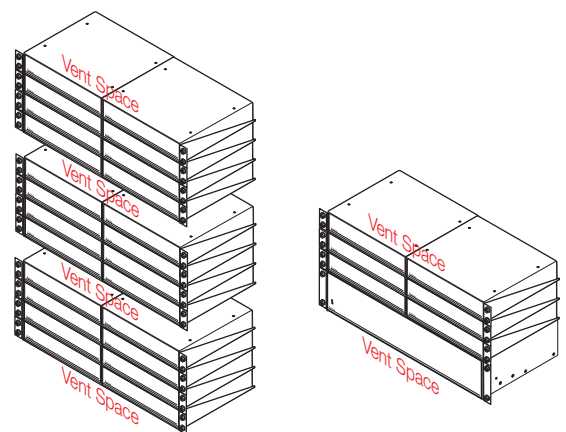

For information on safety guidelines, regulatory compliances, EMI/EMF compatibility, accessibility, and related topics, see the [Extron Safety and Regulatory Compliance Guide](#) on the Extron website.