

BETA 98A Instrument Microphone



General Description

The Shure Beta 98A is a compact, high-output, condenser microphone for professional sound reinforcement and studio recording. An extremely uniform cardioid polar pattern provides excellent gain before feedback and off-axis rejection of unwanted noise. Its high sound pressure level (SPL) capability makes it useful for a variety of acoustic or amplified instruments including drums, piano, reed, wind, and strings.

Variations

- **Beta 98A/C** includes microphone, 7.6 m (25 ft) light-weight interconnect cable, preamplifier, and RK282 shockmount swivel adapter.
- **Beta 98AD/C** includes microphone, 4.6 m (15 ft) heavy-duty interconnect cable, preamplifier, and A98D microphone drum mount.

Features

- Premier live performance microphone with Shure quality, ruggedness, and reliability
- Uniform cardioid pick-up pattern for maximum gain before feedback and superior rejection of off-axis sound
- Tailored frequency response specifically shaped for drums, percussion, reeds, and horns
- Compact design reduces stage clutter
- Wide dynamic range for use in high SPL environments
- Optional A98D mount is unobtrusive, versatile, and easy to adjust
- Enamel-coated metal construction and stainless steel inner grille resist wear and abuse

Performance Characteristics

- Exceptional low-frequency reproduction
- Extremely high SPL handling
- High output level
- No crossover distortion

Shockmount Swivel Adapter

Use the following procedures to mount the Beta 98A on the swivel adapter:

1. Connect the microphone to the adapter.
2. Thread the cable through the C-clamp and slide the connector into the C-clamp until snug.
3. To reduce wear on the cable, snap it into the stress reliever clip leaving 5 to 7 cm (2 to 3 inches) of slack on the connector side.

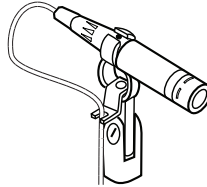

BETA 98A MOUNTED WITH SWIVEL ADAPTER

Interconnecting Cable

The supplied cable connects the BETA 98A to the preamplifier. If necessary, up to 23 m (75 ft) of cable can be used between the microphone and preamplifier without signal loss.

A98D Drum Mount

The Shure A98D mounts the Beta 98A on a drum or cymbal stand. Reference the furnished A98D guide to correctly mount the microphone.

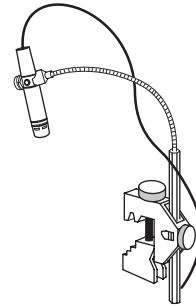

BETA 98A MOUNTED WITH A98D

Applications and Placement

General Rules for Use

- Aim the microphone toward the desired sound source; angle unwanted sounds toward its null point.
- Use the fewest amount of microphones as practical to increase the Potential Acoustic Gain and prevent feedback.
- Follow the 3 to 1 Rule by spacing each microphone by at least three times the distance to its source to reduce Phase Cancellation.
- Place microphones as far as possible from reflective surfaces to reduce Comb Filtering.
- When using directional microphones, work closely to the microphone for extra bass response to take advantage of Proximity Effect.
- Avoid excessive handling to minimize pickup of mechanical noise and vibration.
- Do not cover any part of the microphone grille, as this will adversely affect microphone performance.
- Add a windscreen when using the microphone outdoors.

Load Impedance

Maximum SPL capability, output clipping level, and dynamic range vary with the input load impedance of the preamplifier to which you connect the microphone. Shure recommends a minimum input load impedance of 1000 Ω . Most modern microphone preamplifiers meet this requirement. Higher impedance results in better performance for these specifications.

Power Requirements

This microphone requires phantom power and performs best with a 48 Vdc supply (IEC-61938). However, it will operate with slightly decreased headroom and sensitivity with supplies as low as 11 Vdc.

Most modern mixers provide phantom power. You must use a **balanced** microphone cable: XLR-to-XLR or XLR-to-TRS.

SPECIFICATIONS

Cartridge Type	Electret Condenser	
Polar Pattern	Cardioid	
Frequency Response	20 to 20,000 Hz	
Output Impedance @ 1 kHz	179 Ω	
Sensitivity open circuit voltage, @ 1 kHz, typical	-48.0 dBV/Pa ^[1] (4.0 mV)	
Maximum SPL 1 kHz at 1% THD ^[2]	2500 Ω load	150.5 dB
	1000 Ω load	144.0 dB
Signal-to-Noise Ratio^[3]	64 dB	
Dynamic Range @ 1 kHz	2500 Ω load	120.5 dB
	1000 Ω load	114.0 dB
Clipping Level 20 Hz to 20 kHz, 1% THD	2500 Ω load	8.0 dBV
	1000 Ω load	1.0 dBV
Self Noise equivalent SPL, A-weighted, typical	30.0 dB SPL-A	
Connector	Three-pin professional audio (XLR), male, balanced	
Polarity	Positive pressure on diaphragm produces positive voltage on pin 2 with respect to pin 3	
Power Requirements	11–52 V DC ^[4] phantom power (IEC-61938), 3.6 mA	
Net Weight	12 g (0.6 oz.)	

^[1] 1 Pa=94 dB SPL

^[2]THD of microphone preamplifier when applied input signal level is equivalent to cartridge output at specified SPL

^[3]S/N ratio is the difference between 94 dB SPL and equivalent SPL of self noise, A-weighted

^[4]All specifications measured with a 48 Vdc phantom power supply. The microphone operates at lower voltages, but with slightly decreased headroom and sensitivity.

Accessories and Parts

Furnished Accessories

Zippered Carrying Bag	95A2314
In-Line Preamplifier (1 piece)	RPM626
Snap-fit Windscreen	95A2064
Shock-Mount Swivel Adapter (BETA 98A/C)	RK282
7.6 m (25 ft.) light-weight cable (BETA 98A/C)	95A2398
Beta 98 Drum Mount (BETA 98AD/C)	A98D
4.6 m (15 ft.) Heavy-Duty Cable (BETA 98AD/C)	C98D

Optional Accessories

Metal Locking Windscreen	A412MWS
Universal Microphone Mount	A75M

Replacement Parts

Cardioid Cartridge	RPM98A/C
98A Replacement Housing	RPM98A-HT
Clamp Assembly (A98D)	RPM618
Snap-Fit Windscreen (4 per package)	RK183WS

CERTIFICATION

Eligible to bear CE Marking. Conforms to European EMC Directive 2004/108/EC. Meets Harmonized Standards EN55103-1:1996 and EN55103-2:1996, for residential (E1) and light industrial (E2) environments.

The Declaration of Conformity can be obtained from:

Authorized European representative:
Shure Europe GmbH
Headquarters Europe, Middle East & Africa
Department: EMEA Approval
Wannenacker Str. 28
D-74078 Heilbronn, Germany
Phone: +49 7131 72 14 0
Fax: +49 7131 72 14 14
Email: EMEAsupport@shure.de

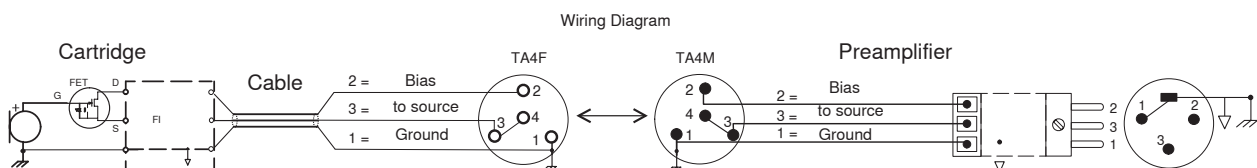

Beta 98A

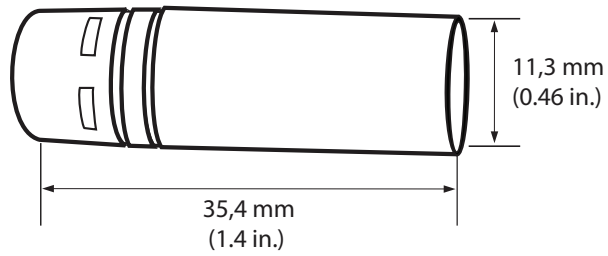
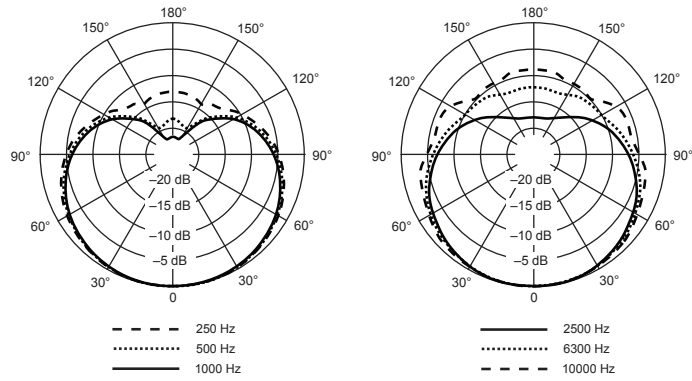
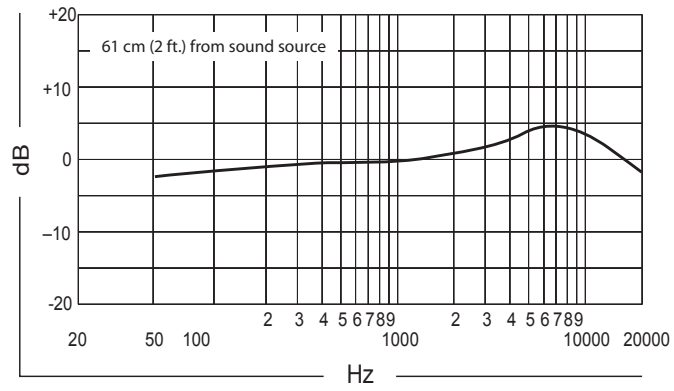

SHURE®