

# Product Specifications

## KSM44A Multi-Pattern Large Dual-Diaphragm Side-Address Condenser Microphone

### Overview

The KSM44A is a premium, large-diaphragm, side-address condenser microphone with multiple polar pattern options (cardioid, omnidirectional, bidirectional). The refined and sophisticated design of the KSM44A features an externally biased, dual 1-inch diaphragms, extensive internal pop filtering and Prethos™ Advanced Preamplifier Technology for a ground-breaking threshold minimum of self-noise. The KSM44A is the premier choice for the highest level of professional studio and stage performance.

### Features

- A milestone technical achievement, Shure's Prethos™ Advanced Preamplifier Technology provides 4dB of self-noise and max SPL of 131 dB for a total dynamic range of 127 dB – an increase of 7 dB that defines the new standard for cleanly nuanced audio capture
- Multiple polar patterns—cardioid, omnidirectional and bidirectional—for maximum flexibility in a wide variety of recording applications
- Dual 1 inch, externally biased, ultra-thin, 2.5 µm, 24 Karat gold-layered, low mass diaphragms provide superior transient response
- Class A, discrete, transformerless preamplifier for transparency, extremely wide frequency response and no crossover distortion. Minimizes harmonic and intermodulation distortions.
- Premium electronic components and gold-plated internal and external connectors
- Subsonic filter eliminates rumble from mechanical vibration below 17 Hz.
- Switchable 15 dB pad for handling extremely high sound pressure levels (SPLs)
- 3-position switchable low-frequency filter helps reduce unwanted stand vibration noise or counteract proximity effect
- Integrated three-stage “pop” protection grille reduces plosives and other breath noise



KSM44A

### Available Models

KSM44A/SL	Includes ShureLock® Suspension Shock Mount, ShureLock® Stand Mount, Carrying Case, and Velveteen Pouch
-----------	--

### Specifications

Cartridge Type	Condenser (externally biased)
Polar Pattern	Cardioid, Omnidirectional, Bidirectional
Frequency Response	20 to 20,000 Hz
Output Impedance	50 ohms
Attenuator Switch	15 dB
Low-Frequency Filter Switch	Flat, -6 dB/octave below 115 Hz, or -18 dB/octave below 80 Hz
Power Requirements	11–52 V DC phantom power (IEC-61938) 5.8 mA, maximum
Common Mode Rejection (10 to 100,000 Hz)	> 50 dB
Common Mode Rejection (20 Hz to 20 kHz)	> 50 dB
Polarity	Positive pressure on diaphragm produces positive voltage on pin 2 with respect to pin 3
Net Weight	492 g (17.4 oz.)
Connector	Three-pin professional audio (XLR), male, balanced

		Cardioid	Omnidirectional	Bidirectional			
Sensitivity (open circuit voltage, @ 1 kHz, typical)		-31 dBV / Pa <sub>rms</sub> (29.8 mV)	-37 dBV / Pa <sub>rms</sub> (14.8 mV)	-36 dBV / Pa <sub>rms</sub> (16.8 mV)			
Self Noise (equivalent SPL <sub>A</sub> - weighted, typical)		4 dB SPL-A	6 dB SPL-A	7.5 dB SPL-A			
Preamplifier Distortion (at 1 kHz, 94 dB SPL)		<0.00 1%					
Signal-to-Noise Ratio		90 dB	88 dB	86.5 dB			
Clipping Level (20 Hz to 20 kHz, 1% THD)	2500 $\hat{E}$ load	9 dBV					
	1000 $\hat{E}$ load	6 dBV					
Dynamic Range (@ 1k Hz)	2500 $\hat{E}$ load	130 dB	134 dB	131 dB			
	1000 $\hat{E}$ load	127 dB	131 dB	128 dB			
Maximum SPL (1 kHz at 1% THD) *		PAD OFF	PAD ON	PAD OFF	PAD ON	PAD OFF	PAD ON
	2500 $\hat{E}$ load	134 dB SPL	150 dB SPL	140 dB SPL	152 dB SPL	139 dB SPL	151 dB SPL
	1000 $\hat{E}$ load	131 dB SPL	147 dB SPL	137 dB SPL	149 dB SPL	136 dB SPL	148 dB SPL

# Product Specifications *(KSM44A, Continued)*

## Furnished Accessories

<b>A44AM</b>	ShureLock® Stand Mount	<b>AK44AC</b>	Zippered Carrying Case	<b>A44ASM</b>	ShureLock® Elastic Shock Mount
<b>RK383</b>	Suspension Shock Mount Elastic Cord, Cristal (contains two)	<b>A44AVB</b>	Protective Velveteen Pouch		

### Polar Pattern

#### Omnidirectional

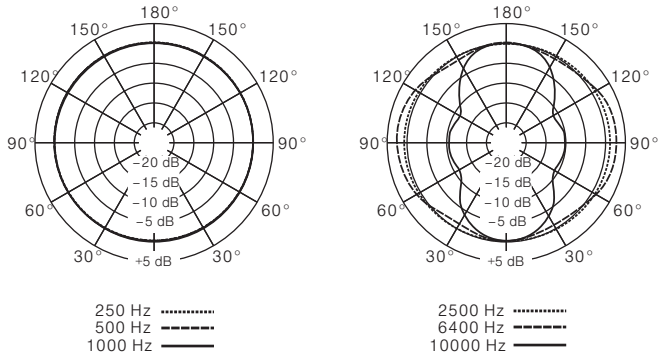

### Frequency Response

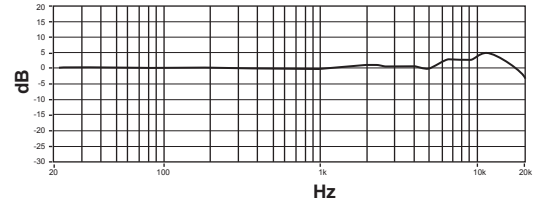

#### Cardioid

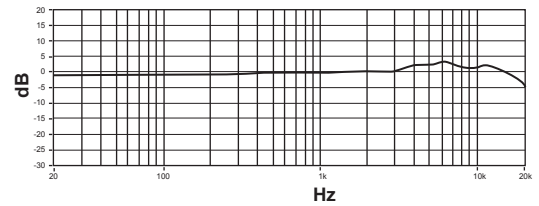
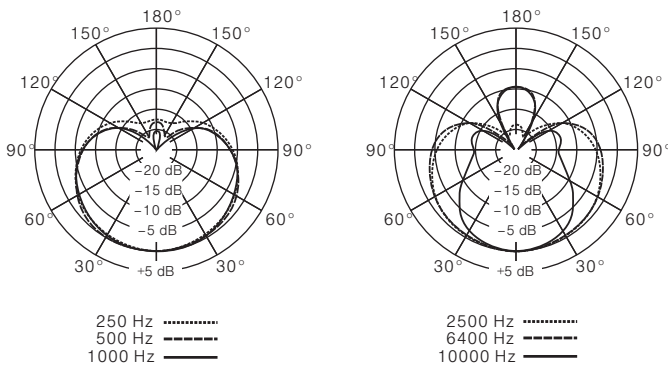

#### Bidirectional

