

**PROTEUS HYBRID &
PROTEUS HYBRID WMG**
User Manual

©2023 ELATION PROFESSIONAL all rights reserved. Information, specifications, diagrams, images, and instructions herein are subject to change without notice. ELATION PROFESSIONAL logo and identifying product names and numbers herein are trademarks of ELATION PROFESSIONAL. Copyright protection claimed includes all forms and matters of copyrightable materials and information now allowed by statutory or judicial law or hereinafter granted. Product names used in this document may be trademarks or registered trademarks of their respective companies and are hereby acknowledged. All non-ELATION brands and product names are trademarks or registered trademarks of their respective companies.

ELATION PROFESSIONAL and all affiliated companies hereby disclaim all liabilities for property, equipment, building, and electrical damages, injuries to any persons, and direct or indirect economic loss associated with the use or reliance of any information contained within this document, and/or because of the improper, unsafe, insufficient, and negligent assembly, installation, rigging, and operation of this product.

Elation Professional USA | 6122 S. Eastern Ave. | Los Angeles, CA. 90040
323-582-3322 | 323-832-9142 fax | www.elationlighting.com | info@elationlighting.com

Elation Professional B.V. | Junostraat 2 | 6468 EW Kerkrade, The Netherlands
+31 45 546 85 66 | +31 45 546 85 96 fax | www.elationlighting.eu | info@elationlighting.eu

Elation Professional Mexico | AV Santa Ana 30 | Parque Industrial Lerma, Lerma, Mexico 52000
+52 (728) 282-7070

DOCUMENT VERSION



Due to additional product features and/or enhancements, an updated version of this document may be available online. Please scan the QR Code with your mobile device or visit www.elationlighting.com for the latest revision/update of this manual before installation and/or programming.

Date	Document Version	Software Version ≥	DMX Channel Modes	Notes
07/07/17	1	1.3.1A	24 / 26 / 37	Initial release.
08/17/17	1.2	N/C	N/C	Updated error codes, rigging illustration.
12/03/17	1.4	N/C	N/C	Updated installation, E-Fly, and gobo sections.
01/03/18	1.6	1.6.0	N/C	Updated System Menus and added Movement and Focus Zoom Speed controls.
07/27/18	1.8	1.6.2	N/C	Added dimming curves to DMX channels 24/26/37.
08/15/18	1.9	N/C	N/C	Added POTENTIAL INTERNAL FIXTURE DAMAGE FROM EXTERNAL SOURCES OF LIGHT BEAMS section.
9/24/18	2.0	1.64	N/C	Updated LAMP CONTROL system menu.
11/25/18	2.2	N/C	N/C	Added LAMP and GOBO replacement instructions.
10/10/19	2.4	N/C	N/C	Included RJ45 data cable note added.
09/29/20	2.6	N/C	N/C	Updated specifications
02/15/21	2.8	1.6.7	N/C	Updated primary/secondary modes. Added Baking Test update. Hibernation / Sun protection warning and information. Added V1.6.4, V1.6.5, & V1.6.6 additions/changes to DMX traits.
03/24/21	3.0	N/C	N/C	Updated General Information and Maintenance, Added Proteus Hybrid WMG to cover title.
05/20/21	3.2	N/C	N/C	Updated Maintenance.
01/17/22	3.4	1.7.0	N/C	Updated General Information and Specifications
08/23/22	3.6	N/C	N/C	Updated Lamp Installation, Fixture Installation, added RDM
11/23/22	3.8	1.8.0	N/C	Update System Menu & DMX Traits
02/06/23	4.0	N/C	N/C	Added IP65 Rated and Animation Wheel; updated General Info, RDM, System Menu, DMX Traits, Dimensional Drawings, Specifications
05/08/23	4.2	N/C	N/C	Updated Specifications and Dimensional Drawings
06/08/23	4.4	N/C	N/C	Added Center to Center dimension to Dimensional Drawings, removed tipping page

CONTENTS

GENERAL INFORMATION	4
IP65 RATED	5
LIMITED WARRANTY (USA ONLY)	6
SAFETY GUIDELINES	7
DISCHARGE LAMP WARNING	9
OVERVIEW	10
LAMP INSTALLATION	11
GOBO INSTALLATION	19
FIXTURE INSTALLATION	28
REMOTE DEVICE MANAGEMENT (RDM)	33
SYSTEM MENU	34
E-FLY WIRELESS DMX SET UP	40
DMX CHANNEL FUNCTIONS AND VALUES	41
ERROR CODES	48
MAINTENANCE	53
SPECIFICATIONS	54
COLORS AND GOBOS ANIMATION WHEEL	55
DIMENSIONAL DRAWINGS	56
OPTIONAL ACCESSORIES FCC STATEMENT	57

GENERAL INFORMATION

INTRODUCTION

Please read and understand the instructions in this manual carefully and thoroughly before attempting to operate this device. These instructions contain important safety and use information. **This product is intended to be used by professionally trained personnel only, and is not suitable for private use.**

COOLING

After usage, the lamp may be switched off, but the fixture should remain connected to power to allow the fan time to cool down the fixture.

UNPACKING

Every device has been thoroughly tested and has been shipped in perfect operating condition. Carefully check the shipping carton for damage that may have occurred during shipping. If the carton is damaged, carefully inspect the device for damage, and be sure all accessories necessary to install and operate the device have arrived intact. In the event damage has been found or parts are missing, please contact our customer support team for further instructions. Please do not return this device to your dealer without first contacting customer support. Please do not discard the shipping carton in the trash. Please recycle whenever possible.

BOX CONTENTS

Omega Brackets (x2)

IP65 Rated 5pin DMX Cable

IP65 Rated RJ45 Cable (Fixture to Fixture Interconnect Use Only!)

IP65 Power Cable

CUSTOMER SUPPORT

Contact **ELATION Service** for any product related service and support needs. Also visit forums.elationlighting.com with questions, comments, or suggestions.

ELATION SERVICE USA - Monday - Friday 8:00am to 4:30pm PST
323-582-3322 | Fax 323-832-9142 | support@elationlighting.com

ELATION SERVICE EUROPE - Monday - Friday 08:30 to 17:00 CET
+31 45 546 85 63 | Fax +31 45 546 85 96 | support@elationlighting.eu

REPLACEMENT PARTS please visit parts.elationlighting.com

IP65 RATED

The **International Protection (IP)** rating system is commonly expressed as “IP” (Ingress Protection) followed by two numbers (i.e. IP65), where the numbers define the degree of protection. The first digit (Foreign Bodies Protection) indicates the extent of protection against particles entering the fixture, and the second digit (Water Protection) indicates the extent of protection against water entering the fixture. An IP65 rated lighting fixture is designed and tested to protect against the ingress of dust (6), and low-pressure water jets from any direction (5).

NOTE: THIS FIXTURE IS INTENDED FOR TEMPORARY OUTDOOR USE ONLY!

Maritime/Coastal Environment Installations: A coastal environment is seaside adjacent, and caustic to electronics through exposure to atomized salt-water and humidity, whereas maritime is anywhere within 5-miles of a coastal environment. A waterproof dome or similar device is recommended for use in permanent outdoor installations.



NOT suitable for maritime/coastal environment installations. Installing this fixture in a maritime/coastal environment may cause corrosion and/or excessive wear to the interior and/or exterior components of the fixture. Damages and/or performance issues resulting from installation in a maritime/coastal environment will void the manufacturer’s warranty, and will NOT be subject to any warranty claims and/or repairs.

Maritime installations require additional preparation, and additional service intervals may be needed given the maritime use. In general, IP ratings presuppose freshwater conditions VS maritime conditions, which are typically more “caustic” to IP fixtures (both internally and externally). A duty-cycle may also be needed when units are not in use. During times of high humidity and colder temperatures, condensation may occur internally so the fixture may require a duty-cycle to bring it up to running temperature, allowing any accumulation of moisture to be expelled via the vent valve. Recommendations can change based on installation environmental circumstances. A waterproof dome or similar device is recommended for use in permanent outdoor installations. When using a dome, refer to manufacturer recommendations for duty-cycle.

Exterior Maintenance: Inspect the exterior every 30-days. The chassis should be inspected for any signs of contaminants. Inspect optics to determine if the lens is obstructed, then clean optics and chassis accordingly. Based on initial finding, schedule maintenance accordingly, keeping in mind that exterior maintenance will be required. Even if the luminaires are NOT in use, maintenance will still be needed given its location (exterior use). The use of a durable type of wax on the chassis is recommended since it will help prevent contaminant build up. Inspect both power and data lines for any signs of contaminants or corrosion. Periodically reapplying di-electric grease, especially in coastal environments. If any signs of corrosion/contaminants are present, clean thoroughly, and/or replace connectors, then reapply di-electric grease. Typically, this should be done annually, or any time an opportunity presents itself. As a preventive measure, annual replacement of both vent valves is recommended. The vent valve membrane can become contaminated and/or clogged causing improper venting of humidity within the luminaire. Inspect all mounting hardware as a precaution.

Interior Maintenance: An internal inspection of the head is recommended within the first 1,000-1,500 hours of use. The unit must be powered off/disconnected.

- Inspect zoom/focus mechanism, clean optics, lubricate linear bearings (Krytox oil) as needed, inspect belts for wear
- Inspect all rotating effect wheels, manually rotate them, note any resistance
- Inspect all remaining rotating belts for any wear
- Inspect all fans, clean as needed, check rotation, check connections
- Inspect CMY module, manually move flags and check for signs of resistance, and if needed, clean guide rods first, then reapply a thin layer of grease (moly lube)
- Clean interior with low-volume compressed air, then clean optics prior to reassembly of head covers

Although the base has limited moving parts, the pan belt should also be inspected for wear. Remember to always perform an IP test anytime a cover is removed.

There is no specific time frame regarding the routine replacement of parts such as belts/stepper motors, PCBs, or LEDs. These items should only be replaced on an as needed bases, except for cooling fans, which should be replaced once the luminaries reach 10,000-hours. This is a prophylactic measure intended to keep the unit running as cool as possible, insuring proper function of all internal components. A complete service breakdown is available, please contact service@elationlighting.com for any needed parts or manuals.

LIMITED WARRANTY (USA ONLY)

1. Elation Professional hereby warrants, to the original purchaser, Elation Professional products to be free of manufacturing defects in material and workmanship for a period of two years (730 days), and Elation Professional product rechargeable batteries to be free of manufacturing defects in material and workmanship for a period of six months (180 days), from the original date of purchase. This warranty excludes discharge lamps and all product accessories. This warranty shall be valid only if the product is purchased within the United States of America, including possessions and territories. It is the owner's responsibility to establish the date and place of purchase by acceptable evidence, at the time service is sought.
2. For warranty service, send the product only to the Elation Professional factory. All shipping charges must be pre-paid. If the requested repairs or service (including parts replacement) are within the terms of this warranty, Elation Professional will pay return shipping charges only to a designated point within the United States. If any product is sent, it must be shipped in its original package and packaging material. No accessories should be shipped with the product. If any accessories are shipped with the product, Elation Professional shall have no liability whatsoever for loss and/or or damage to any such accessories, nor for the safe return thereof.
3. This warranty is void if the product serial number and/or labels are altered or removed; if the product is modified in any manner which Elation Professional concludes, after inspection, affects the reliability of the product; if the product has been repaired or serviced by anyone other than the Elation Professional factory unless prior written authorization was issued to purchaser by Elation Professional; if the product is damaged because not properly maintained as set forth in the product instructions, guidelines and/or user manual.
4. This is not a service contract, and this warranty does not include any maintenance, cleaning or periodic check-up. During the periods as specified above, Elation Professional will replace defective parts at its expense, and will absorb all expenses for warranty service and repair labor by reason of defects in material or workmanship. The sole responsibility of Elation Professional under this warranty shall be limited to the repair of the product, or replacement thereof, including parts, at the sole discretion of Elation Professional. All products covered by this warranty were manufactured after January 1, 1990, and bare identifying marks to that effect.
5. Elation Professional reserves the right to make changes in design and/or performance improvements upon its products without any obligation to include these changes in any products theretofore manufactured.
6. No warranty, whether expressed or implied, is given or made with respect to any accessory supplied with the products described above. Except to the extent prohibited by applicable law, all implied warranties made by Elation Professional in connection with this product, including warranties of merchantability or fitness, are limited in duration to the warranty periods set forth above. And no warranties, whether expressed or implied, including warranties of merchantability or fitness, shall apply to this product after said periods have expired. The consumer's and/or dealer's sole remedy shall be such repair or replacement as is expressly provided above; and under no circumstances shall Elation Professional be liable for any loss and/or damage, direct and/or consequential, arising out of the use of, and/or the inability to use, this product.
7. This warranty is the only written warranty applicable to Elation Professional products and supersedes all prior warranties and written descriptions of warranty terms and conditions heretofore published.

WARRANTY RETURNS

All returned service items whether under warranty or not, must be freight pre-paid and accompanied by a return authorization (R.A.) number. The R.A. number must be clearly written on the outside of the return package. A brief description of the problem, as well as the R.A. number, must also be written down on a piece of paper and included in the shipping container. If the unit is under warranty, you must provide a copy of your proof of purchase invoice. Items returned without an R.A. number clearly marked on the out-side of the package will be refused and returned at customer's expense. You may obtain an R.A. number by contacting customer support.

SAFETY GUIDELINES

To guarantee a smooth operation, it is important to follow all instructions and guidelines in this manual. Elation Professional is not responsible for injury and/or damages resulting from the misuse of this fixture due to the disregard of the information printed in this manual. Only qualified and/or certified personnel should perform installation of this fixture and only the original rigging parts included with this fixture should be used for installation. Any modifications to the fixture and/or the included mounting hardware will void the original manufacturer's warranty and increase the risk of damage and/or personal injury.



PROTECTION CLASS 1 - FIXTURE MUST BE PROPERLY GROUNDED



THERE ARE NO USER SERVICEABLE PARTS INSIDE THIS UNIT.

DO NOT ATTEMPT ANY REPAIRS YOURSELF; DOING SO WILL VOID YOUR MANUFACTURER'S WARRANTY. DAMAGES RESULTING FROM MODIFICATIONS TO THIS FIXTURE AND/OR THE DISREGARD OF SAFETY INSTRUCTIONS AND GUIDELINES IN THIS MANUAL VOID THE MANUFACTURER'S WARRANTY, AND ARE NOT SUBJECT TO ANY WARRANTY CLAIMS AND/OR REPAIRS.



**DO NOT PLUG FIXTURE INTO A DIMMER PACK!
NEVER OPEN THIS FIXTURE WHILE IN USE!
UNPLUG POWER BEFORE SERVICING FIXTURE!
NEVER TOUCH FIXTURE DURING OPERATION, AS IT MAY BE HOT!
KEEP FLAMMABLE MATERIALS AWAY FROM FIXTURE!**



ENSURE ALL CONNECTIONS AND END CAPS ARE PROPERLY SEALED WITH A DIELECTRIC GREASE (AVAILABLE AT MOST ELECTRICAL SUPPLIERS) TO PREVENT WATER CORROSION AND/OR ELECTRICAL SHORT CIRCUIT.



IF THE FIXTURE IS EXPOSED TO ENVIRONMENTAL TEMPERATURE CHANGES SUCH AS RELOCATION FROM AN OUTDOOR COLD TO AN INDOOR WARM ENVIRONMENT, DO NOT POWER THE FIXTURE ON IMMEDIATELY. INTERNAL CONDENSATION AS A RESULT OF ENVIRONMENTAL TEMPERATURE CHANGE CAN CAUSE INTERNAL FIXTURE DAMAGE. LEAVE THE FIXTURE POWERED OFF UNTIL IT HAS REACHED ROOM TEMPERATURE BEFORE POWERING ON.

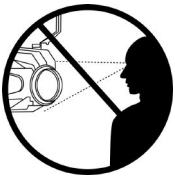

**NEVER LOOK DIRECTLY INTO THE LIGHT SOURCE!
RETINA INJURY RISK - MAY INDUCE BLINDNESS!
SENSITIVE PERSONS MAY SUFFER AN EPILEPTIC SHOCK!**



**MINIMUM DISTANCE TO OBJECTS/SURFACES
MUST BE 40 FEET (12 METERS)
MAXIMUM TEMP OF EXTERNAL SURFACE 212° F (100°C)
MINIMUM DISTANCE OF INFLAMMABLE MATERIALS
FROM THE SURFACE 5.0 FEET (1.5 METER)**

SAFETY GUIDELINES

CAUTION

**HIGH
INTENSITY
ULTRAVIOLET
LIGHT**



AVOID DIRECT EYE & SKIN EXPOSURE.
WEAR PROPER EYE & SKIN PROTECTION.
SEE MANUAL FOR SAFETY INSTRUCTIONS.

RISK GROUP 3 - RISK OF EXPOSURE TO ULTRAVIOLET UV RADIATION! FIXTURE EMITS HIGH INTENSITY WAVELENGTH OF ULTRAVIOLET UV LIGHT FROM THE UV COLOR FILTER. WEAR PROPER EYE AND SKIN PROTECTION. AVOID PROLONGED PERIODS OF EXPOSURE TO UV COLOR FILTER. AVOID WEARING WHITE COLOR CLOTHING AND/OR USING UV PAINTS ON SKIN. AVOID DIRECT EYE AND/OR SKIN EXPOSURE AT DISTANCES LESS THAN 11 feet (3.3m). DO NOT OPERATE FIXTURE WITH DAMAGED/MISSING EXTERNAL COVERS. DO

NOT LOOK DIRECTLY INTO THE UV LIGHT AND/OR VIEW UV LIGHT DIRECTLY WITH OPTICAL INSTRUMENTS THAT MAY CONCENTRATE THE LIGHT/RADIATION OUTPUT. INDIVIDUALS SUFFERING FROM A RANGE OF EYE CONDITIONS, SUNLIGHT EXPOSURE DIS-ORDERS, OR INDIVIDUALS USING PHOTOSENSITIVE MEDICATION, MAY RECEIVE DISCOMFORT IF EXPOSED TO THE ULTRAVIOLET UV LIGHT EMITTED FROM THE UV LED.

DO NOT TOUCH the fixture housing during operation. Turn OFF the power and allow approximately 60 minutes for the fixture to cool down before serving.

DO NOT shake fixture, avoid brute force when installing and/or operating fixture.

DO NOT operate fixture if the power cord is frayed, crimped, damaged and/or if any of the power cord connectors are damaged and do not insert into the fixture securely with ease. **NEVER** force a power cord connector into the fixture. If the power cord or any of its connectors are damaged, replace it immediately with a new one of similar power rating.

DO NOT block any air ventilation slots.

All fan and air inlets must remain clean and never blocked.

Allow approx. 6" (15cm) between fixture and other devices or a wall for proper cooling. Always disconnect fixture from main power source before performing any type of service and/or cleaning procedure. Only handle the power cord by the plug end, never pull out the plug by tugging the wire portion of the cord.

During the initial operation of this fixture, a light smoke or smell may emit from the interior of the fixture. This is a normal process and is caused by excess paint in the interior of the casing burning off from the heat associated with the lamp and will decrease gradually over time.

Consistent operational breaks will ensure fixture will function properly for many years.

ONLY use the original packaging and materials to transport the fixture in for service.

DISCHARGE LAMP WARNING

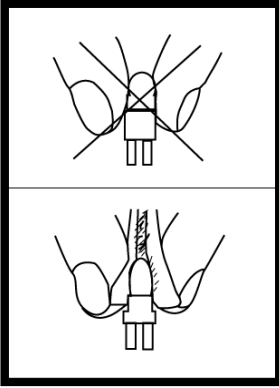

This fixture is fitted with a DISCHARGE LAMP, which is highly susceptible to damage if improperly handled. NEVER touch the lamp with your bare hands, as the oil from your hands will shorten the life of the lamp. Also, NEVER move the fixture until the lamp has had ample time to cool. Lamps are NOT covered under warranty conditions. Avoid switching the fixture ON and OFF repeatedly in short intervals, as this will reduce lamp life and intensity. To achieve the intensity associated with discharge lamps, these lamps use gas sealed in a high-pressure environment to emit a brilliant output.

Due to the high pressure involved with the construction of the lamp, the lamp MAY EXPLODE DURING PROLONGED EXTENSIVE USE. This risk is increased with age; added care is encouraged when dealing with older lamps. Thus, the lamp must always be replaced at the end of their recommended duty cycle. Extreme caution should be used when operating this or any fixture fitted with a gas discharge lamp.



UV RADIATION NOTICE

This fixture emits intense UV radiation, which is harmful to the eyes and skin. The intense luminance of the lamp can cause severe damage to the retina. NEVER operate this fixture with ANY of the protective covers removed. These covers have been specially designed to shield against UV radiation.



LAMP REPLACEMENT

Please note that due to the nature of the Philips™ Platinum 21R Lamp and the optical path of the fixture, the lamp MUST BE replaced at 1,500 hours. Use only Genuine Original Philips™ Platinum 21R Lamps. Other brand lamps may cause damage and void warranty!

OVERVIEW

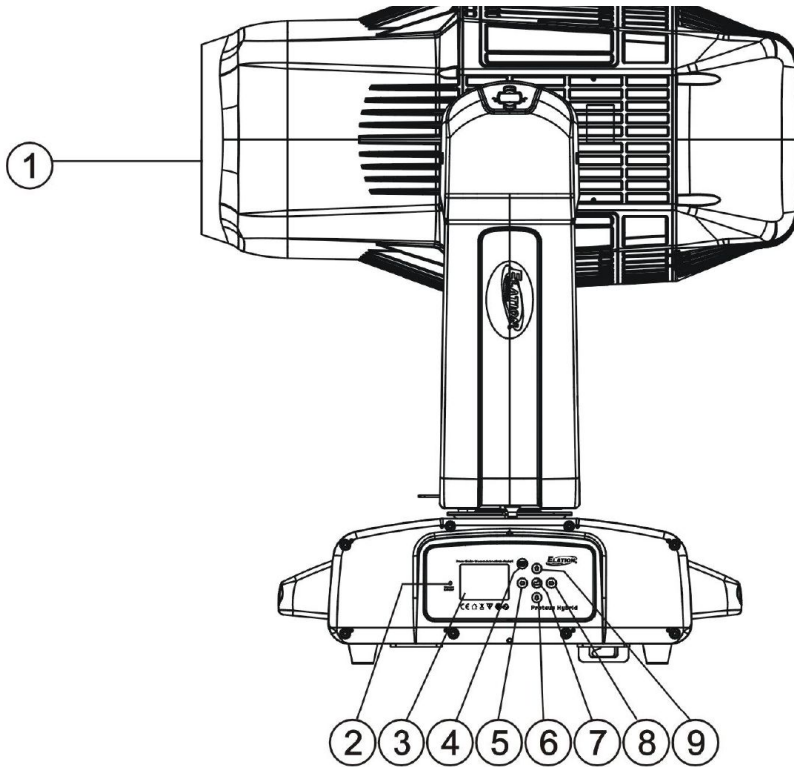

1. Lens
2. E-FLY Wireless DMX Indicator LED
3. LCD Menu Control Display
4. MODE/ESC Button
5. LEFT Button
6. DOWN Button
7. ENTER Button
8. RIGHT Button
9. UP Button
10. Power IN
11. Fuse
12. RJ45 Ethernet IN
13. Gore Valve
14. RJ45 Ethernet OUT
15. 5pin DMX IN
16. 5pin DMX OUT

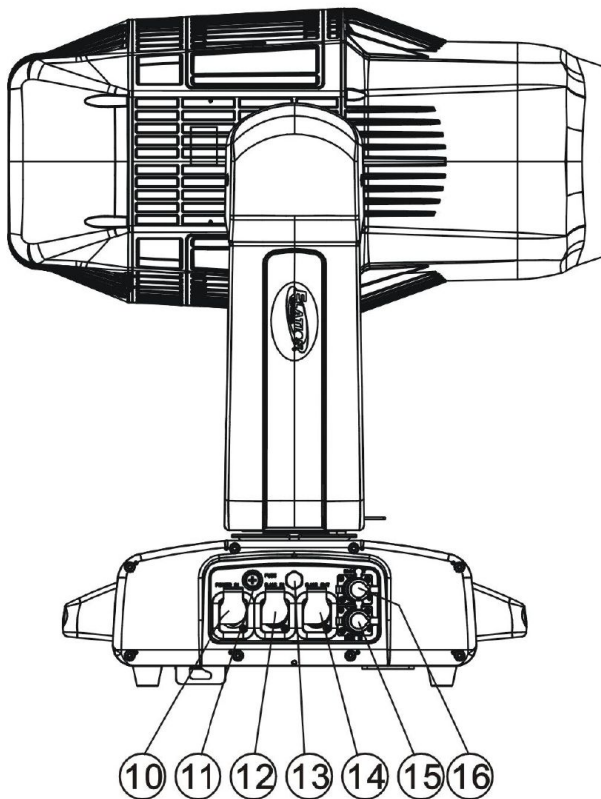

LAMP INSTALLATION



LAMP REPLACEMENT

Please note that due to the nature of the Philips™ Platinum 21R Lamp and the optical path of the fixture, the lamp **MUST BE** replaced at 1,500 hours.

Use only Genuine Original Philips™ Platinum 21R Lamps. Other brand lamps may cause damage and void warranty!

INSTALLING OR REPLACING THE LAMP

To ensure a proper/safe lamp change, carefully read all the following instructions.

LAMP PROTECTION CIRCUITRY

Because of the nature of the extreme heat associated with the **Philips™ Platinum 21 R** lamp and the unique IP65 rated sealed optical system, it is **IMPERATIVE** that the lamp be replaced at **1,500 Hours** or sooner. This is done to protect the internal sealed optical system as well as prevent accidental lamp explosion, which could lead to hot glass particles falling from the fixture.

FAILURE TO CHANGE THE LAMP WITHIN 300 HOURS of the 1,500 HOUR RATED LIFE, WILL CAUSE THE FIXTURE TO AUTOMATICALLY SHUT DOWN!

At **1,500 Hours** the LCD control display will begin to flash, **“Replace The Lamp”** and the lamp will flicker for the first five minutes of operation. At this point the lamp has reached the maximum rated life and should be replaced immediately. After the lamp has flickered for about five minutes it should strike normally allowing the fixture to be used temporarily until a replacement lamp can be installed. The fixture will continue to operate for an additional 300 hours; however, the **“Replace the Lamp”** warning will continue to flash in the display. Keep in mind that the flicker protection circuitry will only work for about 300 Hours (lamp clock life of 1,500-1,800 Hours).

After 1,800 Hours the fixture will no longer respond to DMX commands and immediately enter a hibernation mode that will electronically discontinue all fixture functionality except for a few menu commands. The fixture will continue to enter hibernation mode until the lamp is replaced and the lamp clock has been reset. To replace the lamp, follow the safety guidelines and procedures listed on the next page.

LAMP INSTALLATION



WARNING! LAMP REPLACEMENT SHOULD ONLY BE DONE BY A TRAINED TECHNICIAN.

1. Turn OFF power and allow approximately 60 minutes for the fixture to cool down.



2. Place head in a right-angle horizontal position and engage both the **PAN** and **TILT** locks for added stability while replacing the lamp.



3. Remove (4x) 3mm hex-head screws to remove rear cover.

LAMP INSTALLATION



4. Unclip the rear cover safety cable.

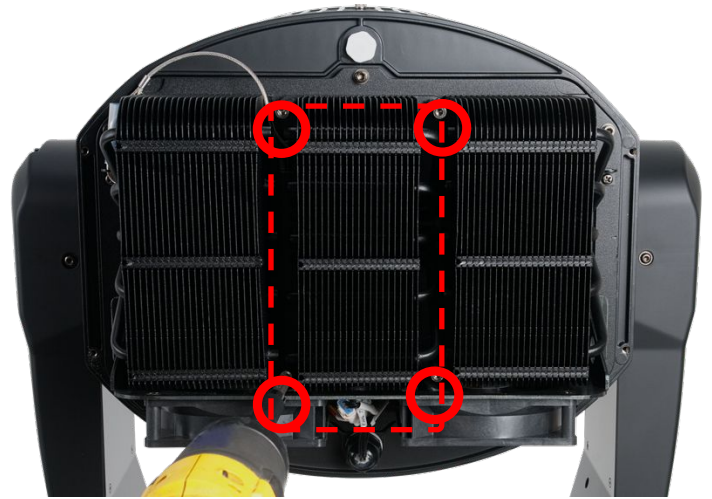

5. Remove (4x) 3mm hex-head screws holding the center heatsink module.



6. Unclip the center heatsink module safety cable.



LAMP INSTALLATION

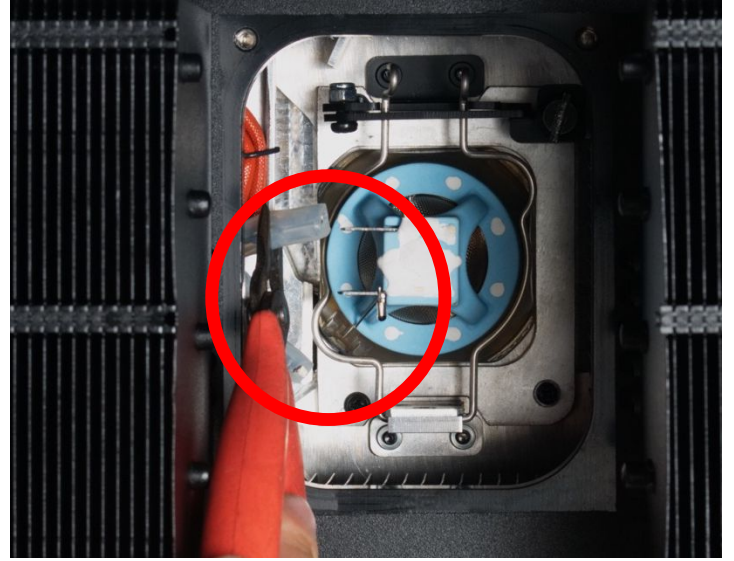
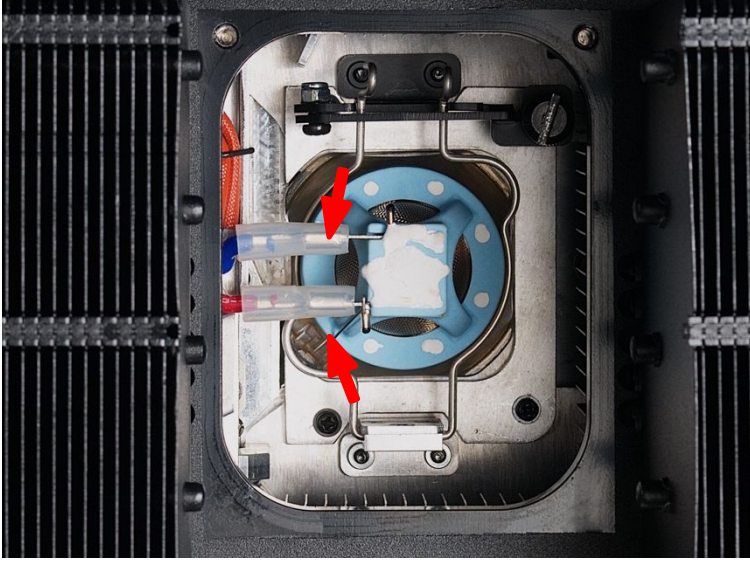

7. Gently remove the (2x) spade terminals connected to the lamp.

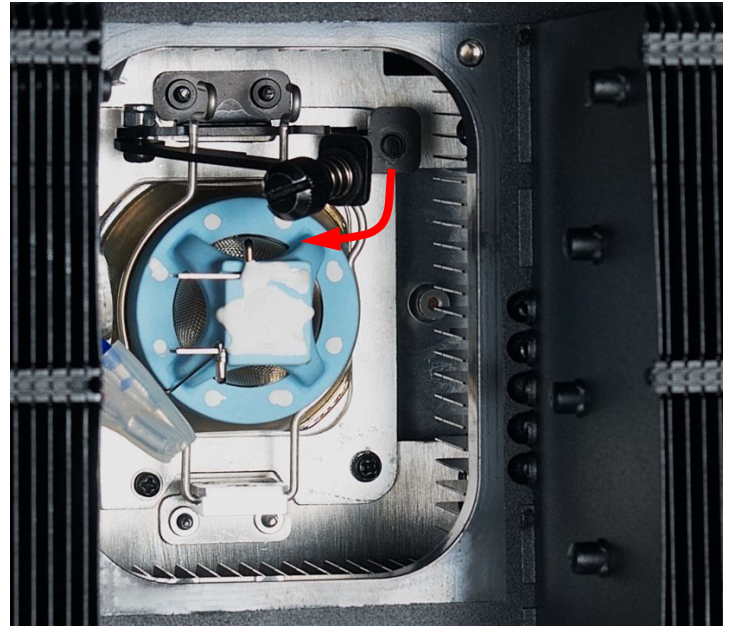
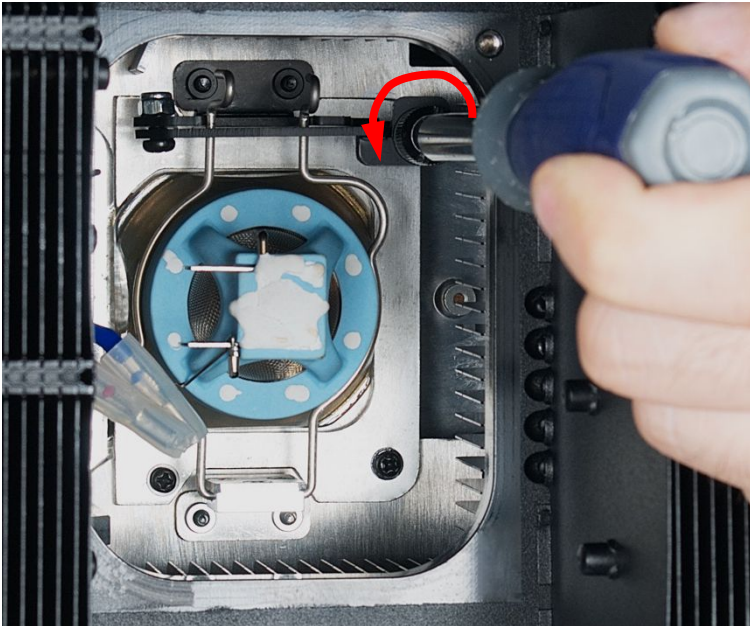

8. Loosen the lamp retaining arm screw and the pull arm out. Then unclip the lamp retaining clip

LAMP INSTALLATION

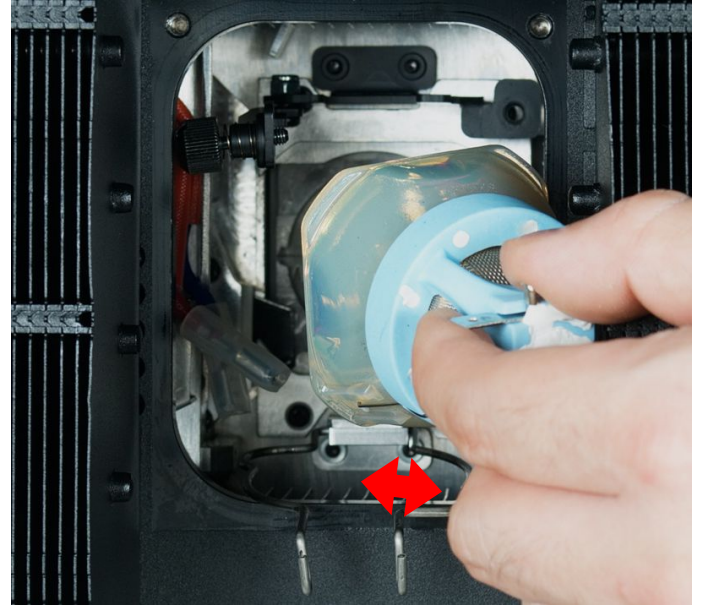
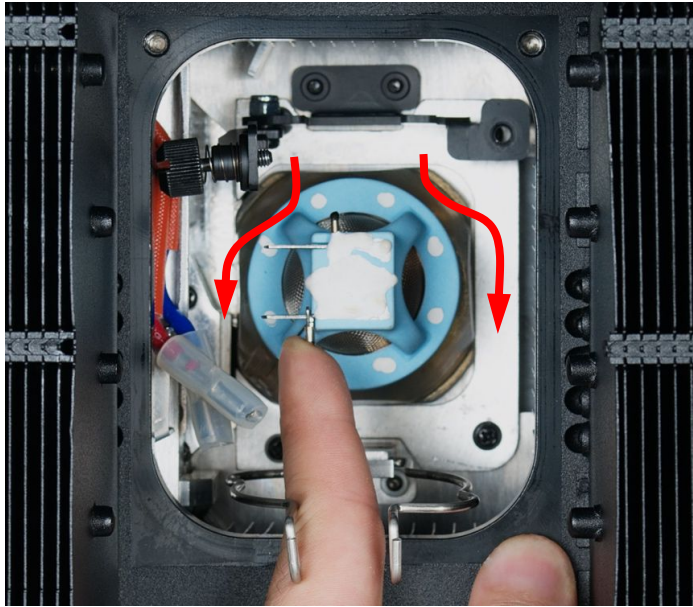

9. Swing the lamp retaining clip out, then carefully remove the lamp.



WARNING! LAMP MAY BE HOT. USE CAUTION WHEN TOUCHING LAMP WITH BARE HANDS.

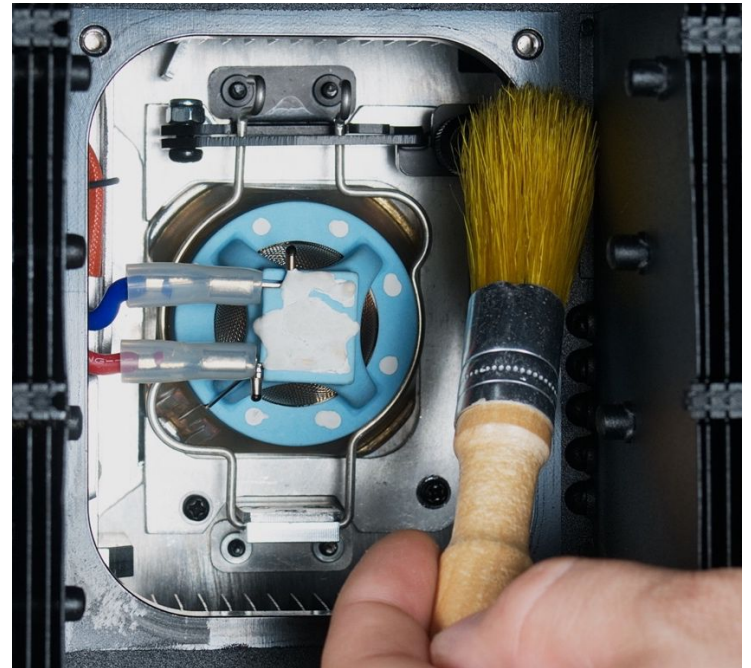
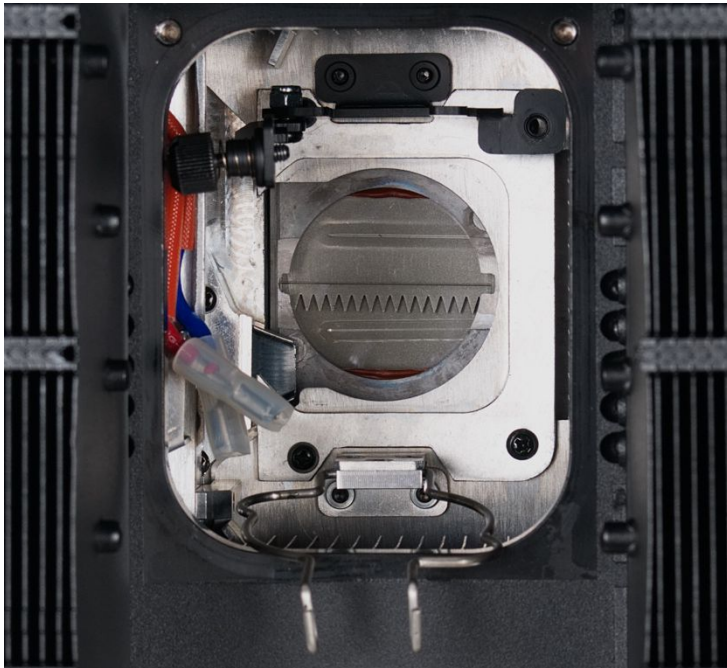

10. Carefully install the new lamp then follow the removal instruction steps in reverse order.
NOTE: Brush away any debris using a nonabrasive brush before replacing the heatsink.

LAMP INSTALLATION



GASKET INSPECTION

CAREFULLY REMOVE ANY DEBRIS FOUND ON GASKET AND SCREW HOLES OF THE HEATSINK MODULE USING A NONABRASIVE BRUSH BEFORE INSTALLING!

CAREFULLY INSPECT HEATSINK GASKET FOR SIGNS OF WEAR SUCH AS CRACKING OR HARDENING, DEFORMITIES, OR ALIGNMENT ISSUES BEFORE INSTALLING!

ITEMS ABOVE CAN IMPEDE THE IP65 INTEGRITY AND/OR CAUSE INTERNAL DAMAGE. CONTACT ELATION SERVICE REGARDING GASKET REPLACEMENT IF NEEDED.

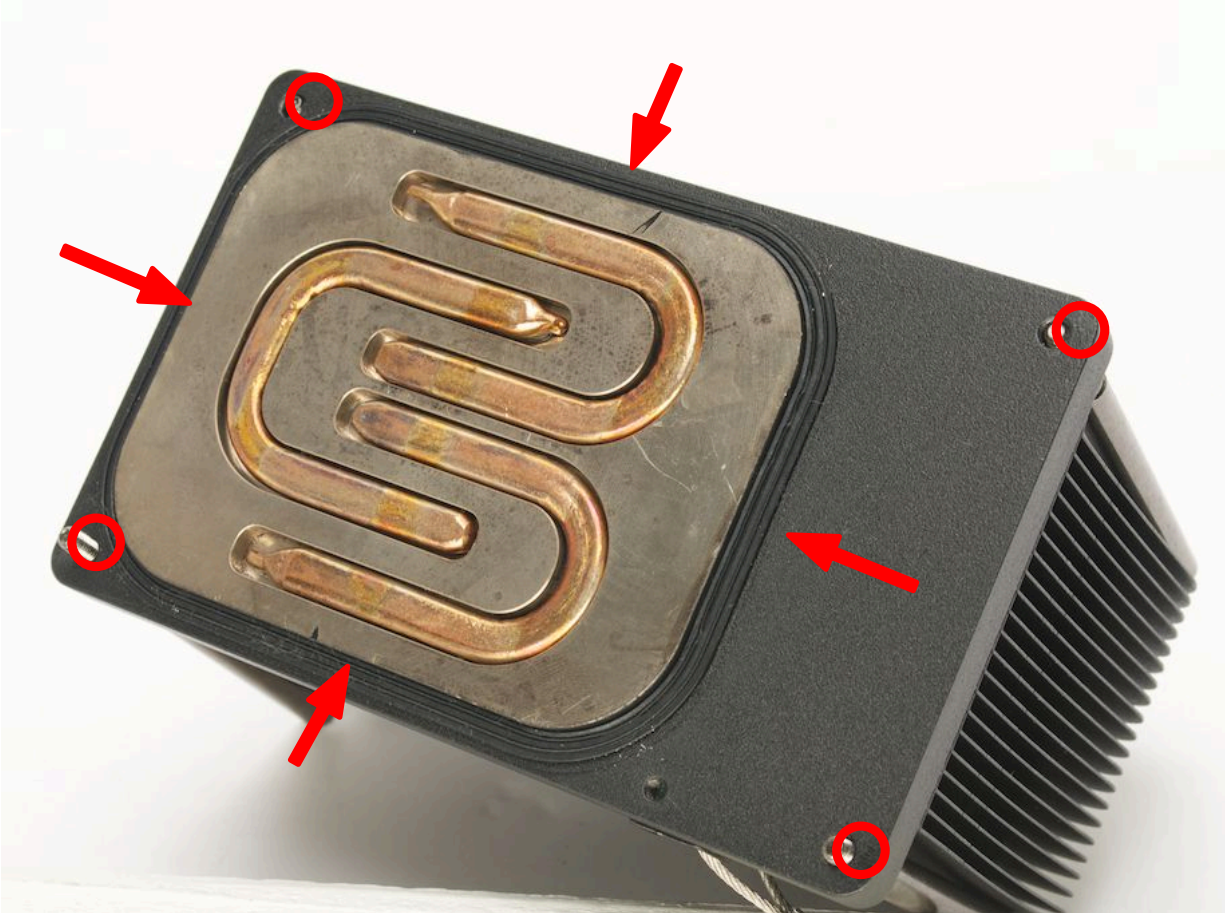

LAMP INSTALLATION

TORQUE SETTINGS FOR SCREWS



HEATSINK MODULE SCREWS MUST BE TIGHTENED WITH A TORQUE WRENCH.



The (4x) hex-head screws holding the heatsink module **MUST** be tightened with a torque-wrench (not included).

TORQUE SETTING = 11 lbf-in. (12.7kgf-cm) *

*** lbf-in = Pound Force Inches | kgf-cm = Kilogram Force Centimeters**



CAUTION! DO NOT OVER TORQUE SCREWS AS THIS CAN CAUSE LEAKAGE ISSUES!

LAMP INSTALLATION

IP TESTING



TO CONFIRM THE IP65 INTEGRITY AFTER A LAMP REPLACEMENT, TEST FIXTURE USING THE ELATION IP TESTER. CONTACT ELATION SERVICE FOR MORE DETAILS.



CAUTION! THE USE OF PROTECTIVE GLOVES AND SAFETY GOGGLES IS STRONGLY RECOMMENDED WHILE PERFORMING THE IP PRESSURE TEST! AVOID PLACING YOUR FACE, EYES, HANDS, ETC IN CLOSE PROXIMITY TO THE FIXTURE'S LENS WHILE PERFORMING THE TEST!

IP TESTING PARAMETERS			
Test	Minimum Pressure	Maximum Pressure	Steady/Hold Time
Vacuum	-4.35 psi (-30.00 Kpa)	-5.08 psi (-35.00 Kpa)	10 sec
Pressure	3.62 psi (25.00 Kpa)	4.35 psi (30.00 Kpa)	10 sec



GOBO INSTALLATION



WARNING! GOBO REPLACEMENT SHOULD ONLY BE DONE BY A TRAINED TECHNICIAN.

1. Turn OFF power and allow approximately 60 minutes for the fixture to cool down.



2. Place the head in an upright vertical position and engage both the **PAN** and **TILT** locks for added stability while replacing the gobo.



3. Remove (12x) 3mm hex-head screws (6x per panel) to remove both center panels.

GOBO INSTALLATION

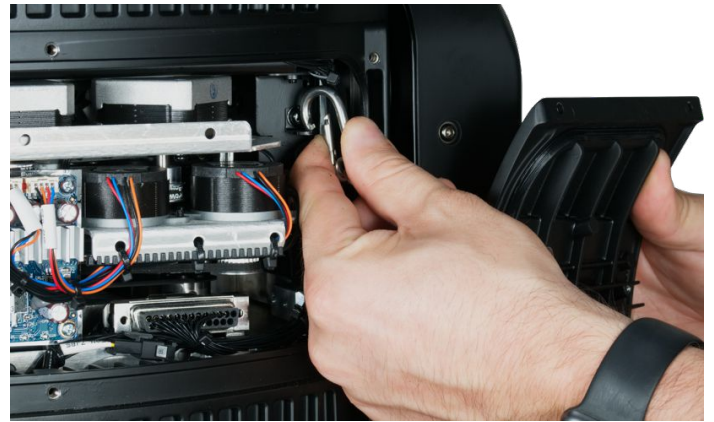
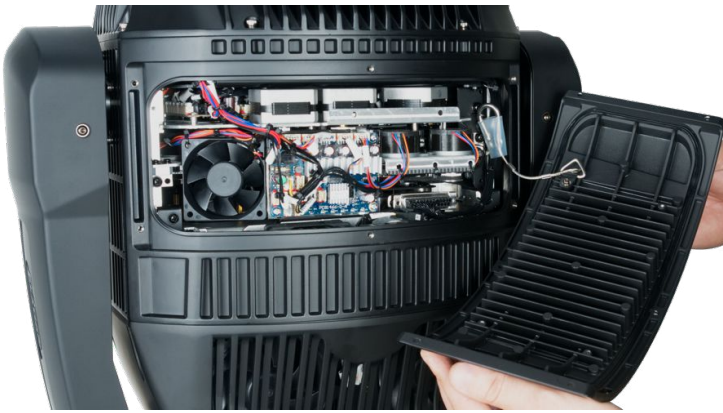

4. Unclip the panel safety cable one side of the head.

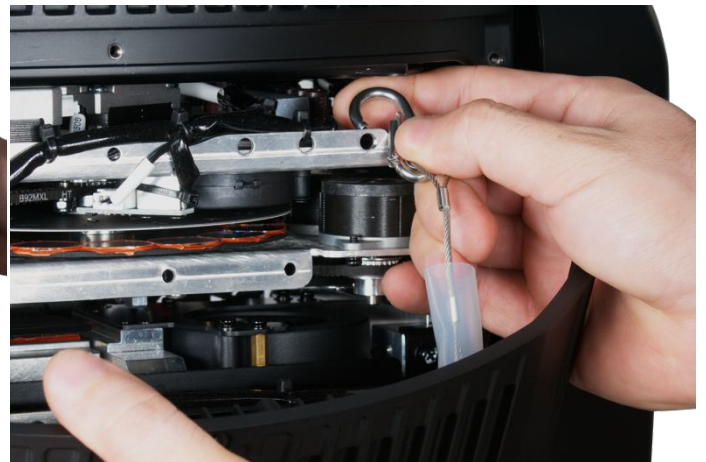

5. Unclip the panel safety cable on the opposite side of the head.

GOBO INSTALLATION

6. Cut the plastic cable-ties holding wires and disconnect connectors attached to the effect module.

6a

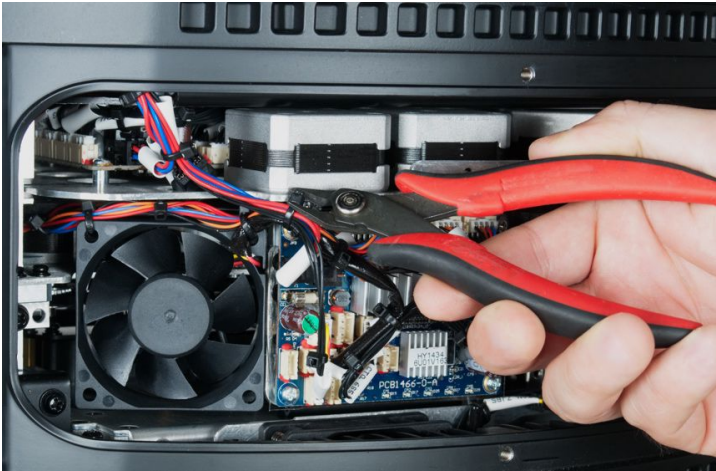

6b

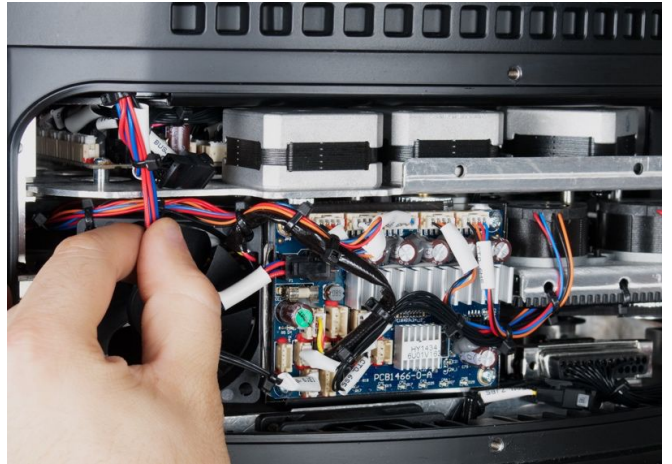

6c

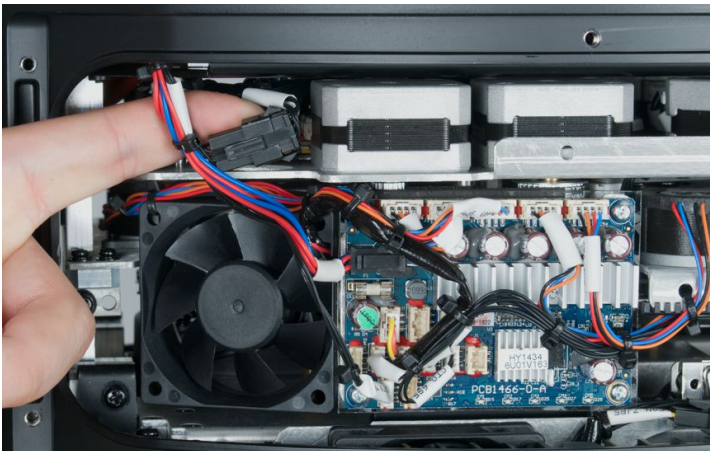

6d

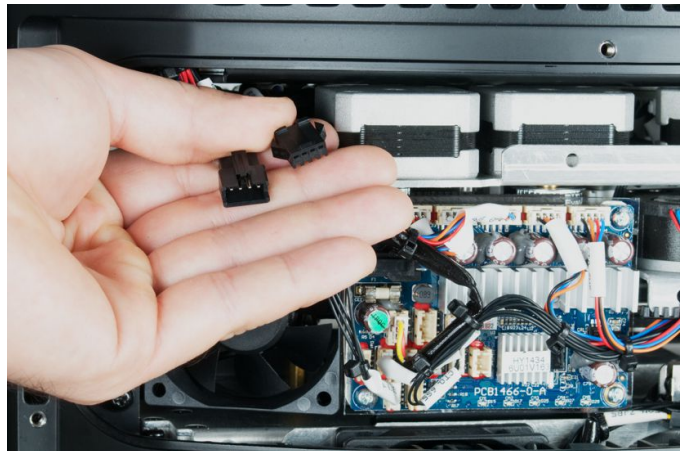

6e

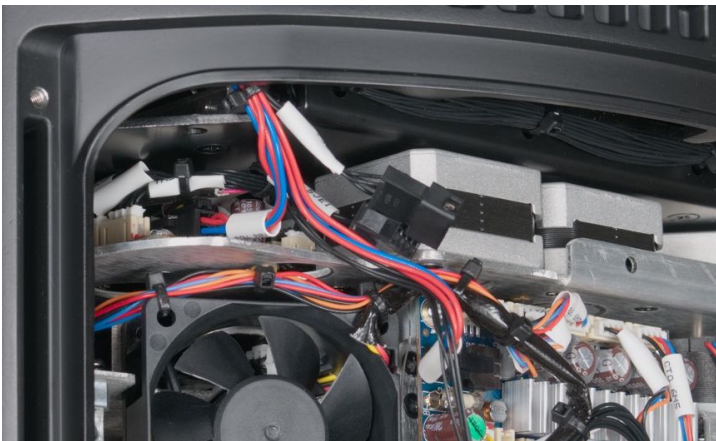

6f



GOBO INSTALLATION

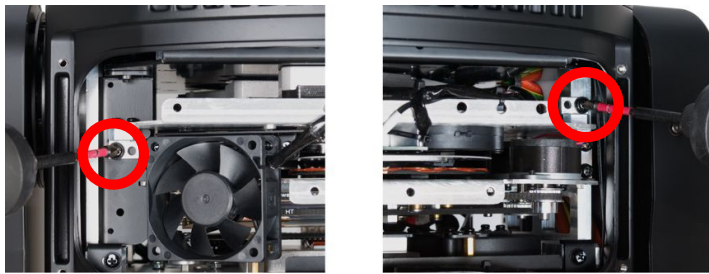

7. Remove (2x) #2 Philips screws securing effect module.

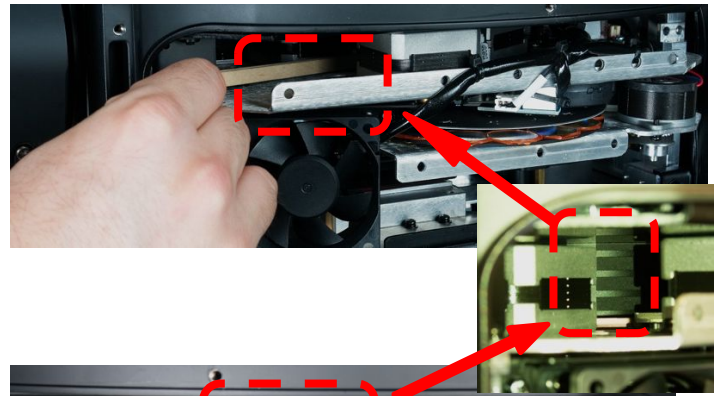

8. Gently lift GOBO lens away from effect module.



9. Carefully remove the effect module from fixture.



10. Place the effect module on firm clean surface and locate GOBO to replace.



11. Carefully lift the GOBO Holder up and out from the GOBO wheel using small needle nose pliers.



CAUTION! DO NOT SCRATCH GOBO AND HOLDER WHEN REPLACING!

GOBO INSTALLATION



12. Carefully remove retaining spring.  **CAUTION! DO NOT SCRATCH GOBO OR GOBO HOLDER!**

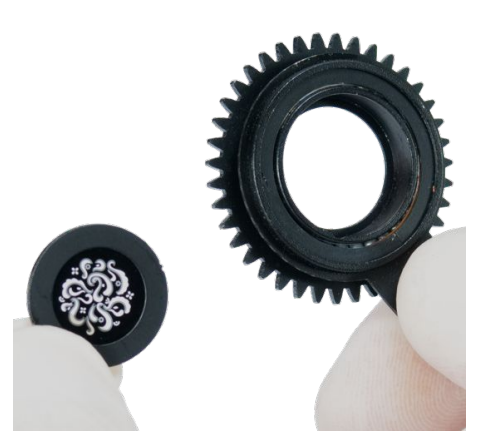

13. Carefully separate the GOBO disc from the GOBO Holder.

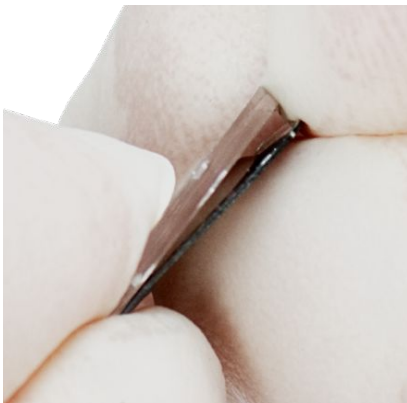

14. Carefully remove the retaining ring washer attached to the GOBO.



**SAVE RETAINING RING WASHER FOR USE WITH THE NEW REPLACEMENT GOBO!
RETAINING RING MUST BE USED IN ORDER TO PREVENT GOBO BURNING!**

15. Carefully replace the GOBO and GOBO Holder following the instruction steps in reverse order.
NOTE: Brush away any debris using a nonabrasive brush before installing the effect module.

GOBO INSTALLATION



GASKET INSPECTION

CAREFULLY REMOVE ANY DEBRIS FOUND ON GASKET AND SCREW HOLES OF BOTH CENTER PANELS USING A NONABRASIVE BRUSH BEFORE INSTALLING!

CAREFULLY INSPECT GASKETS FOR SIGNS OF WEAR SUCH AS CRACKING OR HARDENING, DEFORMITIES, OR ALIGNMENT ISSUES BEFORE INSTALLING!

ITEMS ABOVE CAN IMPEDE THE IP65 INTEGRITY AND/OR CAUSE INTERNAL DAMAGE.

CONTACT ELATION SERVICE REGARDING GASKET REPLACEMENT IF NEEDED.

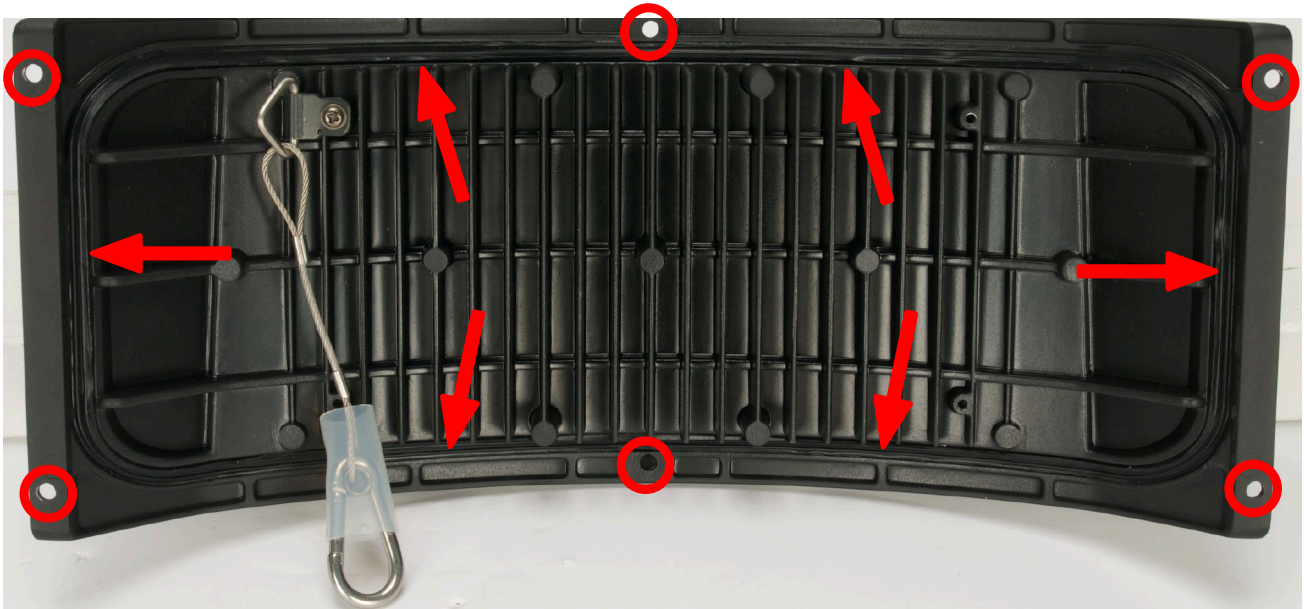

GOBO INSTALLATION

TORQUE SETTINGS FOR SCREWS



PANEL SCREWS MUST BE TIGHTENED WITH A TORQUE WRENCH.



The (12x) hex-head screws that secure the panels MUST be tightened with a torque wrench (not included).

TORQUE SETTING = 11 lbf-in. (12.7kgf-cm) *

*** lbf-in = Pound Force Inches | kgf-cm = Kilogram Force Centimeters**



CAUTION! DO NOT OVER TORQUE SCREWS AS THIS CAN CAUSE LEAKAGE ISSUES! TO CONFIRM THE IP65 INTEGRITY AFTER A GOBO REPLACEMENT, TEST FIXTURE USING THE ELATION IP TESTER. CONTACT ELATION SERVICE FOR MORE DETAILS.



GOBO INSTALLATION

ROTATING GOBO SPECIFICATIONS

* * * IMPORTANT NOTICE REGARDING CUSTOM GOBOS * * *

Due to the extreme high temperature optical system, which can reach up to 842°F (450°C), special **BOROFLOAT** glass material and design requirements are required. Due to varying gobo manufacturing processes and tolerances, it is highly recommended to provide a gobo sample from the fixture to the custom gobo vendor for accurate sizing. Extended testing of custom gobo designs is highly recommended prior to using.

PLEASE CONTACT ELATION CUSTOMER SUPPORT FOR FURTHER INFORMATION

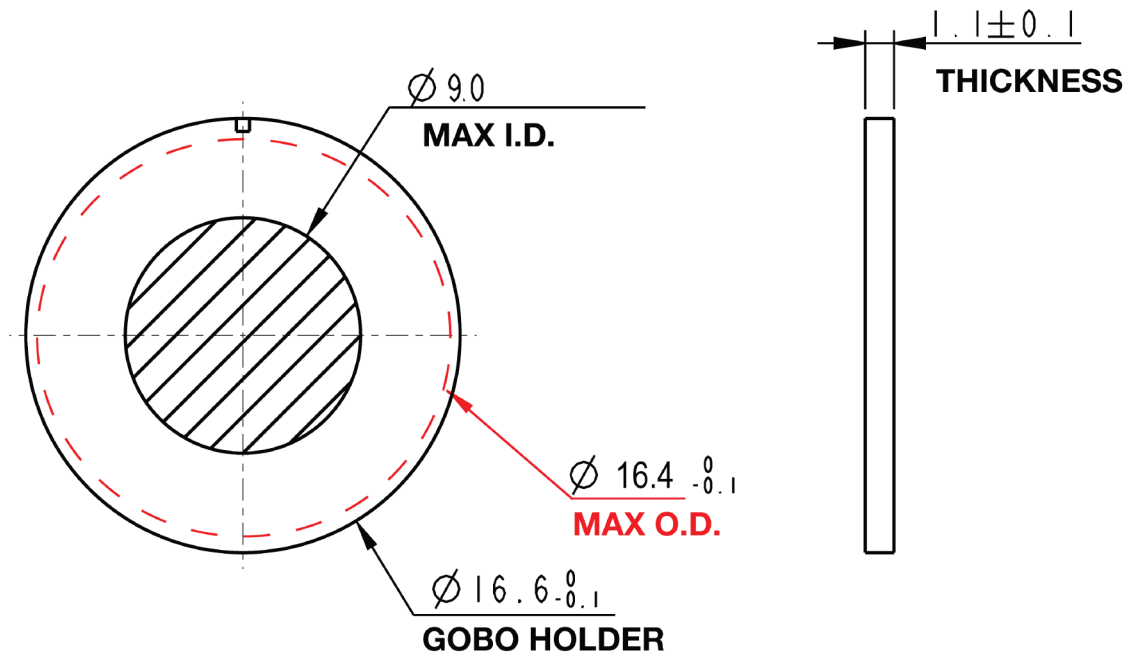

O.D. (Max. Outer Diameter)	$\phi 16.4\text{mm}$
I.D. (Max. Image Diameter)	$\phi 9\text{mm}$
Gobo Holder Diameter	$\phi 16.6\text{mm}$
Thickness	$1.1\text{mm} \pm 0.1\text{mm}$
Material	BOROFLOAT GLASS

GOBO INSTALLATION

CUSTOM GOBO DESIGN GUIDELINES

*** * * IMPORTANT NOTICE REGARDING CUSTOM GOBO DESIGNS* * ***

Full Color / Solid Area custom gobo designs are **NOT RECOMMENDED** due to the extreme high temperature optical system which can reach up to **842°F (450°C)**.

Custom gobo designs as illustrated below can burn during extended use periods.

PLEASE CONTACT ELATION CUSTOMER SUPPORT FOR FURTHER INFORMATION

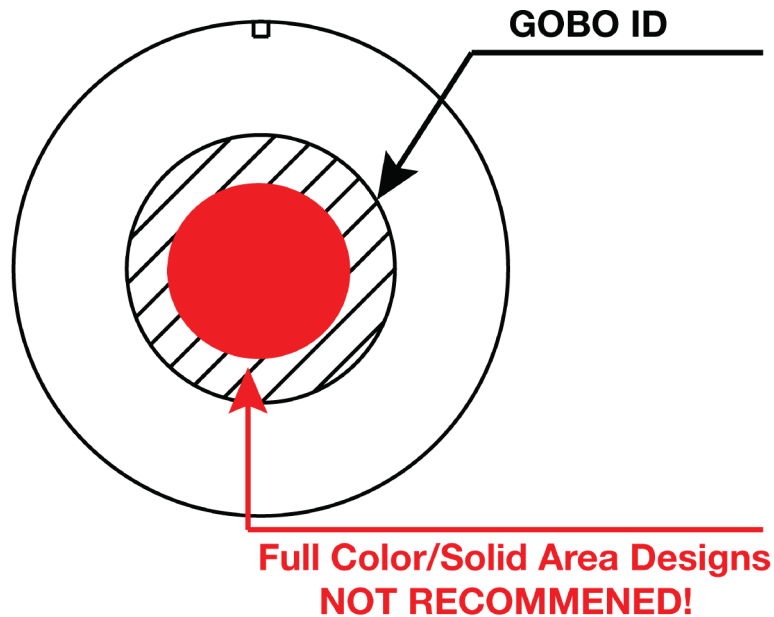

FIXTURE INSTALLATION



FLAMMABLE MATERIAL WARNING

Keep fixture at least 5.0 feet (1.5m) away from any flammable materials, decorations, pyrotechnics, etc.



ELECTRICAL CONNECTIONS

A qualified electrician should be used for all electrical connections and/or installations.



MINIMUM DISTANCE TO OBJECTS/SURFACES
MUST BE 40 FEET (12 METERS)



MAXIMUM TEMPERATURE OF EXTERNAL SURFACE
212° F (100°C)

DO NOT INSTALL THE FIXTURE IF YOU ARE NOT QUALIFIED TO DO SO!

Fixture **MUST** be installed following all local, national, and country commercial electrical and construction codes and regulations. Before rigging/mounting the fixture to any metal truss/structure or placing the fixture on any surface, a professional equipment installer **MUST** be consulted to determine if the metal truss/structure or surface is properly certified to safely hold the combined weight of the fixture, clamps, cables, and accessories.

Overhead fixture installation must always be secured with a secondary safety attachment, such as an appropriately rated safety cable that meets all local, national, and country codes and regulations.

Fixture ambient operating temperature range is **-4° to 113°F. (-20° to 45°C)**

Do not use this fixture outside this temperature range.

Fixture should be installed in areas outside walking paths, seating areas, or away from areas where unauthorized personnel might reach the fixture by hand.

NEVER stand directly below the fixture when rigging, removing, or servicing.

Allow approximately 15 minutes for the fixture to cool down before serving.

FIXTURE INSTALLATION

CLAMP INSTALLATION

The fixture can be attached to a metal truss/structure using. When mounting this fixture to truss be sure to secure (2) appropriately rated clamps (not included) to the (2) **Omega Brackets (included)** Be sure to attach the **Safety Cable (not included)** to the fixture using the safety cable rigging point integrated into the bottom of the fixture. (See image below)

SAFETY CABLE RIGGING POINT

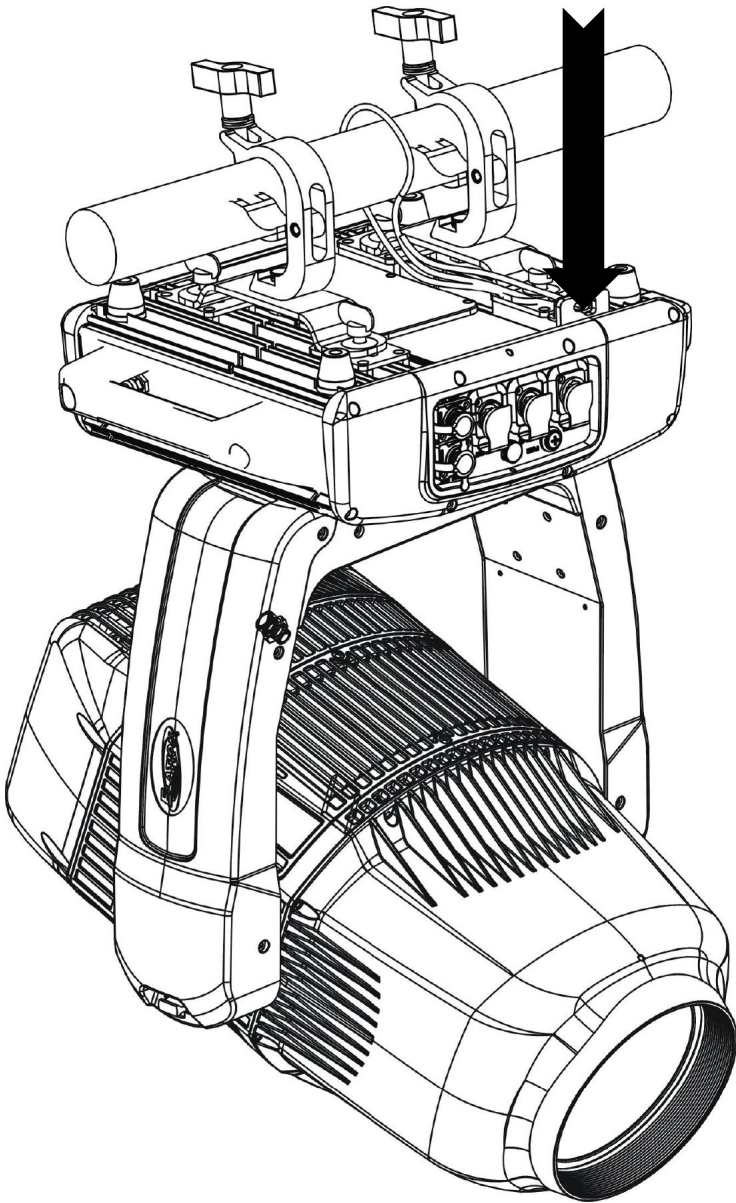

SAFETY CABLE

ALWAYS ATTACH A SAFETY CABLE
WHENEVER INSTALLING THIS DEVICE
IN A SUSPENDED ENVIRONMENT TO
ENSURE THE FIXTURE WILL NOT DROP
IF THE CLAMP FAILS.

FIXTURE INSTALLATION

OVERHEAD RIGGING

Overhead rigging requires extensive experience, including amongst others calculating working load limits, installation material being used, and periodic safety inspection of all installation material and the fixture. If you lack these qualifications, do not attempt the installation yourself. Improper installation can result in bodily injury.

Fixture is fully operational in the specific mounting positions illustrated below.

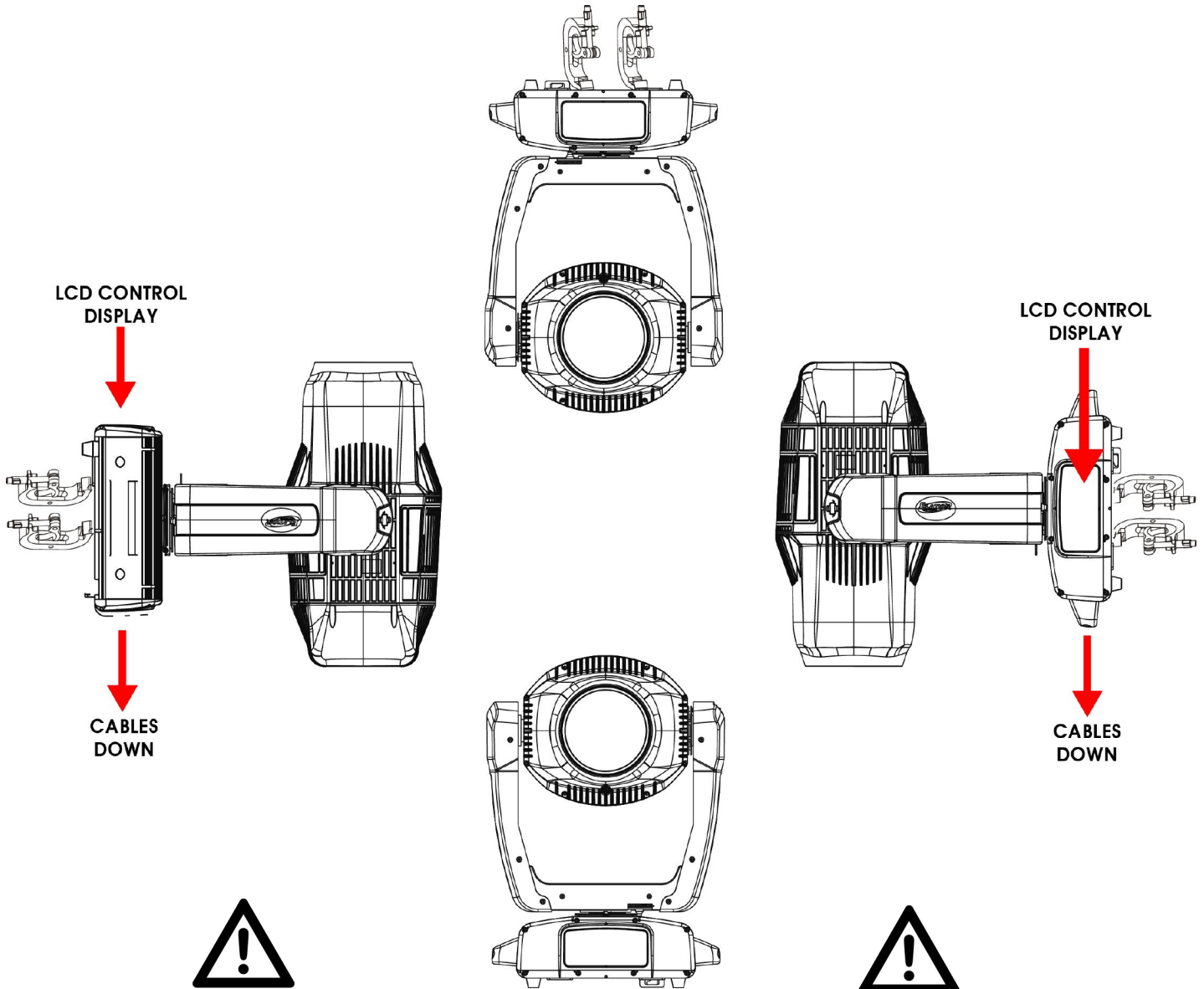

*SIDE MOUNTING

TO MAINTAIN IP65 RATING INTEGRITY, FIXTURE MUST BE INSTALLED WITH CABLES FACING DOWN TOWARDS THE GROUND AT ALL TIMES. WATER MUST EASILY RUN OFF AND NOT COLLECT AROUND CABLE CONNECTIONS.

*SAFETY CABLE

ALWAYS ATTACH A SAFETY CABLE WHENEVER INSTALLING THIS FIXTURE IN A SUSPENDED ENVIRONMENT TO ENSURE THE FIXTURE WILL NOT DROP IF THE CLAMP FAILS.

FIXTURE INSTALLATION

CONNECTIONS



ENSURE ALL CONNECTIONS AND END CAPS ARE PROPERLY SEALED WITH A DIELECTRIC GREASE (AVAILABLE AT MOST ELECTRICAL SUPPLIERS) TO PREVENT WATER CORROSION AND/OR ELECTRICAL SHORT CIRCUITE.



TO MAINTAIN IP65 RATING INTEGRITY, AND PREVENT WATER FROM ENTERING THE FIXTURE, ALL UNUSED CONNECTION RUBBER CAPS MUST BE SEALED.

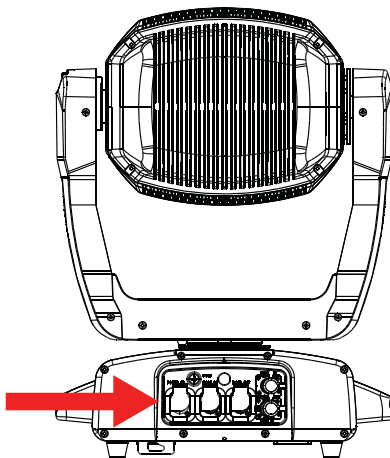

INCLUDED RJ45 DATA CABLE



THE INCLUDED RJ45 DATA CABLE IS FOR FIXTURE-TO-FIXTURE INTERCONNECT ONLY! THE RJ45 CABLE CONNECTORS MAY NOT BE COMPATIBLE WITH OTHER RJ45/ETHERCON TYPE CONNECTORS.

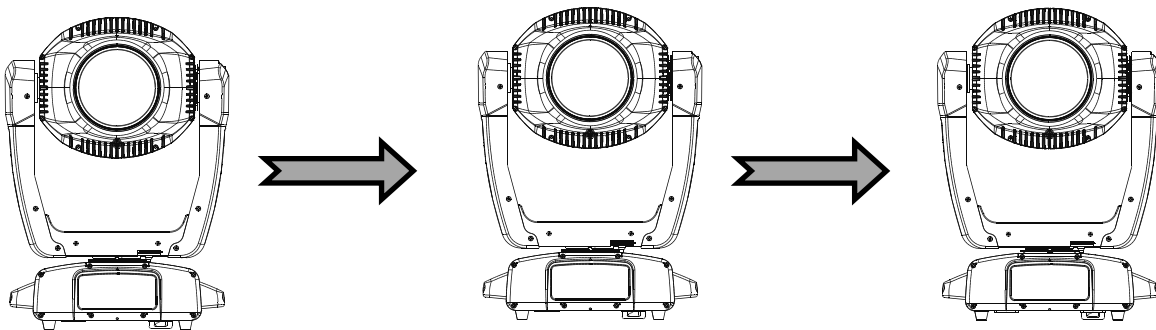

FIXTURE INSTALLATION

POTENTIAL INTERNAL FIXTURE DAMAGE FROM EXTERNAL SOURCES OF LIGHT BEAMS

External sources of light beams from direct sunlight, lighting moving head fixtures, and lasers, which are focused directly on the exterior housing and/or penetrate the front lens opening of ELATION lighting fixtures, can cause severe internal damage including burning to optics, dichroic color filters, glass and metal gobos, prisms, animation wheels, frost filters, iris, shutters, motors, belts, wiring, discharge lamps, and LEDs.

This issue is not specific only to ELATION lighting fixtures, it is a common issue with lighting fixtures from all manufacturers. Although there is no true way to fully prevent this issue from happening, the guidelines below can prevent any potential damage from occurring if followed. Contact ELATION Service for more details.

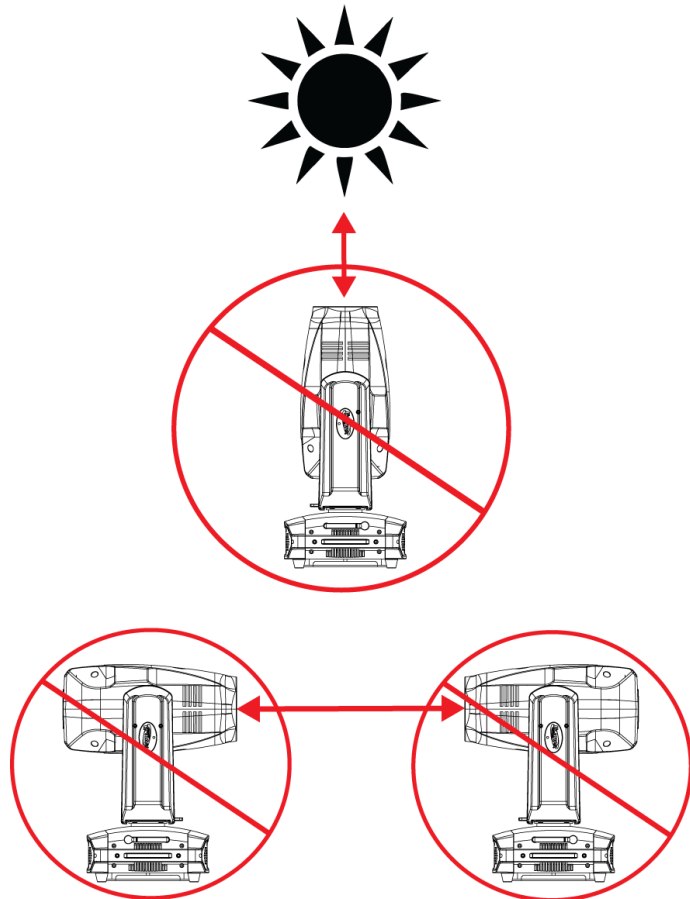

DO NOT EXPOSE THE FIXTURE AND/OR FRONT LENS OPENING TO LIGHT BEAMS FROM DIRECT SUNLIGHT, OTHER LIGHTING MOVING HEAD FIXTURES, AND LASERS WHILE UNPACKING, INSTALLATION, USE, AND EXTENDED IDLE TIMES OUTDOORS. DO NOT FOCUS A LIGHT BEAM FROM ONE LIGHTING FIXTURE DIRECTLY TOWARDS ANOTHER.

SUN PROTECTION MODE / HIBERNATION MODE

This state can be set via DMX, or will go into this state after 3 minutes without a DMX signal.

When the sun protection is activated, the pan-and-tilt function of the moving-head will position the lens away from direct sunlight, or other high intensity light source, to protect the internal belts, electronics etc. from burn damage.

When the unit is in the 'sun protection state', it uses its accelerometer sensors (X-Y-Z) (only present on discharge units and IP units) to position the front lens downwards, even when

the unit(s) will be moved from its position. This will keep on changing the position of the head.

Note that 'manual mode' overrides the 'sun-protection mode'.

The hibernation function is an existing feature that puts the unit into a 'sleep state' to save power (this is a state where only the electronics remain on, and all other functions are turned off, functions such as motors lamps etc). This state is automatically activated when no DMX signal is present for the set time (1-99min or off).

REMOTE DEVICE MANAGEMENT (RDM)

NOTE: For RDM to work properly, RDM enabled equipment must be used through-out the entire system, including DMX data splitters and wireless systems.

Remote Device Management (RDM) is a protocol that sits on top of the DMX512 data standard for lighting, allowing the DMX systems of the fixtures to be modified and monitored remotely. This protocol is ideal for instances in which a unit is installed in a location that is not easily accessible.

With RDM, the DMX512 system becomes bi-directional, allowing a compatible RDM enabled controller to send out a signal to devices on the wire, as well as allowing the fixture to respond (known as a GET command). The controller can then use its SET command to modify settings that would typically have to be changed or viewed directly via the unit's display screen, including the DMX Address, DMX Channel Mode, and Temperature Sensors.

FIXTURE RDM INFORMATION:

RDM Code	RDM Device ID	Device Model ID	Personality ID
0x59A	Open	1434	Open

Please be aware that not all RDM devices support all RDM features, and therefore it is important to check beforehand to ensure that the equipment that you are considering includes all the features that you require.

The following parameters are accessible in RDM on this device:

Sensor Definition
Sensor Value
Device Model Description
Manufacturer Label
Device Label
DMX Personality
DMX Personality Description
Device Hours
Lamp Hours
Lamp State
Pan Invert
Tilt Invert
Display Invert

SYSTEM MENU

The fixture includes an easy to navigate system menu control panel display where all necessary setting adjustments are made. (See image below) During normal operation, pressing **MODE/ESC** button once will access the fixture's main menu. Once in the main menu you can navigate through the different functions and access the sub-menus with the **UP, DOWN, RIGHT, and LEFT** buttons. Once you reach a field that requires adjusting, press the **ENTER** button to activate that field and use the **UP** and **DOWN** buttons to adjust the field. Pressing the **ENTER** button once more will confirm your setting. You may exit the main menu at any time without making any adjustments by pressing the **MODE/ESC** button.

NOTE: To access the LCD Menu Control Display via the internal battery, press and hold the **MODE/ESC** button for 10 seconds. The LCD Menu Control Display will shut **OFF** automatically about 60 seconds from the last button press.



AN ELATION E-LOADER III CAN BE USED TO UPDATE THE FIXTURE TO THE LATEST SOFTWARE. TO ORDER THIS DEVICE, PLEASE CONTACT ELATION SUPPORT FOR FURTHER DETAILS.

ELATION SERVICE USA - Monday - Friday 8:00am to 4:30pm PST
323-582-3322 | Fax 323-832-9142 | support@elationlighting.com

ELATION SERVICE EUROPE - Monday - Friday 08:30 to 17:00 CET
+31 45 546 85 63 | Fax +31 45 546 85 96 | support@elationlighting.eu

SYSTEM MENU

Features are subject to change without any prior written notice.

*Rotation direction (Clockwise or Counterclockwise) of effects depends on orientation of the fixture head and Pan/Tilt settings.

MAIN MENU	SUB MENU	OPTIONS / VALUES (Default Settings in BOLD)		DESCRIPTION
FUNCTION	Set Dmx Address	A001~AXXX		DMX Address Setting
	Dmx Value	PAN.....		DMX Value Display
	Secondary Mode	Secondary1, Secondary2, Secondary3		Secondary Setting
	Auto Program	Primary / Alone		Auto Program
INFORMATION	Time Information	Current Time	XXXX (Hours)	Fixture Run Time From Power ON
		Total Run Time	XXXX (Hours)	Fixture Total Run Time
		Last Run Time	XXXX (Hours)	Fixture Last Run Time
		Lamp Hours	XXXX (Hours)	Lamp Running Time
		Lamp Off Time	XXXX (Hours)	Lamp Off Time
		LastRun Password	Password= 038	(PSWD Required)
		Clear Last Run	ON / OFF	Clear Fixture Last Run Time
		LampTime Password	Password= 038	(PSWD Required)
	Temperature Info	Head Temperature	XXX C° / F°	Temperature in Fixture Head
		LAMP Temperature	XXX C° / F°	Temperature of LAMP
		Base Temperature	XXX C° / F°	Temperature in Fixture Base
	Humidity Info	Base Humidity	XXX%RH	Humidity In Fixture Base
		Head Humidity	XXX%RH	Humidity in Fixture Head
	Ethernet IP	XXX . XXX . XXX . XXX XXX . XXX . XXX . XXX	Displays Fixture Ethernet Address	
	Fan Info	1U_FAN1....	RPM Speeds of Fans	
	Encode Info	PAN ENCODE:, TILT ENCODE:...		
	Software Version	≥VX.X.X	Software Version	
Error Info	Error Record 1 ~ Error Record 10	Fixture Last 10 Error Codes		
LAMP CONTROL	Lamp ON/OFF	ON/OFF	Lamp ON/OFF	
	Automatic ON	ON/OFF	Lamp ON/OFF when Power ON	
	Lamp ON via DMX	ON/OFF	Lamp ON via DMX	
	Lamp OFF via DMX	ON/OFF	Lamp OFF via DMX	
	MaxOnatHumidity	20~100%RH, 70%RH	Fixture Restart at Humidity	

SYSTEM MENU

Features are subject to change without any prior written notice.

*Rotation direction (Clockwise or Counterclockwise) of effects depends on orientation of the fixture head and Pan/Tilt settings.

MAIN MENU	SUB MENU	OPTIONS / VALUES (Default Settings in BOLD)		DESCRIPTION
PERWSONALITY	Status Settings	Address via DMX	ON/OFF	Address Via DMX
		No DMX Status	SunProt/Close/ Hold /Auto	Fixture State When NO DMX Signal
		Pan Reverse	ON/ OFF	Pan Reverse Movement
		Tilt Reverse	ON/ OFF	Tilt Reverse Movement
		Pan Degree	630/ 540	Pan Degree Select
		Feedback	ON/OFF	Movement Feedback
		Movement Speed	High Speed NormalSpeed SlowSpeed	Select Movement Speed
		CMY Speed	Normal / Fast	
		FocusZoom Speed	High Speed NormalSpeed	
		Idle Position	ON/OFF	Idle Position Enable
		Hibernation	OFF, 01M~99M, 15M	Stand By Mode
		FollowSpot Mode	ON/ OFF	Manual Scan Mode (hide menu)
	Service Setting	Password	Password= 050	Service Password
		Clear Error Info	ON/ OFF	Clear Error Info (PSWD Required)
		Clear Error code	ON/ OFF	Clear Error Info (PSWD Required)
		DFLT Pow. LampOn	ON/OFF	Set Default Lamp Power State to ON
		DFLT Pow. E-Fly On	ON/OFF	
	Display Setting	Shutoff Time	02~60m 05m	LCD Display Shut Off Time
		Display Reverse	ON/ OFF	LCD Display Reverse 180°
		Key Lock	ON/ OFF	LCD Control Panel Lock Out
	Temperature C/F	Celsius/Fahrenheit		Temperature Switch Between C°/ F°
	Initial Status	PAN=XXX, ...		Initial Effect Position
	Select Signal	E-FLY Off		Control via DMX ONLY
		DMX & E-FLY		Control via DMX and E-FLY
		E-FLY & OUT		Control via E-FLY and sends DMX Out
		Art-Net		Control via Art-Net Protocol
		sACN		Control via sACN Protocol
	Ethernet IP	XXX.XXX.XXX.XXX		Set Fixture IP Address
	Ethernet Mask IP	XXX.XXX.XXX.XXX		Set Fixture Subnet Mask Address
	Set Universe	000 - 65535		Set ArtNet Universe (Art-Net 4)
	Set E-FLY Chn	00 - 15		Set E-FLY Wireless Channel
	Dimming Curves	Standard, Linear, Square, Inverse Square, S-Square		
Reset Default	ON/ OFF	Password= 011	Restore Factory Settings (PSWD Required)	
RESET FUNCTION	Reset All			
	Reset Pan & Tilt			
	Reset Colors			
	Reset Gobos			
	Reset Shutter			
	Reset Others			
EFFECT ADJUST	Test Channel	PAN...		
	Manual Control	PAN = xxx, ...		
	Calibration	Calibrate Password = 050		
PAN = xxx, ...				

SYSTEM MENU

Features are subject to change without any prior written notice.

*Rotation direction (Clockwise or Counterclockwise) of effects depends on orientation of the fixture head and Pan/Tilt settings.

MAIN MENU	SUB MENU	OPTIONS / VALUES (Default Settings in BOLD)		DESCRIPTION		
USER MODE SET		Basic Mode				
		Standard Mode				
		Extended Mode				
		User Mode A				
		User Mode Blkl				
		User Mode C				
		Max Channel = xx				
EDIT PROGRAM	Select Program	PAN = CH01, ...		Edit using mode A, B, C		
		Auto Pro Part 1 = Program 1 - 10				
		Auto Pro Part 2 = Program 1 - 10				
	Edit Program	Program 1 - 10	Auto Pro Part 3 = Program 1 - 10		Choose to run an automated program	
			Basic Mode			
			Program Test			Test program
			Step 01 = SCxxx			Program start scene
	Edit Scenes	Edit Scene 001 - 250	Step 64 = SCxxx		Program end scene	
			Pan, Tilt, ...		Manual operation scene input	
			-- Fade Time --		Modify fade time manually	
-- Scene Time --			Modify scene time manually			
Input By Out			External console scene input			
Rec Controller	xx - xx			Automatically record scenes		

PERSONALITY - Status Settings - Address Via DMX

When ON, define the desired DMX address via an external controller.

NOTE: This process assumes the fixture DMX address is set to 001. If fixture DMX address is not at 001, you must adjust the channel numbers accordingly in order for this feature to work.

For example: if your fixture address is 010, then Channel 1 becomes Channel 10, Channel 2 becomes Channel 11, and Channel 3 becomes Channel 12.

1. Connect the fixture to the external controller and power ON.
2. Set the DMX value of **Channel 1** on the controller to (7).
3. Set the DMX value of **Channel 2** on the controller to (7) or (8).

When set to (7), the DMX address can be set between (1) and (255).

When set to (8), the DMX address can be set between (256) and (511).

4. Using **Channel 3** on the controller set the desired DMX address of the fixture.

Example 1: If the desired DMX address is 57, set **Channel 1** to a value of (7), set **Channel 2** to a value of (7), and then set **Channel 3** to a value of (57).

Example 2: If the desired DMX address is 420, set **Channel 1** to a value of (7), set **Channel 2** to a value of (8), and then set **Channel 3** to a value of (164). (256+164=420)

5. After setting **Channel 3** to the desired DMX address value, wait for approximately 20 seconds (some fixtures may require a longer time) for the fixture to complete the address reset function.

PERSONALITY - Reset Default (011)

ONLY QUALIFIED TECHNICIANS SHOULD PERFORM THIS FUNCTION.



NOTE: SAVED WHITE BALANCE IS ERASED AFTER A RESET IS PERFORMED.

This function restores all fixture settings to the factory default settings. The password is 011 and must be entered each time a reset is performed.

EFFECT ADJUST – Test Channel

Auto test each individual channel function independently from the DMX control board.

EFFECT ADJUST – Manual Control

Select and manually test and fine adjust each individual channel function

Independently from DMX control board. This function will center PAN and TILT motors and set dimmer to 100%. PAN and TILT functions will still operate if the fixture needs to be positioned to a flat clear surface. With the individual functions, you can focus the light on a flat surface (wall) and perform fine adjustments.

EFFECT ADJUST – Calibration



ONLY QUALIFIED TECHNICIANS SHOULD PERFORM THIS FUNCTION.

This function allows small adjustments to be made to the Pan, Tilt, and Zoom movements to compensate for wear or in the event a sensor has been knocked slightly out of place. Because improper use of this function can result in undesired operation this function has been password protected. The password is 050 and must be entered each time the calibration menu function is entered. Because calibration is an extremely delicate procedure, instructions on performing this action are left out of this manual. For a first-time calibrator, please contact our customer support team for step-by-step instructions.

E-FLY WIRELESS DMX SETUP



BEFORE SETTING THE WIRELESS CHANNEL ON ANY E-FLY FIXTURE, MAKE SURE THE SOURCE E-FLY WIRELESS DMX TRANSCEIVER DEVICE IS OFF. TO CONTROL FIXTURE WITH E-FLY WIRELESS DMX SIGNAL

1. Ensure the source **E-FLY** wireless DMX Transceiver device is powered **OFF**.
2. Power **ON** fixture and from the LCD control panel select **DMX & E-FLY** or **E-FLY & OUT** in the **Select Signal** sub menu of the **PERSONALITY** main system menu.
3. From the LCD control panel set the **E-FLY** wireless channel to the same wireless channel of the source **E-FLY** DMX Transceiver device in the **Set E-FLY Chn** sub menu of the **PERSONALITY** main system menu.

NOTE: Erratic fixture movement may occur if other **E-FLY** wireless DMX products are in use in the same area and are using the same **E-FLY** wireless channel. The fixture may immediately start to respond to the DMX wireless signal from another **E-FLY** wireless DMX Transceiver immediately when **E-FLY** is enabled. Make sure to know what **E-FLY** wireless channels are being used in the area where the fixture is being installed.

ELATION E-FLY WIRELESS TRANSCEIVER only has 0-14 wireless channels, NO CH 15.

4. Set fixture DMX address in the **Set Dmx Address** sub menu of the **FUNCTION** main system menu.
5. The **E-FLY** signal Indicator on the fixture LCD control display will illuminate **GREEN** if a successful wireless DMX connection has been made or illuminate **RED** for NO connection. If no connection is made, repeat steps 1-4 above.
6. Repeat this process for all **E-FLY** compatible fixtures in the E-FLY wireless network, making sure all fixtures are assigned the same **E-FLY** wireless channel.
7. After all fixtures in the **E-FLY** wireless network have been set to the same **E-FLY** wireless channel and powered ON, now power ON the source **E-FLY** DMX Transceiver device.
8. Test all fixtures connected to the **E-FLY** wireless network to confirm proper functionality.

E-FLY WIRELESS DMX SETUP

Wireless DMX signal can penetrate walls, glass, metal, and most objects. However, there are many factors that can affect and/or interrupt the wireless DMX signal, one of which is people. Therefore, it is highly recommended to position the wireless antenna a minimum of 9.8 ft. (3m) above audiences and/or above ground level. Careful planning and testing of the selected installation location is critical to ensure optimum and reliable wireless DMX operation.

**9.8 ft (3m)
Above Ground**

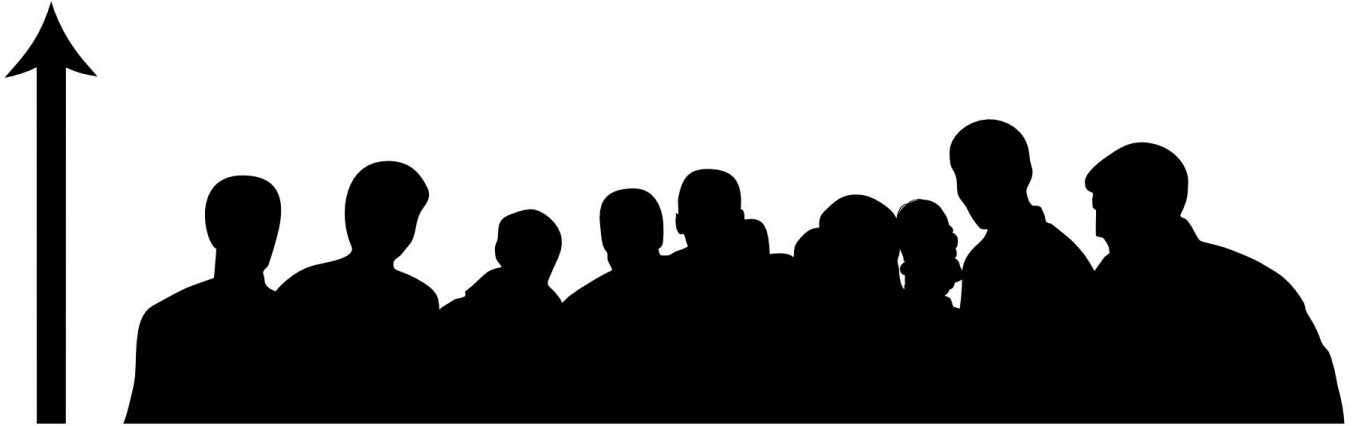

DMX CHANNEL FUNCTIONS AND VALUES

DMX Channel Values / Functions (26, 24, 37 DMX Channels)				
Supports Software Versions: $\geq 1.8.0$				
Features subject to change without any prior written notice.				
*Rotation direction (Clockwise or Counterclockwise) of effects depends on orientation of the fixture head and Pan/Tilt settings.				
MODE / CHANNEL			VALUE	FUNCTION
BASIC	STAND	EXTEND		
1	1	1		PAN Movement 8bit:
			0-255	Pan Movement
	2	2		Pan Fine 16bit
			0-255	Fine control of Pan movement
2	3	3		TILT Movement 8bit :
			0-255	Tilt Movement
	4	4		Tilt Fine 16bit
			0-255	Fine control of Tilt movement
3	5	5		Cyan Color :
			0-255	Cyan (0-white, 255-100% Cyan)
		6		Cyan Color Fine:
			0-255	Cyan Fine
4	6	7		Magenta Color:
			0-255	Magenta (0-white, 255-100% magenta)
		8		Magenta Color Fine:
			0-255	Magenta Fine
5	7	9		Yellow Color:
			0-255	Yellow (0-white, 255-100% Yellow)
		10		Yellow Color Fine:
			0-255	Yellow Fine
6	8	11		CTO Color:
			0-255	CTO (0-white, 255-100% CTO)
		12		CTO Color Fine:
			0-255	CTO Fine
7	9	13		Color Wheel:
			0-15	Open / white
			16-23	Red
			24-31	Blue
			32-39	Green
			40-47	Yellow
			48-55	Purple
			56-63	Cyan
			64-71	Orange
			72-79	Pink
			80-87	Light Green
			88-95	Light Yellow
			96-103	Magenta
			104-111	CTB
			112-119	CTO
			120-127	V67
128-189	Clockwise scroll from fast to slow			
190-193	No rotation			
194-255	Counterclockwise scroll from slow to fast			

DMX CHANNEL FUNCTIONS AND VALUES

Supports Software Versions: $\geq 1.8.0$				
Features subject to change without any prior written notice.				
*Rotation direction (Clockwise or Counterclockwise) of effects depends on orientation of the fixture head and Pan/Tilt settings.				
MODE / CHANNEL			VALUE	FUNCTION
BASIC	STAND	EXTEND		
		14		Color Wheel Fine:
			0-255	Color Wheel colour change to any position Fine
8	10	15		Rotating gobos, cont. rotation:
			0-10	Beam open
			11-21	Spot open
			22-31	Rot. gobo 1
			32-41	Rot. gobo 2
			42-51	Rot. gobo 3
			52-61	Rot. gobo 4
			62-71	Rot. gobo 5
			72-81	Rot. gobo 6
			82-91	Rot. gobo 7
			92-101	Rot. gobo 8
			102-112	Rot. gobo 1 shake
			113-123	Rot. gobo 2 shake
			124-134	Rot. gobo 3 shake
			135-145	Rot. gobo 4 shake
			146-156	Rot. gobo 5 shake
			157-167	Rot. gobo 6 shake
			168-178	Rot. gobo 7 shake
			179-189	Rot. gobo 8 shake
			222-223	Reserved
			224-255	Counter clock-wise scroll from slow to fast
9	11	16		Rotating gobo index, rotating gobo rotation:
			0-127	Gobo indexing
			128-189	Clockwise rotation from fast to slow
			190-193	No rotation
			194-255	Counterclockwise rotation from slow to fast
		17		Rotating gobo indexing Fine
			0-255	Fine indexing

DMX CHANNEL FUNCTIONS AND VALUES

Supports Software Versions: $\geq 1.8.0$				
Features subject to change without any prior written notice.				
*Rotation direction (Clockwise or Counterclockwise) of effects depends on orientation of the fixture head and Pan/Tilt settings.				
MODE / CHANNEL			VALUE	FUNCTION
BASIC	STAND	EXTEND		
10	12	18		Fixed Gobos:
			0-7	Open/hole
			8-14	Gobo 1
			15-21	Gobo 2
			22-28	Gobo 3
			29-35	Gobo 4
			36-42	Gobo 5
			43-49	Gobo 6
			50-56	Gobo 7
			57-63	Gobo 8
			64-70	Gobo 9
			71-77	Gobo 10
			78-84	Gobo 11
			85-91	Gobo 12
			92-98	Gobo 13
			99-105	Gobo 14
			106-111	Gobo 1 shake slow to fast
			112-117	Gobo 2 shake slow to fast
			118-123	Gobo 3 shake slow to fast
			124-129	Gobo 4 shake slow to fast
			130-135	Gobo 5 shake slow to fast
			136-141	Gobo 6 shake slow to fast
			142-147	Gobo 7 shake slow to fast
			148-153	Gobo 8 shake slow to fast
			154-159	Gobo 9 shake slow to fast
			160-165	Gobo 10 shake slow to fast
			166-171	Gobo 11 shake slow to fast
			172-177	Gobo 12 shake slow to fast
		178-183	Gobo 13 shake slow to fast	
		184-189	Gobo 14 shake slow to fast	
190-221	Clockwise scroll from fast to slow			
222-223	No rotation			
224-255	Counterclockwise scroll from slow to fast			
		19		Fixed gobo indexing Fine
			0-255	Fixed gobo Fine indexing

DMX CHANNEL FUNCTIONS AND VALUES

Supports Software Versions: $\geq 1.8.0$				
Features subject to change without any prior written notice.				
*Rotation direction (Clockwise or Counterclockwise) of effects depends on orientation of the fixture head and Pan/Tilt settings.				
MODE / CHANNEL			VALUE	FUNCTION
BASIC	STAND	EXTEND		
11	13	20		Rotating prism, Prism / Gobo macros:
			0-31	Open position (hole)
			32-64	8 Prism
			65- 94	Line Prism
			95- 127	8/Line Prism
			128-135	Macro 1
			136-143	Macro 2
			144-151	Macro 3
			152-159	Macro 4
			160-167	Macro 5
			168-175	Macro 6
			176-183	Macro 7
			184-191	Macro 8
			192-199	Macro 9
			200-207	Macro 10
			208-215	Macro 11
			216-223	Macro 12
224-231	Macro 13			
232-239	Macro 14			
240-247	Macro 15			
248-255	Macro 16			
12	14	21		Rotating 8/Line prism:
			0-127	Prism indexing
			128-189	Clockwise rotation from fast to slow
			190-193	No rotation
		194-255	Counter clock-wise rotation from slow to fast	
		22		Rotating 8/Line prism indexing Fine
			0-255	Fine indexing
13	15	23		Focus:
			0-255	Continuous adjustment from near to far
		24		Focus Fine:
			0-255	Continuous adjustment Fine
14	16	25		Zoom:
			0-255	Zoom adjustment from small to big
		26		Zoom Fine:
			0-255	Zoom adjustment Fine

DMX CHANNEL FUNCTIONS AND VALUES

Supports Software Versions: $\geq 1.8.0$				
Features subject to change without any prior written notice.				
*Rotation direction (Clockwise or Counterclockwise) of effects depends on orientation of the fixture head and Pan/Tilt settings.				
MODE / CHANNEL			VALUE	FUNCTION
BASIC	STAND	EXTEND		
15	17	27		Auto Focus:
			0-50	Auto Focus Off
			51-150	15m
			151-255	20m
16	18	28		Auto Focus adjustment:
			0-255	Continuous adjustment
17	19	29		Shutter, strobe:
			0-31	Shutter closed
			32-63	No function (shutter open)
			64-95	Strobe effect slow to fast
			96-127	No function (shutter open)
			128-159	Pulse-effect in sequences
			160-191	No function (shutter open)
			192-223	Random strobe effect slow to fast
			224-255	No function (shutter open)
18	20	30		Dimmer intensity:
			0-255	Intensity 0 to 100%
		31		Fine Dimmer intensity:
			0-255	Dimmer intensity fine
19	21	32		Frost:
			0-127	Disable frost
			128-255	Enable frost
20	22	33		Animation wheel:
			0-7	Close
			8-127	Clockwise scroll from fast to slow
			128-135	No rotation
			136-255	Counterclockwise scroll from slow to fast
21	23	34		CMY Speed:
			0-255	Speed Max \rightarrow Min

DMX CHANNEL FUNCTIONS AND VALUES

Supports Software Versions: $\geq 1.8.0$				
Features subject to change without any prior written notice.				
*Rotation direction (Clockwise or Counterclockwise) of effects depends on orientation of the fixture head and Pan/Tilt settings.				
MODE / CHANNEL			VALUE	FUNCTION
BASIC	STAND	EXTEND		
22	24	35		CMY macros:
			0-31	OFF
			32-39	Macro1
			40-47	Macro2
			48-55	Macro3
			56-63	Macro4
			64-71	Macro5
			72-79	Macro6
			80-87	Macro7
			88-95	Macro8
			96-103	Macro9
			104-111	Macro10
			112-119	Macro11
			120-127	Macro12
			128-135	Macro13
			136-143	Macro14
			144-151	Macro15
			152-159	Macro16
			160-167	Macro17
			168-175	Macro18
			176-183	Macro19
			184-191	Macro20
			192-199	Macro21
			200-207	Macro22
208-215	Macro23			
216-223	Macro24			
224-231	Macro25			
232-239	Macro26			
240-247	Macro27			
248-255	Random CMY			
23	25	36		Speed Pan/Tilt movement:
			0-225	max to min speed
			226-235	blackout by movement
			236-245	blackout by all wheel changing
			246-248	Sun protection on
			249-251	Sun protection off
			252-253	Idle position on
254-255	Idle position off			

DMX CHANNEL FUNCTIONS AND VALUES

Supports Software Versions: $\geq 1.8.0$				
Features subject to change without any prior written notice.				
*Rotation direction (Clockwise or Counterclockwise) of effects depends on orientation of the fixture head and Pan/Tilt settings.				
MODE / CHANNEL			VALUE	FUNCTION
BASIC	STAND	EXTEND		
24	26	37		Control:
			0-19	color change normal
			20-29	color change to any position
			30-39	color & Fixed gobo change to any position
			40-59	Lamp on
			60-79	Lamp switch off
			80-84	All motor reset
			85-87	Scan motor reset
			88-90	Colors motor reset
			91-93	Gobo motor reset
			94-96	Shutter & Dimmer motor reset
			97-99	Other motor reset
			100-119	Internal program 1
			120-139	Internal program 2
			140-159	Internal program 3
			160-179	Internal program 4
			180-199	Internal program 5
			200-219	Internal program 6
			220-239	Internal program 7
			240-241	Dimming Standard
			242-243	Dimming Linear
			244-245	Dimming Square
			246-247	Dimming Inverse Square
			248-249	Dimming S-Curve
			250	Display Off
251	Display On			
252	CMY Normal			
253	CMY Fast (default)			
254	Hibernation Off			
255	Hibernation On			

ERROR CODES

When power is applied, the unit will automatically enter a **“Reset/Test”** mode. This mode brings all the internal motors to a home position. If there is an internal problem with one or more of the motors an error code will flash in the display in the form of **“XXEr”** where as XX will represent a function number. For example, when the display shows **“0Er”** it means there is some type of error with the Pan motor. If there are multiple errors during the start-up process, they will all flash in the display. For example: if the fixtures have errors on **Channel 1, 2, and 5** all at the same time, you will see the error message **“01Er”, “02Er”, and “05Er”** flash repeated 5 times.

If an error does occur during the initial start-up procedure the fixture will self-generate a second reset signal and try to realign all the motors and correct the errors. If the error persists after a second attempt a third attempt will be made. If after a third attempt all the errors have not been corrected the fixture will make the following determinations:

- **3 or More Errors** - The fixture cannot function properly with three or more errors therefore the fixture will place itself in a stand-by mode until subsequent repairs can be made.
- **Less Than 3 Errors** - The fixture has less than 3 errors; therefore, most other functions will work properly. The fixture will attempt to operate normally until the errors can be corrected by a technician. The errors in question will remain flashing in the display as a reminder of internal errors.



BALLAST ERROR NOTE

IF A BALLAST ERROR MESSAGE APPEARS, TURN THE LAMP OFF FOR 3-5 MINUTES TO RESET THE BALLAST. IF AFTER 5-MINUTES A BALLAST ERROR STILL APPEARS, TURN THE FIXTURE OFF TO RESET THE BALLAST. IF A BALLAST MESSAGE STILL APPEARS, PLEASE CONSULT ELATION CUSTOMER SUPPORT.

ERROR CODES

Error Codes are subject to change without any prior written notice.	
ERROR CODES	DESCRIPTION
PAN Er	The PAN movement is not located in the default position after the reset. This message will appear after a fixture reset if the magnetic-indexing circuit malfunctions (sensor failed or magnet is missing) or there is a motor failure (defective motor or a defective motor IC drive on the main PCB). This error may also be displayed if the head/yoke was blocked during a reset function.
TILT Er	The TILT movement is not located in the default position after the reset. This message will appear after a fixture reset if the magnetic-indexing circuit malfunctions (sensor failed or magnet is missing) or there is a motor failure (defective motor or defective motor IC drive on main PCB). This error may also be displayed if the head was blocked during a reset function.
Cyan Wheel Er	The Cyan Color Wheel is not located in the default position after the reset. This message will appear after the reset of the fixture reset if the magnetic-indexing circuit malfunctions (sensor failed or magnet is missing) or there is a stepper motor failure (defective motor or defective motor IC drive on main PCB).
Magenta Wheel Er	The Cyan Color Wheel is not located in the default position after the reset. This message will appear after the reset of the fixture reset if the magnetic-indexing circuit malfunctions (sensor failed or magnet is missing) or there is a stepper motor failure (defective motor or defective motor IC drive on main PCB).
Yellow Wheel Er	The Yellow Color Wheel is not located in the default position after the reset. This message will appear after the reset of the fixture reset if the magnetic-indexing circuit malfunctions (sensor failed or magnet is missing) or there is a stepper motor failure (defective motor or defective motor IC drive on main PCB).
Color Wheel Er	The Color Wheel is not located in the default position after the reset. This message will appear after the reset of the fixture reset if the magnetic-indexing circuit malfunctions (sensor failed or magnet is missing) or there is a stepper motor failure (defective motor or defective motor IC drive on main PCB).
CTO Wheel Er	The CTO Color Wheel movement is not located in the default position after the reset. This message will appear after a fixture reset if the gobo wheel's magnetic-indexing circuit malfunctions (sensor failed or magnet is missing) or there is a stepper motor failure (defective motor or defective motor IC drive on main PCB).
Rotating Gobo Wheel Er	The Rotating Gobo Wheel movement is not located in the default position after the reset. This message will appear after a fixture reset if the gobo wheel's magnetic-indexing circuit malfunctions (sensor failed or magnet is missing) or there is a stepper motor failure (defective motor or defective motor IC drive on main PCB).

ERROR CODES

Error Codes are subject to change without any prior written notice.	
ERROR CODES	DESCRIPTION
Rotating Gobo Rotation Er	The Rotating Gobo rotation movement is not located in the default position after the reset. This message will appear after a fixture reset if the gobo wheel's magnetic-indexing circuit malfunctions (sensor failed or magnet is missing) or there is a stepper motor failure (defective motor or defective motor IC drive on main PCB).
Fixed Gobo Wheel Er	The Fixed Gobo Wheel movement is not located in the default position after the reset. This message will appear after a fixture reset if the gobo wheel's magnetic-indexing circuit malfunctions (sensor failed or magnet is missing) or there is a stepper motor failure (defective motor or defective motor IC drive on main PCB).
Prism Wheel 1 Er	The Prism Wheel 1 movement is not located in the default position after the reset. This message will appear after a fixture reset if the gobo wheel's magnetic-indexing circuit malfunctions (sensor failed or magnet is missing) or there is a stepper motor failure (defective motor or defective motor IC drive on main PCB).
Prism Rotation Wheel 1 Er	The Prism Wheel 1 rotation movement is not located in the default position after the reset. This message will appear after a fixture reset if the gobo wheel's magnetic-indexing circuit malfunctions (sensor failed or magnet is missing) or there is a stepper motor failure (defective motor or defective motor IC drive on main PCB).
Prism Wheel 2 Er	The Prism Wheel 2 movement is not located in the default position after the reset. This message will appear after a fixture reset if the gobo wheel's magnetic-indexing circuit malfunctions (sensor failed or magnet is missing) or there is a stepper motor failure (defective motor or defective motor IC drive on main PCB).
Prism Rotation Wheel 2 Er	The Prism Wheel 2 rotation movement is not located in the default position after the reset. This message will appear after a fixture reset if the gobo wheel's magnetic-indexing circuit malfunctions (sensor failed or magnet is missing) or there is a stepper motor failure (defective motor or defective motor IC drive on main PCB).
Focus Er	The Focus movement is not located in the default position after the reset. This message will appear after the reset of the fixture reset if the magnetic-indexing circuit malfunctions (sensor failed or magnet is missing) or there is a stepper motor failure (defective motor or defective motor IC drive on main PCB).
Zoom Er	The Zoom movement is not located in the default position after the reset. This message will appear after a fixture reset if the gobo wheel's magnetic-indexing circuit malfunctions (sensor failed or magnet is missing) or there is a stepper motor failure (defective motor or defective motor IC drive on main PCB).

ERROR CODES

Error Codes are subject to change without any prior written notice.	
ERROR CODES	DESCRIPTION
Animation Wheel Er	The Animation Wheel movement is not located in the default position after the reset. This message will appear after a fixture reset if the magnetic-indexing circuit malfunctions (sensor failed or magnet is missing) or there is a motor failure (defective motor or a defective motor IC drive on the main PCB). This error may also be displayed if the head/yoke was blocked during a reset function.
Dimmer Er	The Dimmer movement is not located in the default position after the reset. This message will appear after a fixture reset if the magnetic-indexing circuit malfunctions (sensor failed or magnet is missing) or there is a motor failure (defective motor or defective motor IC drive on main PCB). This error may also be displayed if the head was blocked during a reset function.
Frost Wheel Er	The Frost Wheel is not located in the default position after the reset. This message will appear after the reset of the fixture reset if the magnetic-indexing circuit malfunctions (sensor failed or magnet is missing) or there is a stepper motor failure (defective motor or defective motor IC drive on main PCB).
Fan Moving Wheel Er	The Fan Moving Wheel is not located in the default position after the reset. This message will appear after the reset of the fixture reset if the magnetic-indexing circuit malfunctions (sensor failed or magnet is missing) or there is a stepper motor failure (defective motor or defective motor IC drive on main PCB).
Array Lens Wheel Er	The Array Lens Wheel is not located in the default position after the reset. This message will appear after the reset of the fixture reset if the magnetic-indexing circuit malfunctions (sensor failed or magnet is missing) or there is a stepper motor failure (defective motor or defective motor IC drive on main PCB).
1U_FanJB1Fault	Error information from JB1 port on 1U01 PCB.
1U_FanJB2Fault	Error information from JB2 port on 1U01 PCB.
3U_FanJB1Fault	Error information from JB1 port on 3U PCB.
3U_FanJB2Fault	Error information from JB2 port on 3U PCB.
4U_FanJB2Fault	Error information from JB2 port on 4U PCB.
5U_FanJB1Fault	Error information from JB1 port on 5U PCB.
6U_FanJB1Fault	Error information from JB1 port on 6U PCB.
7U_FanJB1Fault	Error information from JB1 port on 7U PCB.
7U_FanJB2Fault	Error information from JB2 port on 7U PCB.

ERROR CODES

Error Codes are subject to change without any prior written notice.	
ERROR CODES	DESCRIPTION
Accelerometer Err	Accelerometer calibration failure.
Accelerometer ID Error	Accelerometer fail to read ID information.
Ballast Fault_1	Lamp over voltage. (See BALLAST ERROR NOTE page 36)
Ballast Fault_2	Input voltage too high. (See BALLAST ERROR NOTE page 36)
Ballast Fault_3	Temperature too high. (See BALLAST ERROR NOTE page 36)
Ballast Fault_4	Asymmetry detected. (See BALLAST ERROR NOTE page 36)
Ballast Fault_5	Lamp under voltage. (See BALLAST ERROR NOTE page 36)
Ballast Fault_6	Input voltage too low. (See BALLAST ERROR NOTE page 36)
Ballast Fault_8	NTC defective. (See BALLAST ERROR NOTE page 36)
Ballast Fault_Other	These fault modes are related to driver internal software and hardware malfunction.
BallastWasOver Hot	Record and feedback that fixture once appeared lamp off issue because of ballast temp too high.
Ballast_Uart_Fail	
ShiftFanFault	
Pan Reset Fail	
Tilt Reset Fail	
REPLACE THE LAMP	
Excess Humidity	Humidity >85%
Humidity Warning	Humidity=70%
2U01 Com Fail	IC Chip failure.
3U01 Com Fail	IC Chip failure.
4U01 Com Fail	IC Chip failure.
5U01 Com Fail	IC Chip failure.
6U01 Com Fail	IC Chip failure.
7U01 Com Fail	IC Chip failure.
8U01 Com Fail	IC Chip failure.
9U01 Com Fail	IC Chip failure.

MAINTENANCE



DISCONNECT POWER BEFORE PERFORMING ANY MAINTENANCE!

CLEANING

Frequent cleaning is recommended to insure proper function, optimized light output, and an extended life. The frequency of cleaning depends on the environment in which the fixture operates: damp, smoky or particularly dirty environments can cause greater accumulation of dirt on the fixture's optics. Clean the external lens surface at least every 20 days with a soft cloth to avoid dirt/debris accumulation.

NEVER use alcohol, solvents, or ammonia-based cleaners.

MAINTENANCE

Regular inspections are recommended to insure proper function and extended life.

There are no user serviceable parts inside this fixture, please refer all other service issues to an authorized Elation service technician. Should you need any spare parts, please order genuine parts from your local Elation dealer.

Please refer to the following points during routine inspections:

A detailed electric check by an approved electrical engineer every three months, to make sure the circuit contacts are in good condition and prevent overheating.

Be sure all screws and fasteners are always tightened. Loose screws may fall out during normal operation resulting in damage or injury as larger parts could fall.

Check for any deformations on the housing, color lenses, rigging hardware and rigging points (ceiling, suspension, trussing). Deformations in the housing could allow for dust to enter the fixture. Damaged rigging points or unsecured rigging could cause the fixture to fall and seriously injure a person(s).

Electric power supply cables must not show any damage, material fatigue or sediments. **NEVER** remove the ground prong from the power cable.

FIXTURE DISASSEMBLY

The following points should be observed after performing any maintenance procedure that requires disassembly of the unit:

- After the unit has been reassembled, open the valve, and allow the light to run for approximately 2 hours to dry out any moisture that has been trapped inside the fixture. The process should continue until indicated humidity drops below 15% for the head and 30% for the base.
- Once this has been achieved, the light can be switched off, but the unit should remain connected to power so that the cooling fan can cool down the unit. Please note that allowing cool down time should **ALWAYS** be done after lamp operation.
- Some units may require partial disassembly to gain access to the valve. Please contact Elation service for information regarding the location and access procedure for the valve on your specific unit model.

SPECIFICATIONS

SOURCE

Philips MSD 21R 470W 8,000K Lamp
1,000 Hour Average LAMP Life*

*LAMP Life may vary depending on several factors including but not limited to: Environmental Conditions, Power/Voltage, Usage Patterns (On-Off Cycling), Control, and Dimming.

PHOTOMETRIC DATA

CRI 80 | >14,000 Lumens
13,375 LUX 1,243 FC @49.2' (15m) (3.0° Spot)
233,000 LUX 21,646 FC @49.2' (15m) (2.0° Beam)
11,500 LUX 1,068 FC @16.4' (15m) (4.0° Wash)
Zoom Range
Beam 2.1° - 21.5°
Spot: 2.8° - 28.6°
Wash: 4° - 31.2°

EFFECTS

Full 360° Bi-Directional Animation Wheel
Rotating Prisms and Prism Macros
Frost Filter Hybrid Wash Effect
Motorized Focus and Auto-Focus
High Speed Mechanical Shutter and Strobe
Pan Angle: 540°/630°
Tilt Angle: 265°

COLOR

14 Dichroic Colors Including CTB, CTO, and UV
Full CMY Color Mixing and Linear CTO Color Correction

GOBOS

8 Interchangeable Rotating / Indexing Glass Gobos
14 Static-Stamped Metal Gobos

CONTROL / CONNECTIONS

(3) DMX Channel Modes (24 / 26 / 37)
6 Button Touch Control Panel
Full Color 180° Reversible LCD Menu Display
8 / 16 Bit Resolution Adjustable Movement
DMX, RDM, Art-NET, and sACN Protocol Support
Elation's E-FLY™ Internal Wireless DMX Transceiver
IP65 5pin DMX In/Out
IP65 RJ45 ethernet In/Out
IP65 Locking Power Cable In
With Wired Digital Communication Network

SIZE / WEIGHT

Length: 18.45" (465mm)
Width: 22.5" (571mm)
Vertical Height: 37.1" (805mm)
Center-to-Center Spacing: 26.4" (671mm)
Weight: 84.0 lbs. (38 kg)

ELECTRICAL / THERMAL

AC 100-240V - 50/60Hz
700W Max Power Consumption
14°F to 113°F (-10°C to 45°C)

APPROVALS / RATINGS

CE | cETLus | IP65



Specifications and documentation subject to change without notice.

COLORS AND GOBOS

COLOR FLAGS



CYAN MAGENTA YELLOW CTO

COLOR WHEEL

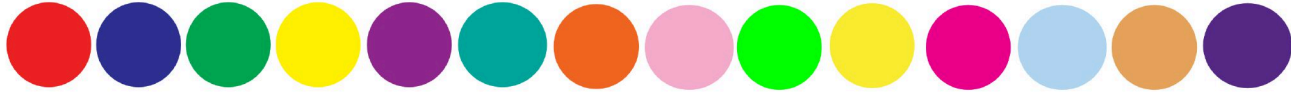

RED 1 BLUE 2 GREEN 3 YELLOW 4 PURPLE 5 AGUA 6 ORANGE 7 LT PINK 8 LIME 9 LT YELLOW 10 MAGENTA 11 CTO 12 CTB 13 UV 14

INTERCHANGEABLE-ROTATING GOBO WHEEL 1



1 2 3 4 5 6 7 8

STATIC-FIXED GOBO WHEEL 2

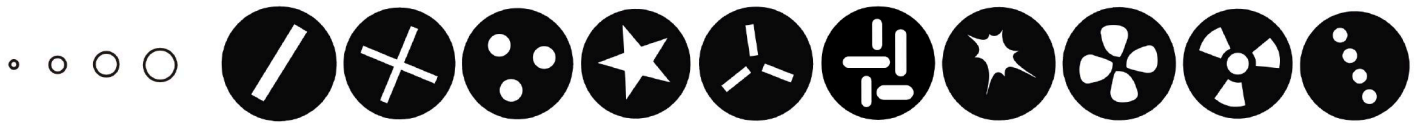

1 2 3 4 5 6 7 8 9 10 11 12 13 14

ANIMATION WHEEL

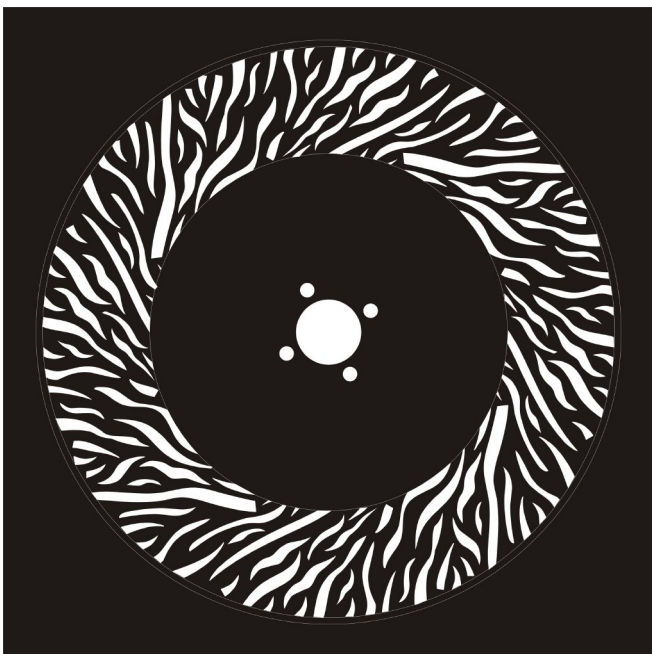

DIMENSIONAL DRAWINGS

Drawing not to scale

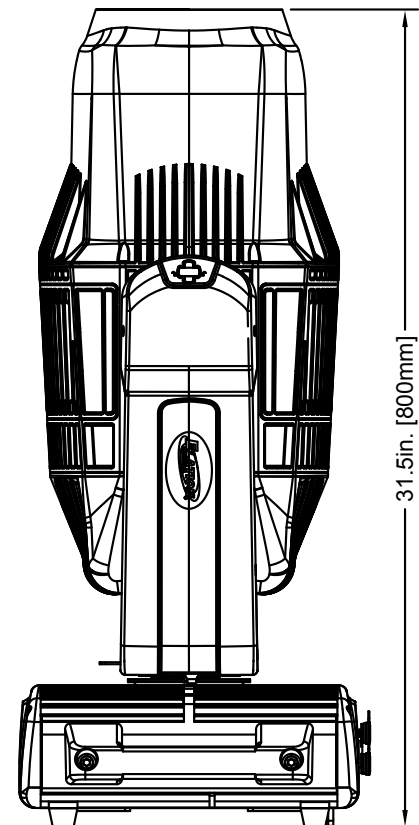
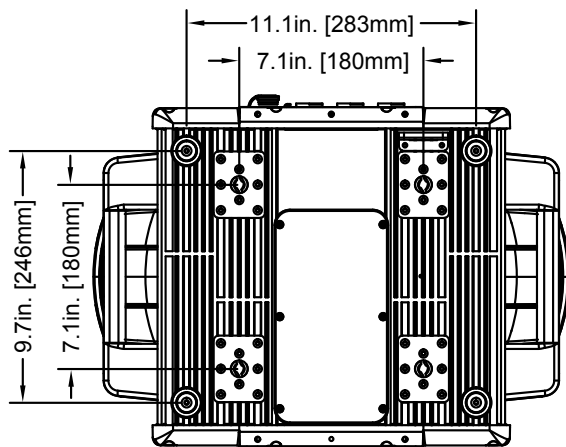
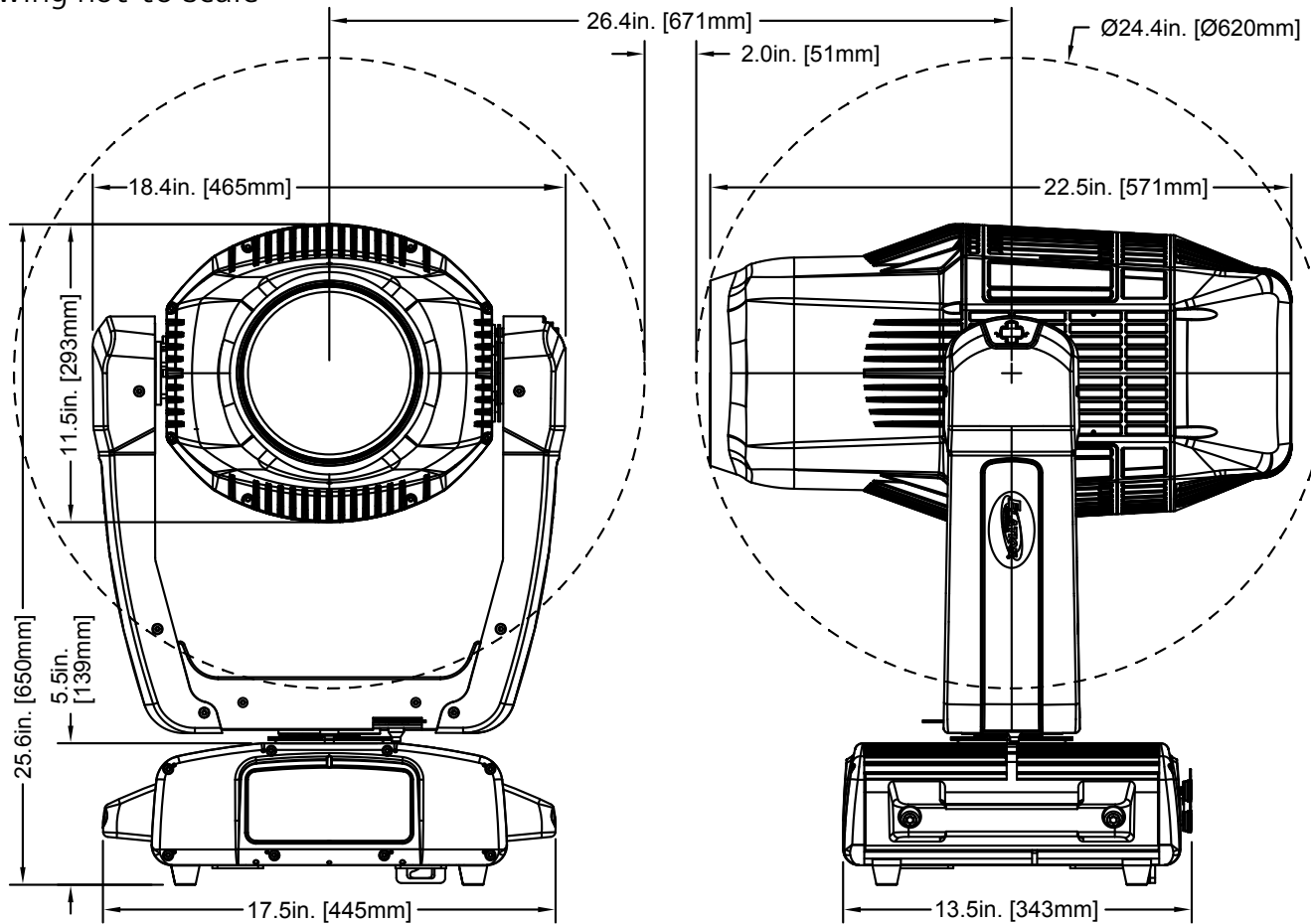

OPTIONAL ACCESSORIES

ORDER CODE	ITEM
TRIGGER CLAMP	Heavy Duty Wrap Around Hook Style Clamp
ELF001	E-FLY™ Wireless DMX Transceiver
DRCPROHYBRID1	Single Road Case for PROTEUS HYBRID
DRCPROHYBX2W	Dual Road Case for PROTEUS HYBRID
IP TESTER	IP Fixture Vacuum and Pressure Leak Tester

FCC STATEMENT

This device complies with Part 15 of the FCC Rules. Operation is subject to the following two conditions: (1) this device may not cause harmful interference, and (2) this device must accept any interference received, including interference that may cause undesired operation.

FCC RADIO FREQUENCY INTERFERENCE WARNINGS & INSTRUCTIONS

This product has been tested and found to comply with the limits as per Part 15 of the FCC Rules. These limits are designed to provide reasonable protection against harmful interference in a residential installation. This device uses and can radiate radio frequency energy and, if not installed and used in accordance with the included instructions, may cause harmful interference to radio communications. However, there is no guarantee that interference will not occur in a particular installation. If this device does cause harmful interference to radio or television reception, which can be determined by turning the device off and on, the user is encouraged to try to correct the interference by one or more of the following methods:

- Reorient or relocate the device.
- Increase the separation between the device and the receiver.
- Connect the device to an electrical outlet on a circuit different from which the radio receiver is connected.
- Consult the dealer or an experienced radio/TV technician for help.

Europe Energy Saving Notice

Energy Saving Matters (EuP 2009/125/EC)

Saving electric energy is a key to help protecting the environment. Please turn off all electrical products when they are not in use. To avoid power consumption in idle mode, disconnect all electrical equipment from power when not in use. Thank you



