

Matrix Switcher Accessories

FPC 6000

Front Panel Controller

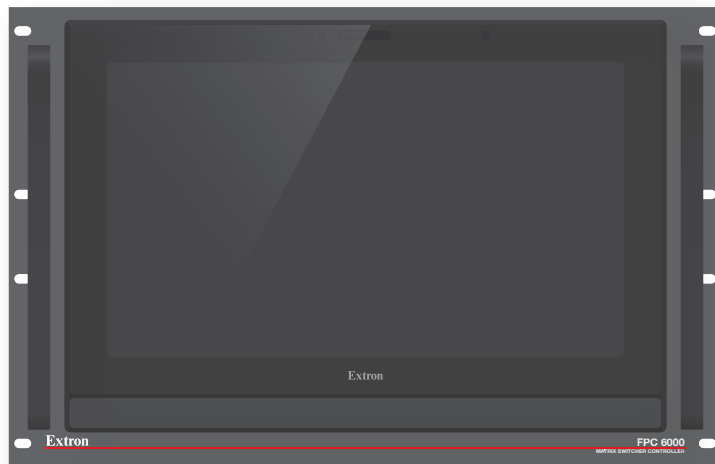

Safety Instructions

Safety Instructions • English

WARNING: This symbol, , when used on the product, is intended to alert the user of the presence of uninsulated dangerous voltage within the product's enclosure that may present a risk of electric shock.

ATTENTION: This symbol, , when used on the product, is intended to alert the user of important operating and maintenance (servicing) instructions in the literature provided with the equipment.

For information on safety guidelines, regulatory compliances, EMI/EMF compatibility, accessibility, and related topics, see the Extron Safety and Regulatory Compliance Guide, part number 68-290-01, on the Extron website, www.extron.com.

Sicherheitsanweisungen • Deutsch

WARNUNG: Dieses Symbol , auf dem Produkt soll den Benutzer darauf aufmerksam machen, dass im Inneren des Gehäuses dieses Produktes gefährliche Spannungen herrschen, die nicht isoliert sind und die einen elektrischen Schlag verursachen können.

VORSICHT: Dieses Symbol , auf dem Produkt soll dem Benutzer in der im Lieferumfang enthaltenen Dokumentation besonders wichtige Hinweise zur Bedienung und Wartung (Instandhaltung) geben.

Weitere Informationen über die Sicherheitsrichtlinien, Produkthandhabung, EMI/EMF-Kompatibilität, Zugänglichkeit und verwandte Themen finden Sie den Extron-Richtlinien für Sicherheit und Handhabung (Artikelnummer 68-290-01) auf der Extron-Website, www.extron.com.

Instrucciones de seguridad • Español

ADVERTENCIA: Este símbolo, , cuando se utiliza en el producto, avisa al usuario de la presencia de voltaje peligroso sin aislar dentro del producto, lo que puede representar un riesgo de descarga eléctrica.

ATENCIÓN: Este símbolo, , cuando se utiliza en el producto, avisa al usuario de la presencia de importantes instrucciones de uso y mantenimiento recogidas en la documentación proporcionada con el equipo.

Para obtener información sobre directrices de seguridad, cumplimiento de normativas, compatibilidad electromagnética, accesibilidad y temas relacionados, consulte la Guía de cumplimiento de normativas y seguridad de Extron, referencia 68-290-01, en el sitio Web de Extron, www.extron.com.

Instructions de sécurité • Français

AVERTISSEMENT : Ce pictogramme, , lorsqu'il est utilisé sur le produit, signale à l'utilisateur la présence à l'intérieur du boîtier du produit d'une tension électrique dangereuse susceptible de provoquer un choc électrique.

ATTENTION : Ce pictogramme, , lorsqu'il est utilisé sur le produit, signale à l'utilisateur des instructions d'utilisation ou de maintenance importantes qui se trouvent dans la documentation fournie avec le matériel.

Pour en savoir plus sur les règles de sécurité, la conformité à la réglementation, la compatibilité EMI/EMF, l'accessibilité, et autres sujets connexes, lisez les informations de sécurité et de conformité Extron, réf. 68-290-01, sur le site Extron, www.extron.com.

Istruzioni di sicurezza • Italiano

AVVERTENZA: Il simbolo, , se usato sul prodotto, serve ad avvertire l'utente della presenza di tensione non isolata pericolosa all'interno del contenitore del prodotto che può costituire un rischio di scosse elettriche.

ATTENZIONE: Il simbolo, , se usato sul prodotto, serve ad avvertire l'utente della presenza di importanti istruzioni di funzionamento e manutenzione nella documentazione fornita con l'apparecchio.

Per informazioni su parametri di sicurezza, conformità alle normative, compatibilità EMI/EMF, accessibilità e argomenti simili, fare riferimento alla Guida alla conformità normativa e di sicurezza di Extron, cod. articolo 68-290-01, sul sito web di Extron, www.extron.com.

Instrukcja bezpieczeństwa • Polska

OSTRZEŻENIE: Ten symbol, , gdy używany na produkt, ma na celu poinformować użytkownika o obecności izolowanego i niebezpiecznego napięcia wewnątrz obudowy produktu, który może stanowić zagrożenie porażenia prądem elektrycznym.

UWAGI: Ten symbol, , gdy używany na produkt, jest przeznaczony do ostrzegania użytkownika ważne operacyjne oraz instrukcje konserwacji (obsługi) w literaturze, wyposażone w sprzęt.

Informacji na temat wytycznych w sprawie bezpieczeństwa, regulacji wzajemnej zgodności, zgodność EMI/EMF, dostępności i Tematy pokrewne, zobacz Extron bezpieczeństwa i regulacyjnego zgodności przewodnik, część numer 68-290-01, na stronie internetowej Extron, www.extron.com.

Инструкция по технике безопасности • Русский

ПРЕДУПРЕЖДЕНИЕ: Данный символ, , если указан на продукте, предупреждает пользователя о наличии неизолированного опасного напряжения внутри корпуса продукта, которое может привести к поражению электрическим током.

ВНИМАНИЕ: Данный символ, , если указан на продукте, предупреждает пользователя о наличии важных инструкций по эксплуатации и обслуживанию в руководстве, прилагаемом к данному оборудованию.

Для получения информации о правилах техники безопасности, соблюдении нормативных требований, электромагнитной совместимости (ЭМП/ЭДС), возможности доступа и других вопросах см. руководство по безопасности и соблюдению нормативных требований Extron на сайте Extron: www.extron.com, номер по каталогу - 68-290-01.

安全说明 • 简体中文

警告: 产品上的这个标志意在警告用户该产品机壳内有暴露的危险电压, 有触电危险。

注意: 产品上的这个标志意在提示用户设备随附的用户手册中有重要的操作和维护(维修)说明。

关于我们产品的安全指南、遵循的规范、EMI/EMF 的兼容性、无障碍使用的特性等相关内容, 敬请访问 Extron 网站, www.extron.com, 参见 Extron 安全规范指南, 产品编号 68-290-01。

安全記事・繁體中文

警告: ⚠️ 若產品上使用此符號，是為了提醒使用者，產品機殼內存在著可能會導致觸電之風險的未絕緣危險電壓。

注意: ⚠️ 若產品上使用此符號，是為了提醒使用者，設備隨附的用戶手冊中有重要的操作和維護（維修）說明。

有關安全性指導方針、法規遵守、EMI/EMF 相容性、存取範圍和相關主題的詳細資訊，請瀏覽 Extron 網站：www.extron.com，然後參閱《Extron 安全性與法規遵守手冊》，準則編號 68-290-01。

安全上のご注意・日本語

警告: この記号 ⚠️ が製品上に表示されている場合は、筐体内に絶縁されていない高電圧が流れ、感電の危険があることを示しています。

注意: この記号 ⚠️ が製品上に表示されている場合は、本機の取扱説明書に記載されている重要な操作と保守（整備）の指示についてユーザーの注意を喚起するものです。

安全上のご注意、法規遵守、EMI/EMF適合性、その他の関連項目については、エクストロンのウェブサイト www.extron.com より『Extron Safety and Regulatory Compliance Guide』（P/N 68-290-01）をご覧ください。

안전 지침 · 한국어

경고: 이 기호 ⚠️ 가 제품에 사용될 경우, 제품의 인클로저 내에 있는 접지되지 않은 위험한 전류로 인해 사용자가 감전될 위험이 있음을 경고합니다.

주의: 이 기호 ⚠️ 가 제품에 사용될 경우, 장비와 함께 제공된 책자에 나와 있는 주요 운영 및 유지보수(정비) 지침을 경고합니다.

안전 가이드라인, 규제 준수, EMI/EMF 호환성, 접근성, 그리고 관련 항목에 대한 자세한 내용은 Extron 웹 사이트(www.extron.com)의 Extron 안전 및 규제 준수 안내서, 68-290-01 조항을 참조하십시오.

Copyright

© 2017-2020 Extron Electronics. All rights reserved. www.extron.com

Trademarks

All trademarks mentioned in this guide are the properties of their respective owners.

The following registered trademarks (®), registered service marks (SM), and trademarks (TM) are the property of RGB Systems, Inc. or Extron Electronics (see the current list of trademarks on the [Terms of Use](#) page at www.extron.com):

Registered Trademarks (®)

Cable Cubby, ControlScript, CrossPoint, DTP, eBUS, EDID Manager, EDID Minder, Extron, Flat Field, FlexOS, Glitch Free, Global Configurator, Global Scriptor, GlobalViewer, Hideaway, HyperLane, IP Intercom, IP Link, Key Minder, LinkLicense, LockIt, MediaLink, MediaPort, NetPA, PlenumVault, PoleVault, PowerCage, PURE3, Quantum, ShareLink, Show Me, SoundField, SpeedMount, SpeedSwitch, StudioStation, System *INTEGRATOR*, TeamWork, TouchLink, V-Lock, VideoLounge, VN-Matrix, VoiceLift, WallVault, WindoWall, XPA, XTP, XTP Systems, and ZipClip

Registered Service Mark (SM): S3 Service Support Solutions

Trademarks (TM)

AAP, AFL (Accu-Rate Frame Lock), ADSP (Advanced Digital Sync Processing), Auto-Image, AVEdge, CableCover, CDRS (Class D Ripple Suppression), Codec Connect, DDSP (Digital Display Sync Processing), DMI (Dynamic Motion Interpolation), Driver Configurator, DSP Configurator, DSVP (Digital Sync Validation Processing), eLink, EQIP, Everlast, FastBite, Flex55, FOX, FOXBOX, IP Intercom HelpDesk, MAAP, MicroDigital, Opti-Torque, PendantConnect, ProDSP, QS-FPC (QuickSwitch Front Panel Controller), Room Agent, Scope-Trigger, SIS, Simple Instruction Set, Skew-Free, SpeedNav, Triple-Action Switching, True4K, True8K, Vector™ 4K, WebShare, XTRA, and ZipCaddy

FCC Class A Notice

This equipment has been tested and found to comply with the limits for a Class A digital device, pursuant to part 15 of the FCC rules. The Class A limits provide reasonable protection against harmful interference when the equipment is operated in a commercial environment. This equipment generates, uses, and can radiate radio frequency energy and, if not installed and used in accordance with the instruction manual, may cause harmful interference to radio communications. Operation of this equipment in a residential area is likely to cause interference. This interference must be corrected at the expense of the user.

NOTE: For more information on safety guidelines, regulatory compliances, EMI/EMF compatibility, accessibility, and related topics, see the [Extron Safety and Regulatory Compliance Guide](#) on the Extron website.

Battery Notice

This product contains a battery. **Do not open the unit to replace the battery.** If the battery needs replacing, return the entire unit to Extron (for the correct address, see the [Extron Warranty](#) section on the last page of this guide).

CAUTION: Risk of explosion if battery is replaced by an incorrect type. Dispose of used batteries according to the instructions.

ATTENTION : Risque d'explosion. Ne pas remplacer la pile par le mauvais type de pile. Débarrassez-vous des piles utilisées selon le mode d'emploi.

Conventions Used in this Guide

Notifications

In this user guide, the following are used:

⚠ WARNING: Potential risk of severe injury or death.
AVERTISSEMENT : Risque potentiel de blessure grave ou de mort.

CAUTION: Risk of minor personal injury.
ATTENTION : Risque de blessure mineure.

ATTENTION:

- Risk of property damage.
- Risque de dommages matériels.

NOTE: A note draws attention to important information.

Software Commands

Commands are written in the fonts shown here:

```
^ARMerge Scene , ,Op1 scene 1,1 ^B51 ^W^C  
[Ø1] RØØØ4 ØØ3ØØ ØØ4ØØ ØØ8ØØ ØØ6ØØ [Ø2] 35 [17] [Ø3]  
[Esc][X1]*[X17]*[X20]*[X23]*[X21]CE←
```

NOTE: For commands and examples of computer or device responses mentioned in this guide, the character “Ø” is used for the number zero and “O” represents the capital letter “o”.

Computer responses and directory paths that do not have variables are written in the font shown here:

```
Reply from 2Ø8.132.18Ø.48: bytes=32 times=2ms TTL=32  
C:\Program Files\Extron
```

Variables are written in slanted form as shown here:

```
ping xxx.xxx.xxx.xxx -t  
SOH R Data STX Command ETB ETX
```

Selectable items, such as menu names, menu options, buttons, tabs, and field names are written in the font shown here:

```
From the File menu, select New.  
Click the OK button.
```

Specifications Availability

Product specifications are available on the Extron website, www.extron.com.

Extron Glossary of Terms

A glossary of terms is available at www.extron.com/technology/glossary.aspx.



Contents

Introduction.....	1
About This Guide	1
About the FPC 6000	1
Features.....	1
Application Diagram	2
Matrix Switcher Terms.....	3

Installation Overview 4

Mounting.....	6
Installing the FPC 6000 in a Rack or Control Console.....	6
Underwriters Laboratories Guidelines for Rack Mounting.....	7
Wall Mounting the FPC 6000.....	7

Panel Features	9
Front Panel Features	9
Rear Panel Features.....	10

Setup Menu.....	13
Setup Menu	13
Status	13
Network.....	14
Display.....	16
Audio.....	17
Advanced	18

FPC 6000 Web Page.....	19
FPC 6000 Web Page	19
Updating the Firmware.....	20
Downloading Firmware.....	20
Updating Firmware Using the Touchpanel Web Page.....	21

Operation.....	22
Login Screen.....	22
Ties Screen.....	24
Menu Buttons	25
Input Buttons	25
Output Buttons	25
Mute Selection Buttons.....	26
Mute Control Button	26
Select All.....	26
Take.....	26
Break.....	26
Clear Selection.....	26
Create a Tie	27
Break A Tie	28
Change View.....	30
Presets	32
Status Screen	37
I/O Info Screen.....	37
Customize Screen.....	39

Reset Modes.....	40
Use Factory Firmware	40
Activation	40
Result	40
Reset All IP Settings.....	41
Activation	41
Result	41
Reset to Factory Defaults	41
Activation.....	41
Result	42

Introduction

- [About This Guide](#)
- [About the FPC 6000](#)
- [Features](#)
- [Application Diagram](#)
- [Matrix Switcher Terms](#)

About This Guide

This guide describes how to install, configure, and operate the Extron FPC 6000 Front Panel Controller. Unless otherwise stated, the terms “Front Panel Controller,” “touchpanel,” and “FPC” refer to the Extron FPC 6000.

About the FPC 6000

The FPC 6000 uses an Extron TLP Pro 1520M TouchLink touchscreen to provide an intuitive, 15-inch control interface with straightforward menus for quick and easy system configuration.

The FPC 6000 is a stand-alone device that does not require an additional external controller or configuration with Global Configurator Plus and Professional or GUI Designer software.

The FPC 6000 supports the following Extron matrix switchers:

- FOX 3200 Matrix
- FOX 7200 Matrix
- FOX 14400 Matrix
- FOX 320x Matrix

NOTE: Additional matrix switchers will be added in the future. See www.extron.com for the most recent information about compatible matrix switchers.

Features

- **Compatible with the Extron FOX 3200 Matrix, FOX 7200 Matrix, FOX 14400 Matrix, and FOX 320x Matrix**
- **Intuitive, menu-driven 15" color touchscreen control interface**
- **Global presets** — FOX 3200 models support up to 32 global presets. Other models support up to 64 global presets. This time-saving feature allows frequently used I/O configurations to be saved, stored in memory, and recalled using the FPC 6000.
- **Rooming** — Provides up to 10 presets for each of 10 virtual rooms for a total of up to 100 rooming presets for added flexibility and control in routing signals.
- **Remote monitoring, access, and management of all set-up and control functions**
- **Ethernet capabilities** — For matrix control from one or more locations over a local area network
- **Multiple matrix control** — The controller is capable of storing up to ten IP addresses.
- **7U, rack-mountable panel** — Can also be installed in a control console.
- **Includes a PI 140 Power Injector** — The FPC 6000 receives power and communication over a single Ethernet cable, eliminating the need for a local power supply.

Application Diagram

FOX AV Transmitter Multimode

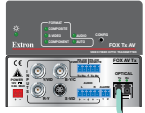

FOXBOX Tx HDMI Transmitter Multimode



FOX T USW 103 Transmitter Multimode



FOXBOX Tx VGA/YUV Transmitter Singlemode



FOX 3G HD-SDI Transceiver Multimode



FOX AV Receiver Multimode



FOXBOX SR HDMI Receiver Multimode



FOXBOX Rx VGA Receiver Singlemode



FOXBOX DVI Plus Receiver Singlemode



FOX 3G HD-SDI Transceiver Singlemode



Legend

Singlemode

Multimode

Ethernet

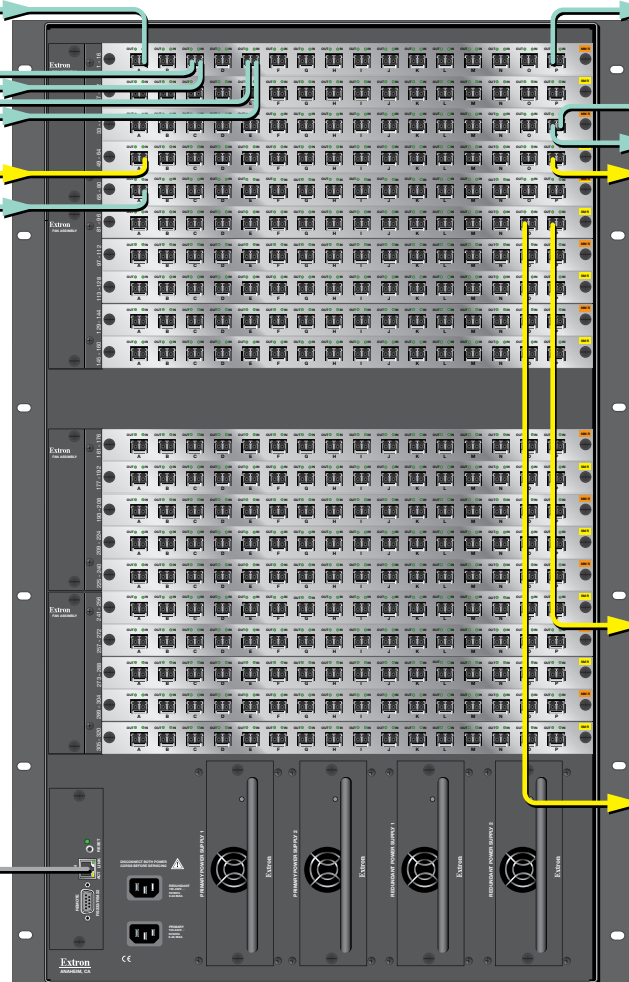

Extron FOX Matrix 320x
Modular Fiber Optic Matrix Switch



Extron PI 140 High Power Injector

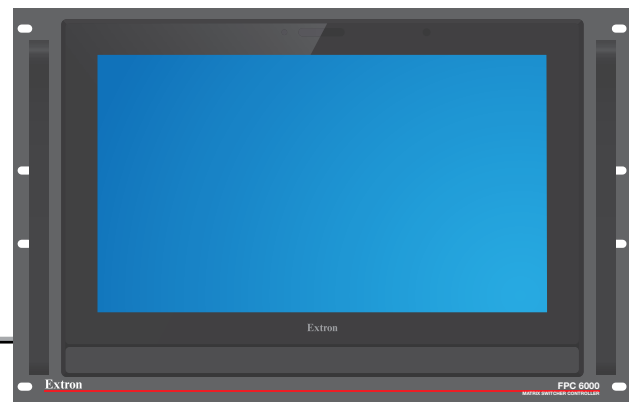

Extron FPC 6000

Figure 1. FPC 6000 Application Diagram

Matrix Switcher Terms

The following terms, which are used throughout this guide, apply to Extron matrix switchers:

- **Tie** — An input-to-output connection.
- **Set of ties** — An input tied to two or more outputs. (An output can never be tied to more than one input).
- **Configuration** — One tie or one or more sets of ties.
- **Current configuration** — The configuration that is currently being used (also called Configuration 0).
- **Global memory preset** — A configuration that has been stored. FOX 3200 models support up to 32 global presets. Other models support up to 64 global presets. When a global preset is retrieved from memory, it becomes the current configuration.
- **Room** — A room consists of a smaller subset of virtual outputs that are logically related to each other, as determined by the operator. All FOX matrix switchers support up to 10 rooms, each of which consists of from 1 to 16 virtual outputs. Each room can have up to 10 presets.
- **Room memory preset** — A configuration consisting of virtual outputs in a single room that has been stored. When a room preset is retrieved from memory, it becomes the current configuration.
- **SFP** — Small form-factor pluggable. The SFP is an interface used in fiber optic connections for direct signal connections or packet switched networks.

NOTE: The number of rooms and presets that are available depends on the matrix switcher that is connected to the FPC 6000. See the user guide for the matrix switcher at www.extron.com for further information.

Installation Overview

This section provides an overview of the installation process. Follow the links for a more detailed explanation of each step.

The FPC 6000 consists of:

- (1) 15" touchpanel
 - (1) PoE power injector
 - (1) 7U high, 19 inch wide, rack-mountable metal panel
1. Obtain the following network information from your network administrator:
 - Dynamic Host Configuration Protocol (DHCP) status** (on or off). If DHCP is off, you also require:
 - IP address for the FPC 6000**
 - Subnet mask for the FPC 6000**
 - Gateway for the FPC 6000**
 - User name for the FPC 6000** — By default, this is `admin`
 - Password for the FPC 6000**

NOTES:

- The factory configured passwords for all accounts on this device have been set to the device serial number. Passwords are case sensitive.
- If the device is reset to default settings, the password will be the default password configuration. The default password is `extron`.
- To change the password, you must use the Extron Toolbelt utility (see the *Toolbelt Help File*). Talk to your Extron rep about obtaining a license for Toolbelt.

- IP address for the matrix switcher**
 - Password for the matrix switcher** — See the user guide for your matrix switcher for information about the password.
2. Decide where the FPC 6000 will be mounted (see [Mounting](#) on page 6).
 3. Cable the unit:
 - If you are using the provided PoE power injector, connect the FPC 6000 to the power injector and connect the power injector to the Ethernet LAN (see [figure 6](#) on page 11).
 - If you are using a 12 VDC power supply (not provided), connect the FPC 6000 directly to the LAN (see [XTP/LAN/PoE input](#) on page 11) and connect the power supply to FPC 6000.

ATTENTION:

- Do not power on the FPC 6000 until you have read the [Attention notifications](#) about power supplies (see page 11).
- Ne branchez pas le FPC 6000 avant d'avoir lu les [mises en garde](#) sur les sources d'alimentation (voir page 11).

-
4. Set up the FPC 6000 for Network Communication:
 - Use the **Setup Menu** (see page 13) to set the DHCP status and, if required, the IP address, subnet mask, gateway, and related settings for the FPC 6000.
 - Test the connection to the switcher.

Mounting

When the FPC 6000 ships, it is housed in a 7U high, 19 inch wide, rack-mountable panel that can be installed in any standard equipment rack or control console. Follow the instructions below and read the [Underwriters Laboratories Guidelines for Rack Mounting](#) on the next page.

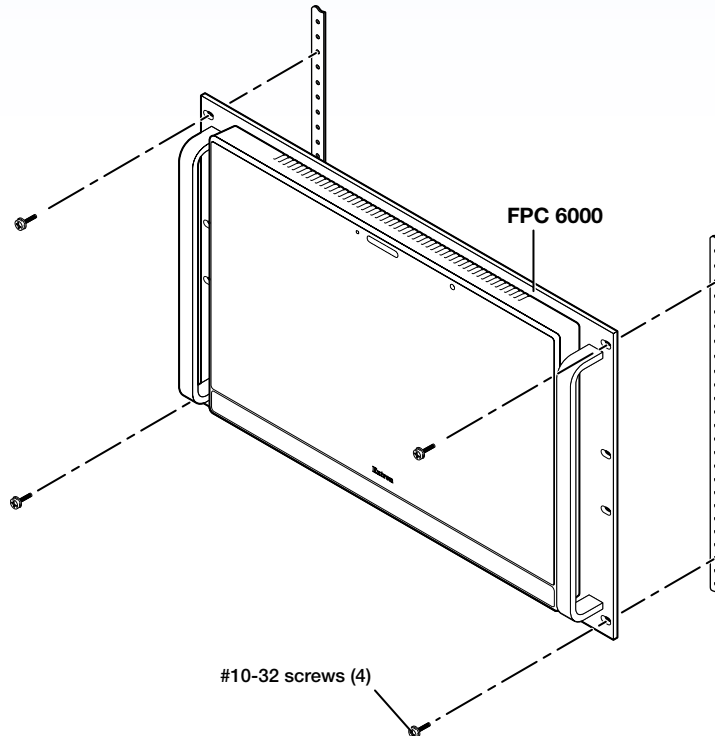

Figure 2. Rack Mounting the FPC 6000

Installing the FPC 6000 in a Rack or Control Console

The FPC 6000 is housed in a rack-mountable panel when it ships.

ATTENTION:

- All structural steps and electrical installation must be performed by qualified personnel in accordance with local and national building codes and electrical codes.
- Toute étape structurelle et installation électrique, doit être effectuée par un personnel qualifié, conformément aux codes du bâtiment, aux codes incendie et sécurité, et aux codes électriques, locaux et nationaux.
- Do not install the FPC 6000 in a fire resistant rated wall or partition assembly.
- Ne pas installer le FPC 6000 dans un mur résistant au feu ou une cloison.

1. Decide where the FPC 6000 will be mounted.
2. Use the four provided rack-mounting screws to secure the FPC 6000 to any standard equipment rack or control console. Follow the instructions in the [Underwriters Laboratories Guidelines for Rack Mounting](#) (see the next page) to ensure the rack is mounted safely.

Underwriters Laboratories Guidelines for Rack Mounting

The following Underwriters Laboratories (UL) guidelines are relevant to the safe installation of the FPC 6000 in a rack:

- **Elevated operating ambient temperature** — If the unit is installed in a closed or multi-unit rack assembly, the operating ambient temperature of the rack environment may be greater than room ambient temperature. Therefore, install the equipment in an environment compatible with the maximum ambient temperature (T_{ma}: +104 °F, +40 °C) specified by Extron.
- **Reduced air flow** — Install the equipment in the rack so that the equipment gets adequate air flow for safe operation.
- **Mechanical loading** — Mount the equipment in the rack so that uneven mechanical loading does not create a hazardous condition.
- **Circuit overloading** — Connect the equipment to the supply circuit and consider the effect that circuit overloading might have on overcurrent protection and supply wiring. Give appropriate consideration to the equipment nameplate ratings when addressing this concern.
- **Reliable earthing (grounding)** — Maintain reliable grounding of rack-mounted equipment. Pay particular attention to supply connections other than direct connections to the branch circuit (such as the use of power strips).

Wall Mounting the FPC 6000

The FPC 6000 can also be wall-mounted, either using the Extron BB 700M wall box or directly into drywall. Some local building codes require the touchpanel to be mounted in a wall box. To use the BB 700M, see the *TLP Pro 1220MG*, *TLP Pro 1520MG*, and *TLP Pro 1720MG Setup Guide*, at www.extron.com. If the wall box is not required by local building codes, you can mount the touchpanel directly into drywall.

ATTENTION:

- Do not install the FPC 6000 in a fire resistant rated wall or partition assembly.
- Ne pas installer le FPC 6000 dans un mur résistant au feu ou une cloison.
- All structural steps and electrical installation must be performed by qualified personnel in accordance with local and national building codes and electrical codes.
- Toute étape structurelle et installation électrique, doit être effectuée par un personnel qualifié, conformément aux codes du bâtiment, aux codes incendie et sécurité, et aux codes électriques, locaux et nationaux.

1. Download the cut-out template for the TLP Pro 1520MG from www.extron.com. Print it at 100% (no scaling).
2. Use the template to mark the wall, cut the hole, and drill the four pilot holes (see figure 3, ❶).
The size of the cut-out hole is 8.90 inches (22.61 cm) wide x 5.70 inches (14.48 cm) high.
3. The FPC 6000 ships, already mounted, in a rack-mountable metal panel. Remove the FPC 6000 from the panel and, remove the mounting plate that is attached to the panel by screws.
4. Secure the mounting plate to the mounting surface with four #10 screws (❷). The installer must use screws and fasteners that are appropriate for the mounting surface.
5. Run and connect cables to the back of the touchpanel (❸, see [Rear Panel Features](#) on page 10).
6. Insert the two provided Phillips pan head #6-32 x 3/4-inch length screws with washers in the mounting screw slot (❹). Leave a gap for the flange at the bottom of the mounting plate to fit into.
7. Hold the touchpanel at a slight angle and lower the notches at the top of the back panel over the hooks of the mounting plate (❺).
8. Swing the bottom of the touchpanel inwards so that it lies flat against the mounting plate with the flange at the bottom of the mounting plate sitting in a groove in the bottom of the touchpanel.
9. Secure the touchpanel to the mounting plate with the mounting screws (❻).

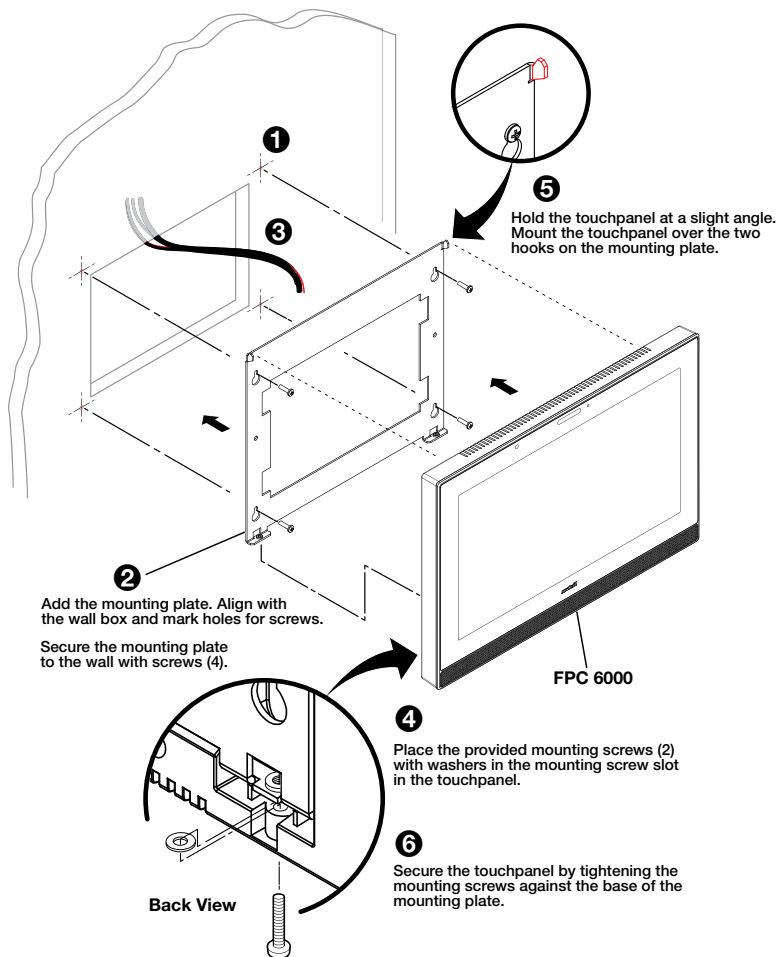

Figure 3. Wall Mounting the FPC 6000

Panel Features

This section describes:

- [Front Panel Features](#)
- [Rear Panel Features](#)

Front Panel Features

Figure 4 shows the front panel of the FPC 6000, removed from the mounting frame.

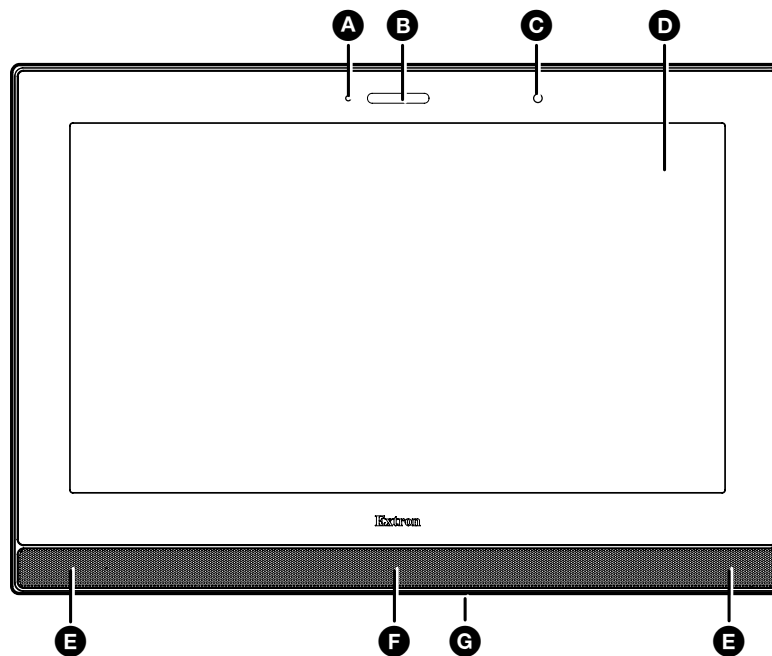

Figure 4. FPC 6000 Front Panel

- A Communication LED** — Lights briefly when the unit boots up. Otherwise, this LED has no function on the FPC 6000.
- B Status light** — Lights briefly when the unit boots up. Otherwise, this light has no function on the FPC 6000.
- C Ambient light sensor** — Monitors ambient light level and adjusts screen brightness.
- D Capacitive touch screen** — The FPC 6000 has a 15.6 inch screen with 1366x768 resolution.
- E Speakers** — Provide audible feedback from button presses.
- F Motion sensor** — Detects motion in front of the touchpanel.
- G Menu button** — Activates the setup menu and calibration screen (see [Setup Menu](#) on page 13). It is accessed from under the touchpanel. It performs the same function as the rear panel Menu button but is easier to reach when the touchpanel is installed.

NOTE: Extron recommends using the **FPC Settings** link on the Login screen (see [figure 20](#) on page 22) to open the setup menu.

Rear Panel Features

Figure 5 shows the rear panel of the FPC 6000, removed from the mounting frame.

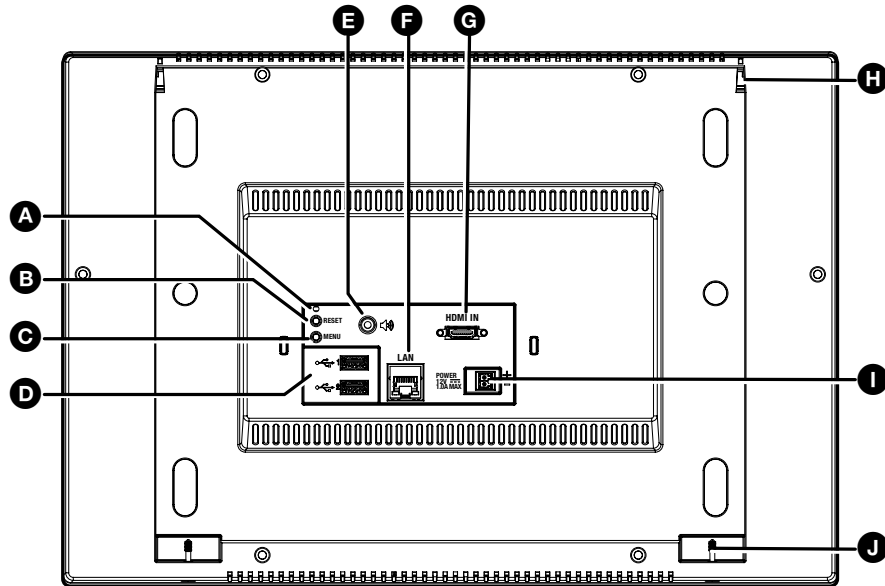

Figure 5. FPC 6000 Rear Panel

- | | |
|-------------------------|---|
| A Reset LED | F XTP/LAN/PoE input (see next page) |
| B Reset button | G HDMI input (see page 12) |
| C Menu button | H Mounting notches (see page 12) |
| D USB connectors | I 12 VDC power supply input (see page 12) |
| E Audio output | J Mounting screws (see page 12) |

- A Reset LED** — Provides feedback about the reset status when the user presses the reset button (see **Reset Modes** on page 40)
- B Reset button** — Pressing the Reset button allows the unit to be reset in any of three different modes (see **Reset Modes**).
- C Menu button** — Activates the setup menu and calibration screen (see **Setup Menu** on page 13).

NOTE: Extron recommends using the **FPC Settings** link on the Login screen (see **figure 20** on page 22) to open the setup menu.

- D USB connectors** — This has no function in FPC 6000.
- E Audio output** — This has no function in FPC 6000.

F XTP/LAN/PoE input

NOTE: The FPC 6000 can be powered by either the provided PoE power injector or a 12 VDC, 3 A power supply (which must be purchased separately). Do not remotely power the touchpanel using an XTP device. Before connecting power to the FPC 6000, read the Attention notifications below.

- XTP input — Do not connect the FPC 6000 directly to an XTP source.
- LAN input — If you use the provided 12 VDC power supply, connect the FPC 6000 directly to the network using a twisted pair cable, terminated with an RJ-45 connector.
- PoE input — If you use the provided PoE power injector, connect the FPC 6000 to the power injector output and connect the power injector input to the LAN (see [figure 5](#), on the previous page).

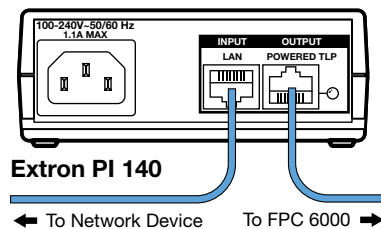

Figure 6. Connecting the Power Injector

ATTENTION:

- Always use a power supply provided by or specified by Extron. Use of an unauthorized power supply voids all regulatory compliance certification and may cause damage to the supply and the end product.
- Utilisez toujours une source d'alimentation fournie ou recommandée par Extron. L'utilisation d'une source d'alimentation non autorisée annule toute conformité réglementaire et peut endommager la source d'alimentation ainsi que le produit final.
- The installation must always be in accordance with the applicable provisions of National Electrical Code ANSI/NFPA 70, article 725 and the Canadian Electrical Code part 1, section 16.
- Cette installation doit toujours être en accord avec les mesures qui s'applique au National Electrical Code ANSI/NFPA 70, article 725, et au Canadian Electrical Code, partie 1, section 16.
- These products are intended for use with a UL Listed power source marked "Class 2" or "LPS" and rated 12 VDC, minimum 3.0 A. or 56 VDC (PoE), minimum 0.8 A.
- Ces produits sont destinés à une utilisation avec une source d'alimentation listée UL avec l'appellation « Classe 2 » ou « LPS » et normée 12 Vcc, 3,0 A minimum ou 56 Vcc (PoE), 0,8 A minimum.
- The power supply shall not be permanently fixed to the building structure or similar structure.
- La source d'alimentation ne devra pas être fixée de façon permanente à une structure de bâtiment ou à une structure similaire.
- Power over Ethernet (PoE) is intended for indoor use only. It is to be connected only to networks or circuits that are not routed to the outside plant or building.
- L'alimentation via Ethernet (PoE) est destinée à une utilisation en intérieur uniquement. Elle doit être connectée seulement à des réseaux ou des circuits qui ne sont pas routés au réseau ou au bâtiment extérieur.

ATTENTION:

- The touchpanels are intended for connection to a Power over Ethernet circuit for intra-building use only and are considered to be part of a Network Environment 0 per IEC TR62101.
- Les écrans tactiles sont conçu pour une connexion à un circuit PoE pour une utilisation intérieure seulement et est considéré comme faisant partie d'un environnement réseau 0 par IEC TR62101.
- Unless otherwise stated, the AC/DC adapters are not suitable for use in air handling spaces or in wall cavities. The power supply is to be located within the same vicinity as the Extron AV processing equipment in an ordinary location, Pollution Degree 2, secured to the equipment rack within the dedicated closet, podium, or desk.
- Sauf mention contraire, les adaptateurs AC/DC ne sont pas appropriés pour une utilisation dans les espaces d'aération ou dans les cavités murales. La source d'alimentation doit être située à proximité de l'équipement de traitement audiovisuel dans un endroit ordinaire, avec un degré 2 de pollution, fixé à un équipement de rack à l'intérieur d'un placard, d'une estrade, ou d'un bureau.
- Extron power supplies are certified to UL/CSA 60950-1 and are classified as LPS (Limited Power Source). Use of a non-LPS or unlisted power supply will void all regulatory compliance certification.
- Les sources d'alimentation Extron sont qualifiées UL/CSA 60950-1 et sont classées LPS (Limited Power Source). L'utilisation d'une source d'alimentation non-listée ou non-listée LPS annulera toute certification de conformité réglementaire.
- The length of the exposed wires in the stripping process is critical. The ideal length is 3/16 inches (5 mm). If they are any longer, the exposed wires may touch, causing a short circuit between them. If they are any shorter, the wires can be easily pulled out even if tightly fastened by the captive screws.
- La longueur des câbles exposés est primordiale lorsque l'on entreprend de les dénuder. La longueur idéale est de 5 mm (3/16 inches). S'ils sont un peu plus longs, les câbles exposés pourraient se toucher et provoquer un court circuit. S'ils sont un peu plus courts, ils pourraient sortir, même s'ils sont attachés par les vis captives.
- Do not tin the wire leads before installing into the connector. Tinned wires are not as secure in the connector and could be pulled out.
- Ne pas étamer les conducteurs avant de les insérer dans le connecteur. Les câbles étamés ne sont pas aussi bien fixés dans le connecteur et pourraient être retirés.

- G HDMI input** — This has no function in FPC 6000.
- H Mounting notches** — Used to attach the mounting plate to the FPC 6000
- I 12 VDC power supply input** — If you are not using Power over Ethernet, connect a 12 VDC, 3.0 A power supply to this captive screw connector. The power supply must be purchased separately. Extron recommends the PS 1230 Limited Power Source (LPS).
- J Mounting screws** — Used to secure the mounting plate to the FPC 6000.

Setup Menu

The setup menu allows initial configuration of the FPC 6000.

Setup Menu

To open the setup menu, press the **FPC Settings** link at the bottom of the **Login** screen (see [figure 20](#) on page 22), which appears when the FPC 6000 is powered on. Alternatively, press one of the **Menu** buttons, which are found on the rear panel (see [figure 5](#), **C** on page 10) or under the front panel (see [figure 4](#), **G** on page 9). Use a small screwdriver to press the button.

The menu opens at the **Status** screen. There are five navigation buttons in the panel at the top of the screen. These open the following screens:

- **Status** (see below)
- **Network** (see the following page)
- **Display** (see page 16)
- **Audio** (see page 17)
- **Advanced** (see page 18)

The screens are selected by pressing the appropriate button in the navigation panel at the top of the screen. The button for the selected screen is yellow. The buttons for the remaining screens are black.

There is also a red **Exit** button in the top right corner of the screen. Pressing this button applies and saves any changes and closes the menu screens.

Status

Press the **Status** button in the navigation panel at the top of any screen to open the **Status** screen.

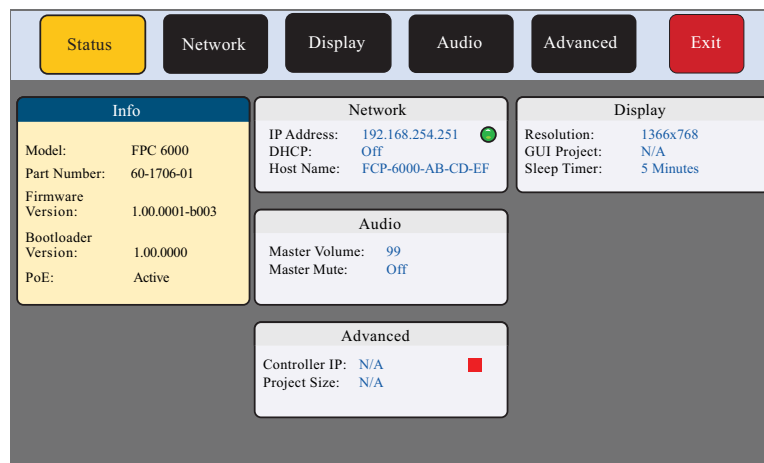

Figure 7. Status Screen

The **Status** screen is a read-only screen that provides basic information about the touchpanel. Each of the other four panels shows a summary of the information on the other screens. Pressing any of the panels opens the corresponding screen in the same way as pressing the buttons in the top navigation panel.

A green bubble in the **Network** panel lights when there is a network connection. A red square appears if there is no connection. The FPC does not require a control processor, and a red square appears next to the Controller IP to show that none is connected.

Network

Verify with your network administrator whether the IP address for the touchpanel is assigned by DHCP or set manually. If it is set manually, you need to obtain an IP address, a subnet mask, a gateway address, and a Domain Name Server (DNS) address (if needed) from the network administrator.

Press the **Network** button in the navigation panel at the top of the screen to open the **Network** screen.

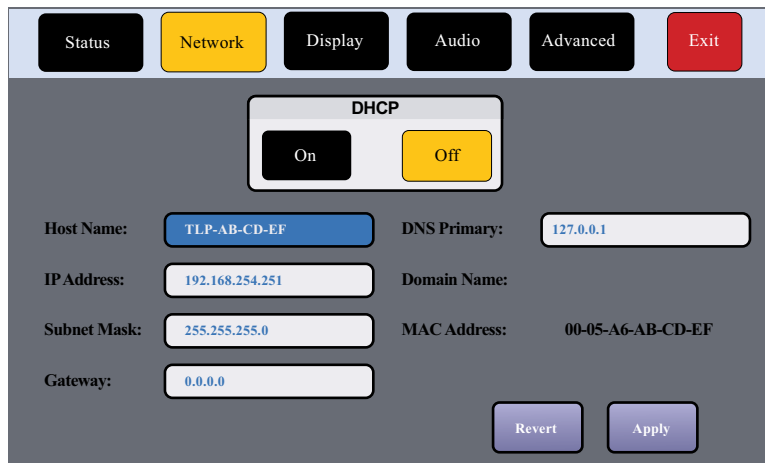

Figure 8. Network Screen

- If IP addresses are assigned by DHCP, press **On**. The selected button is highlighted in yellow.
 - When DHCP is off, the **Host Name** button is grayed out and host name cannot be edited. All addresses can be edited (as shown in figure 8).
 - When DHCP is on, the host name can be edited. The addresses are grayed out and cannot be edited because they are set by the DHCP server.

If IP addresses are assigned manually, press **Off**.

- If DHCP is on, you can edit the host name by pressing that button. A keypad opens:



Figure 9. Alphanumeric Keypad

- Use the keypad to enter a new name, which appears in the **Host Name** text box.
- Use the backspace character (**X**) to delete existing characters.
- The right and left arrows move the cursor inside the **Host Name** text box.
- Click the **Shift** key to toggle between upper and lower case letters.
- Press **Enter** to save the new name.

3. If DHCP is off, set the unit IP address, subnet mask, gateway address, and DNS server address.
 - a. Press the button for the address to be edited. A screen opens, showing the address and a numerical keypad.

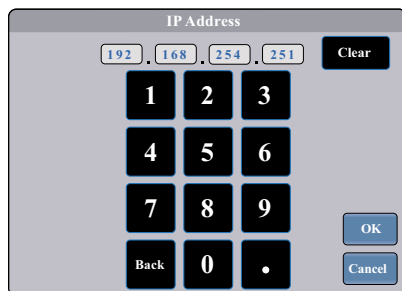

Figure 10. Numeric Pad for Setting IP Addresses

- b. Press **Clear** to remove the old address. If you start typing without pressing **Clear**, the first octet is over-written and the other octets remain the same.
 - c. Press any octet button to highlight and start editing it.
 - d. Enter the 3-digit value for that octet (leading zeroes in the octet are ignored).

NOTE: Octets can have any value between 0 and 255. If you attempt to enter an invalid number, for example 892, you are able to enter the 89 but the 2 cannot be entered.

Press **Back** to delete the last digit. If no value has been entered for the selected octet, pressing **Back** moves the cursor back to the previous octet.

- e. Press the next octet button and enter a value.
 - f. Repeat steps **c** through **e** until values have been entered for all four octets.
 - g. Press **OK** to save the changes and return to the **Network** screen or press **Cancel** to return to the **Network** screen without saving the changes.
4. If you have changed any of the values in the **Network** screen, the background color of the button changes to blue. Press **Apply** to apply the new values or press **Revert** to return to the previous values without saving the changes. 0.0.0.10

If you have not made any changes, the **Apply** and **Revert** buttons are grayed out.

Display

Press the **Display** button in the navigation panel at the top of the screen to open the Display screen.

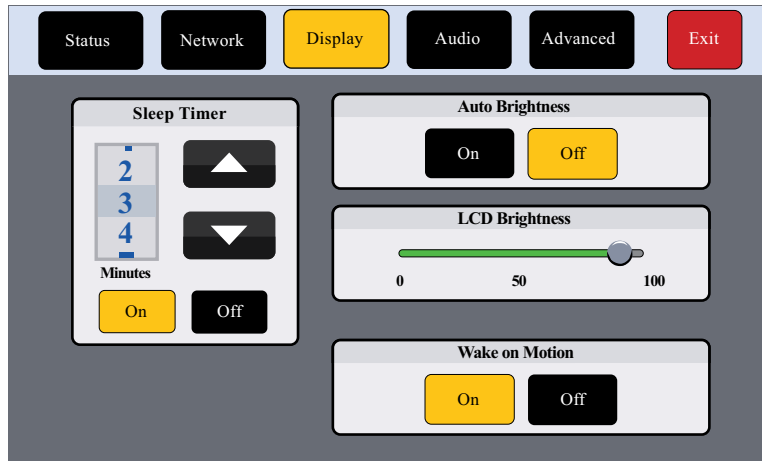

Figure 11. Display Screen

The Display screen allows you to set the Sleep Timer, Auto Brightness, LCD Brightness, and Wake on Motion.

- **Sleep Timer** — Determines how long the panel is inactive before it enters sleep mode, when the screen goes dark to save power. Toggle between **On** and **Off**. If the sleep timer is on, use the arrows to adjust the value between 1 and 120 minutes.
- **Auto Brightness** — Provides a suitable amount of backlighting that is automatically calculated from the amount of ambient light detected by the light sensor (see [figure 4](#), © on page 9).
- **LCD Brightness** — Allows you to adjust the screen brightness, using the slider control.
- **Wake on Motion** — Activates the panel from Sleep mode when motion is detected near the unit. Toggle between **On** and **Off**.

Audio

Press the **Audio** button in the navigation panel at the top of the screen to open the **Audio** screen.

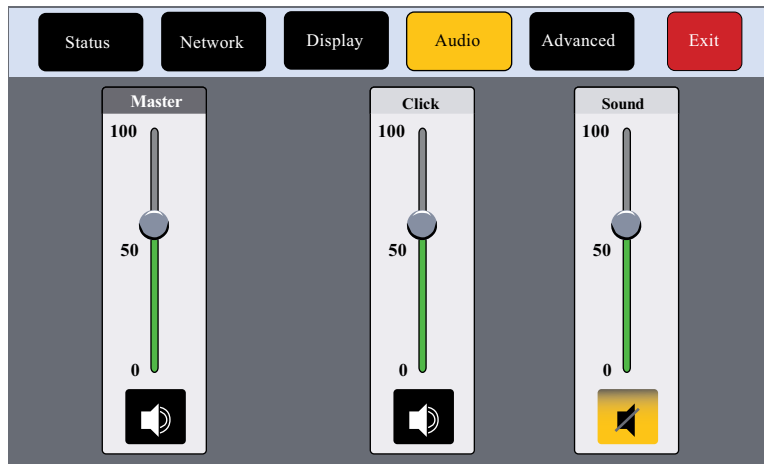

Figure 12. Audio Screen

On the **Audio** screen, use the **Master**, **Click**, and **Sound** slider controls to adjust the volume settings.

- **Master** — Sets the maximum volume for all the other sound volume settings. For example, if the master volume is set to 80 (80 percent of maximum), even when the sound volume is set to 100, it is equivalent to only 80 percent of maximum.
- **Click** — Sets the volume for audible feedback that accompanies events such as a screen button being pressed.
- **Sound** — Sets the volume of audio from any audio file playback.

Click on the **Speaker** icon at the bottom of each panel to toggle between audio on and audio mute. The **Sound** audio is muted in figure 12.

Advanced

Press the **Advanced** button in the navigation panel at the top of the screen to open the Advanced screen.

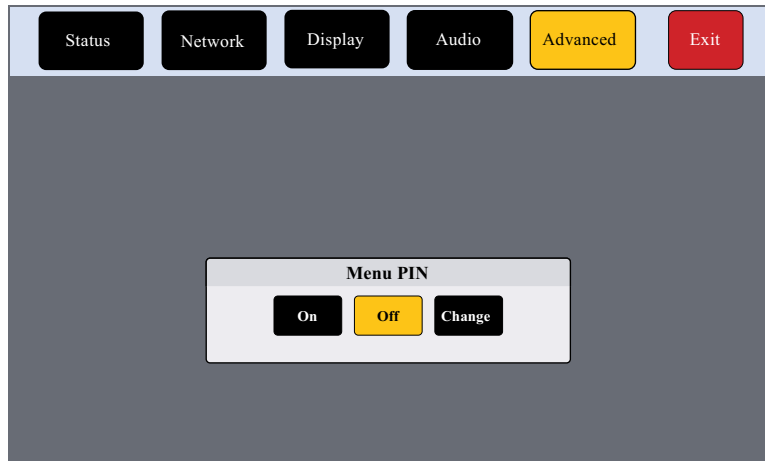

Figure 13. Advanced Screen

Menu PIN

The PIN setup options allow you to enable, disable, or change the setup menu PIN. The PIN is a four-digit number. Each digit can have any value from 0-9.

If the PIN is enabled, users need to enter the number to access the setup menu pages.

1. Select the first digit of the PIN. When selected, it is highlighted in yellow.



Figure 14. Numeric Keypad for Setting PIN

2. Press a number on the keypad. That number appears in the PIN.
3. Repeat steps 1 and 2 for the other three digits.
4. The title bar changes to **Confirm New Menu Pin**.
5. Enter the PIN a second time. When the PIN entered on the second occasion matches the PIN entered on the first occasion, the PIN is set and the dialog closes.

FPC 6000 Web Page

This section of the user guide provides information about:

- [FPC 6000 Web Page](#)
- [Updating the Firmware](#)

FPC 6000 Web Page

To access the FPC 6000 embedded web page, enter the IP address of the unit into the web browser of a PC connected to the same subnet. A dialog box opens asking for your user name (by default this is `admin`) and password.

NOTES:

- The factory configured passwords for all accounts on this device have been set to the device serial number. Passwords are case sensitive.
- If the device is reset to default settings, the password will be the default password configuration. The default password is `extron`.
- To change the password, you must use the Extron Toolbelt utility (see the *Toolbelt Help File*). Talk to your Extron rep about obtaining a license for Toolbelt.

A single, read-only page provides general and network information about the unit (see figure 15, below). It also allows you to upgrade the unit firmware. Use the [Setup Menu](#) (see page 13) to configure the touchpanel network settings.

The screenshot displays the FPC 6000 web interface. At the top, it identifies the device as 'FPC 6000 15" Matrix Control Panel' with firmware version 'v0.00.0000'. The user is logged in as 'admin'. The interface is divided into two main sections: 'General Status' and 'LAN'. The 'General Status' section provides details such as Model Name, Description, Part Number, Firmware Version, Date, Time, PoE status, and Up Time. The 'LAN' section shows network configuration including DHCP status, Host Name, IPv4 IP Address, Subnet Mask, Gateway IP, DNS(IP), and MAC Address. At the bottom, there is a 'Firmware Uploader' section with a file input field and 'Browse' and 'Upload' buttons. The footer indicates '© Extron Electronics 2018'.

General Status	
Model Name:	FPC 6000
Description:	15" Matrix Control Panel
Part Number:	60-1706-01
Firmware Version:	0.00.0000-b021_BR_DEV
Date:	March 26, 2018
Time:	4:13 PM
PoE:	Active
Up Time:	0 day(s) 3 hour(s) 43 minute(s)

LAN	
DHCP:	Off
Host Name:	FPC-6000-AD-AD-AD
IPv4 IP Address:	192.168.250.250
Subnet Mask:	255.255.255.0
Gateway IP:	0.0.0.0
DNS(IP):	127.0.0.1
MAC Address:	00-05-A6-AD-AD-AD

Figure 15. FPC 6000 Web Page

Updating the Firmware

Firmware for the FPC 6000 can be upgraded using the touchpanel web page. Before starting, consult your IT team and ensure that the touchpanel has a unique IP address.

Downloading Firmware

1. Power on a computer that is connected to the same network as the touchpanel.
2. On the Extron website (www.extron.com), click **Download** in the menu bar along the top of the page (see figure 16, **1**).
3. Click **Firmware** in the menu bar in the left side bar (**2**).

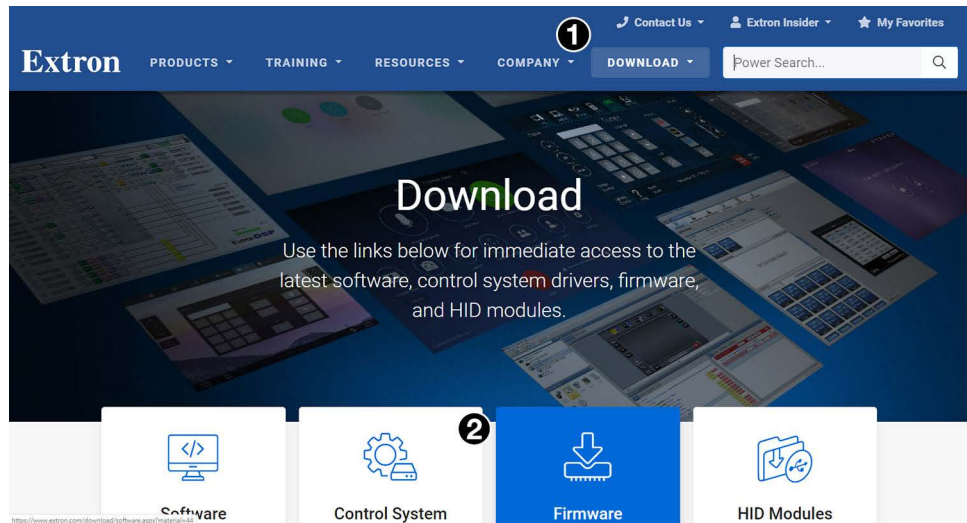

Figure 16. Firmware Download Center

4. The Firmware Download Center opens. Click the letter **F** from the alphabet menu (see figure 17, **1**).

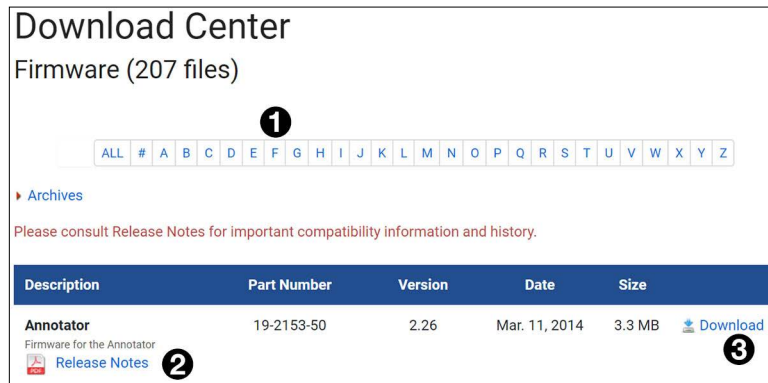

Figure 17. Firmware Download Center

5. Scroll down the page until you find the firmware for the FPC 6000.
6. Click **Release Notes** (**2**) for more information about the firmware (optional).
7. Click **Download** (**3**).
8. Enter the required information in the form that opens.
9. Press the download button. An executable (.exe) file is downloaded to your computer. Run this program to place the firmware on your computer for future use. Make a note of the folder where the firmware is saved.

Updating Firmware Using the Touchpanel Web Page

1. If you have not already done so, download the firmware file to a computer on the same network as the touchpanel (see the previous section).

NOTE: Firmware files must have a .eff extension.

2. Open the [FPC 6000 Web Page](#) (see page 19).



Figure 18. Touchpanel Web Page: Firmware Uploader Pane

3. Click **Browse**.
4. In the dialog box that opens, navigate to the firmware location and select the file.
5. Click **Upload**. The firmware file is uploaded to the touchpanel.

The upload takes a few minutes. A series of popup screens provide information about the progress of the firmware update:

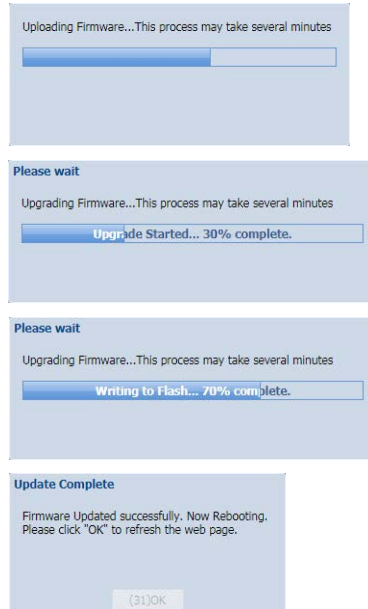

Figure 19. Popup Screens from Firmware Update

When the update is complete, the FPC 6000 reboots and the login screen is shown. You need to log in to the controller once again (see [Login Screen](#) on page 22).

6. Click **OK** to refresh the web page. You also need to log in to the web page once again (see [FPC 6000 Web Page](#) on page 19).

Operation

The FPC 6000 is a touchscreen interface that allows the user to control, monitor, access, and manage a range of Extron matrix switchers via a direct connection or over a local area network. Two or more FPC units connected to the network allow the matrix switcher to be controlled from multiple locations.

This section of the guide describes the front panel login screen and how to use the four main screens:

- **Login Screen**
- **Ties Screen**
- **Status Screen**
- **I/O Info Screen**
- **Customize Screen**

The login screen allows you to connect with a FOX matrix switcher over a LAN. The other screens allow you to control and monitor the switcher.

Login Screen

When the FPC 6000 is powered on, it opens to the **Log in** screen.

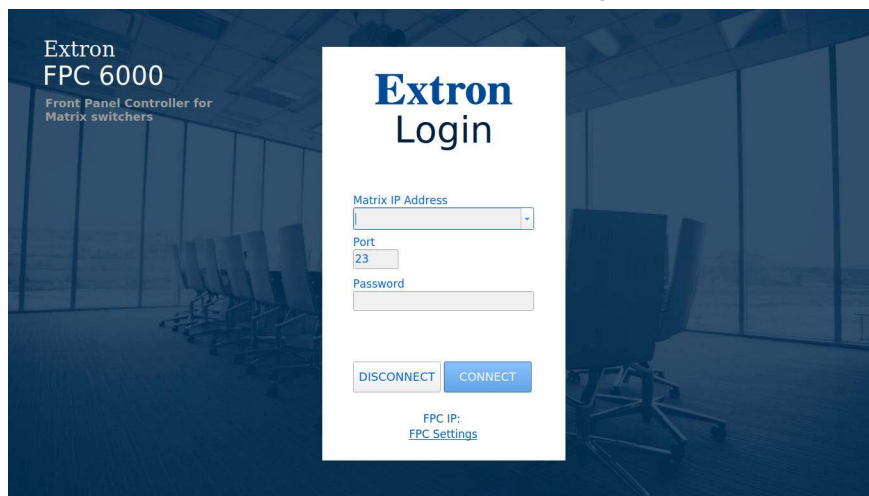

Figure 20. FPC Login Screen

1. Tap the **Matrix IP Address** text box to activate it.
An on-screen keyboard opens:



Figure 21. Keyboard

2. Use the **up** arrow key (see figure 21, ❶) to toggle between upper or lower case letters. Use the numbers key (. ?123, ❷) to toggle between letters or special characters and numbers. Use the **keyboard** key (🗂️) to hide the keyboard.
3. If necessary, clear existing characters by pressing the text box to the right of the final character, and then repeatedly pressing the **backspace** key (⌫) until all unwanted characters are removed.
4. Press the **numbers** key and use the keyboard to enter the IP address of the matrix switcher.

NOTE: If you have previously connected to a matrix switcher, the IP address might already be displayed or may be available in the dropdown menu.

5. When you have entered the IP address, press the **Port** text box to enter a value. If necessary, press the **numbers** key. Enter the number of the port used to communicate with the matrix switcher. This is usually 23.
6. If required, press the **Password** text box and use the on-screen keyboard to enter the user name (by default this is **admin**) and password for the matrix switcher.

NOTES:

- The factory configured passwords for all accounts on this device have been set to the device serial number. Passwords are case sensitive.
- If the device is reset to default settings, the password is the default password configuration. The default password is **extron**.
- To change the password, you must use the Extron Toolbelt utility (see the *Toolbelt Help File*). Talk to your Extron rep about obtaining a license for Toolbelt.

7. Press **Submit**.

The FPC 6000 attempts to connect to the matrix switcher. If successful, the **Ties Screen** appears (see **figure 23** the next page).

If the FPC 6000 cannot connect to the matrix switcher, an error message appears:

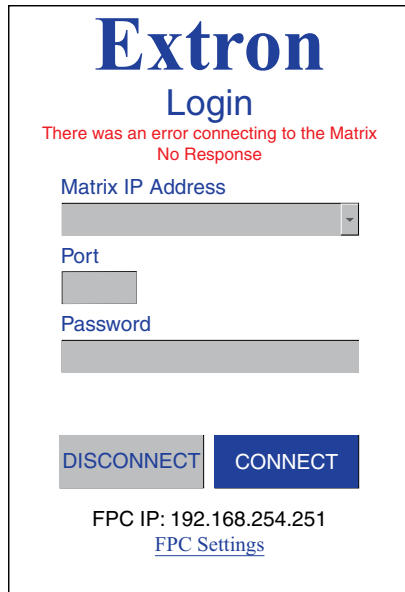

Figure 22. Error Connecting to Matrix

8. Verify that you have the correct IP address and password before reentering the values.

Ties Screen

After successfully logging in, the Ties screen opens.



Figure 23. Ties Screen

- A Menu Buttons** (see the next page)
- F Mute Selection Buttons** (see page 26)
- B Input Buttons** (see the next page)
- G Mute Control Button** (see page 26)
- C Change View** (see page 30)
- H Take** (see page 26)
- D Output Buttons** (see the next page)
- I Select All** (see page 26)
- E Presets** (see page 32)
- J Clear Selection** (see page 26)

NOTE: The number of input and output buttons that are available reflects the number of inputs and outputs on the matrix switcher to which the FPC 6000 is connected.

Menu Buttons

The FPC 6000 has five screens: the Connect (login) screen and four main screens. These are **Ties**, **Status**, **I/O Info**, and **Customize**. Five menu buttons on the left side of the screen (see [figure 23, A](#), on the previous page) allow you to navigate to the desired screen by pressing the appropriate button. These buttons are available on all FPC 6000 screens, and the currently selected button has a colored edge.

NOTE: When the **Ties** screen is selected, the button is renamed **TIES/Refresh**. In all other screens, it is named **TIES**.

Input Buttons

The screen has two blocks of numbered buttons. The buttons on the left correspond to the matrix switcher inputs. The buttons on the right correspond to the matrix switcher outputs.

Before you make any ties, the input buttons (see [figure 23, B](#)) have a gray rectangle in the top right corner. The number in that rectangle corresponds to the number of the input on the switcher. When an input is selected, the color of the button changes to blue (see input 1 in figure 23). If the input has an active source, the color of the rectangle changes to blue (compare input 2 and input 3).

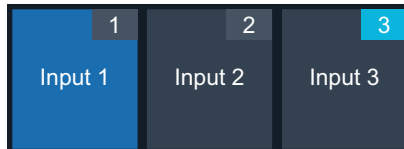

Figure 24. Input Buttons

The button also contains the name of the input. By default, this is **Input XXX**, where **XXX** is the same as the number in the top right corner of the button. Buttons can be renamed using Simple Instruction Set (SIS) commands (see the matrix switcher user guide for instructions).

The FPC 6000 screen shows 20 inputs at a time. Use the scroll bar to the right of the inputs to navigate through all the inputs that are available with your matrix switcher.

NOTES:

- When selected, the button lights.
- After 30 seconds with no front panel activity, all buttons time out.
- After 3 minutes with no front panel activity, the panel enters power saving mode. The touchpanel becomes active again when it detects motion in front of the screen.

Output Buttons

Before you make any ties, the output buttons (see [figure 23, D](#)) have a gray rectangle in the top right corner. The number in that rectangle corresponds to the number of the output on the switcher. When you select an output the button lights. If the output is tied to an input, the corresponding input button also lights.

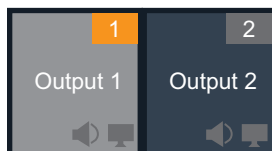

Figure 25. Selected (output 1) and Unselected (output 2) Outputs

The button also contains the name of the output. By default, this is **Output XXX**, where **XXX** is the same as the number in the top right corner of the button. Buttons can be renamed using SIS commands (see the matrix switcher user guide for instructions).

The FPC 6000 screen shows 20 outputs at a time. Use the scroll bar to the right of the outputs to navigate through all the outputs that are available with your matrix switcher.

The button also provides information about the mute status of the output (see figure 26, below). Use the **Mute/Unmute** button (see [figure 23](#), **G**, on page 24) to change the mute status of an output that has been selected.

NOTES:

- When selected, the button lights.
- After 30 seconds with no front panel activity, all buttons time out.
- After 3 minutes with no front panel activity, the panel enters saving mode. The touchpanel becomes active again when it detects motion in front of the screen.

Mute Selection Buttons

These buttons (see [figure 23](#), **F**, on page 24) are designed to work with matrix switchers that allow audio breakaway. The user can decide to mute both audio and video at the same time (AV), video only (V), or audio only (A).

At present, the FPC 6000 works with only FOX matrix switchers, which do not allow audio breakaway. The only option is AV (both audio and video muted or unmuted together). The other buttons are placeholders that will function when additional matrix switchers become available for control by the FPC 6000.

Mute Control Button

When you select an output button, the mute control button (see [figure 23](#), **G**, on page 24) becomes active. This button allows you to mute both the video and audio being sent to the selected output.

When you mute the audio and video, the output button shows a diagonal line through the audio and video icons (compare unmuted output 1 and muted output 2 in figure 26).



Figure 26. Unmuted and Muted Output

Select All

To create potential ties from a selected input to all outputs, press **Select All** (see [figure 23](#), **I**). For the ties to go into effect, press the **Take** button.

NOTE: When you select an input and press **Select All**, the **Mute** button is renamed to become the **Take** button and the button that was labelled **Take** is renamed to become the **Break** button.

Take

When you link an input and an output, using the **Ties** screen, you create a potential tie. For the tie to go into effect, press the **Take** button (see [figure 23](#), **H**).

Break

This button is not available on the default screen. It only becomes available when you select an input and press **Select All**.

Press **Take** to form ties between the selected input and all outputs. Or press **Break** to break all previously existing ties to the selected input.

Clear Selection

Ties created on this screen do not go into effect until they are saved by pressing **Take**. To undo ties before they have been saved, press the **Clear Selection** button (see [figure 23](#), **J**).

Create a Tie

NOTE: At present, the FPC 6000 works with only FOX matrix switchers. With these matrix switchers, there is no audio breakaway: only AV ties are formed (audio signals are always associated with video signals).

1. Press the desired input button. The selected input button lights. Any outputs that are already tied to that input also light.



Figure 27. Creating a Tie: Select Input

In figure 27, input 186 is already tied to outputs 121 and 128.

2. Press one or more output buttons. The selected output buttons light and a plus sign appears in the bottom right corner. The **Take** button on the right of the screen becomes available, as indicated by the orange band along the right edge of the button.



Figure 28. Creating a Tie: Select One or More Outputs

In figure 28 a potential tie has been created between input 186 and output 115.

NOTE: You can also tie an input to all outputs by pressing the **Select All** button (see page 29).

- To make permanent the potential tie created in step 2, press the **Take** button. This saves the changes that you have made.

Progress in saving the selection is shown in a bar that appears at the top of the screen.

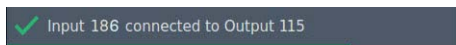

Figure 29. Progress Bar

ATTENTION:

- If an output was previously tied to a different input, the old tie is overwritten, without a warning.
- Si une sortie était précédemment liée à une autre entrée, l'ancienne liaison est remplacée sans avis préalable.

NOTES:

- One input can be tied to multiple outputs but each output can be tied only to a single input.
- Press the **Clear Selection** button to clear a tie before the changes have been made.
- When you have selected an input, you can press the **Select All** button to tie all the outputs to that input.

Break A Tie

To break an existing tie, follow these steps:

1. Press the desired input button. The selected input button and any outputs that are already tied to it light (see [figure 27](#) on the previous page).
2. Press one or more buttons for tied outputs that you wish to break.

A minus sign appears in the bottom right corner of the selected output button and the **Take** button becomes active.

In figure 30, input 186 has existing links to outputs 115, 121, and 128. Output 115 has been selected to break its tie with input 186, as shown by the minus sign. Outputs 121 and 128 have not been pressed and the ties remain.



Figure 30. Breaking a Tie

3. Click **Take** to permanently break the tie between the input and selected outputs.

While the tie between input 186 and output 115 is broken, the progress bar (see figure 29) appears with the text **Output 115 disconnected**.

Alternatively, click **Clear Selection** to remove the selection without saving it.

After selecting an input, you can press **Select All**. You will then have two options:

- Press **Take** (see figure 31, ①), which ties the selected input to all outputs.
- Press **Break** (②), which breaks all ties to the selected input.



Figure 31. Select All Outputs

If you press **Break**, a warning dialog box opens:

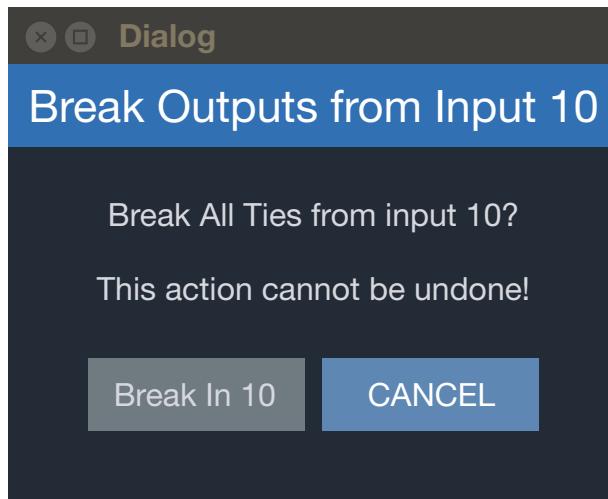

Figure 32. Break Ties Warning Dialog

Press **Break** to break the ties or **CANCEL** to keep the ties. The **Break** button counts down in seconds. If neither button is pressed after 10 seconds, the request is cancelled and the ties are broken.

Change View

The **Ties** screen default view shows 20 input and output buttons at the same time. You can use the scroll bar to navigate through all the inputs and outputs on the matrix switcher.

Sometimes it may be more convenient to work with the inputs or outputs individually. Clicking **Change View** allows you to toggle between the default view (with multiple buttons) and an alternative view.

Change View – inputs

Figure 33 shows the view when **Change View** for inputs (1) is pressed.

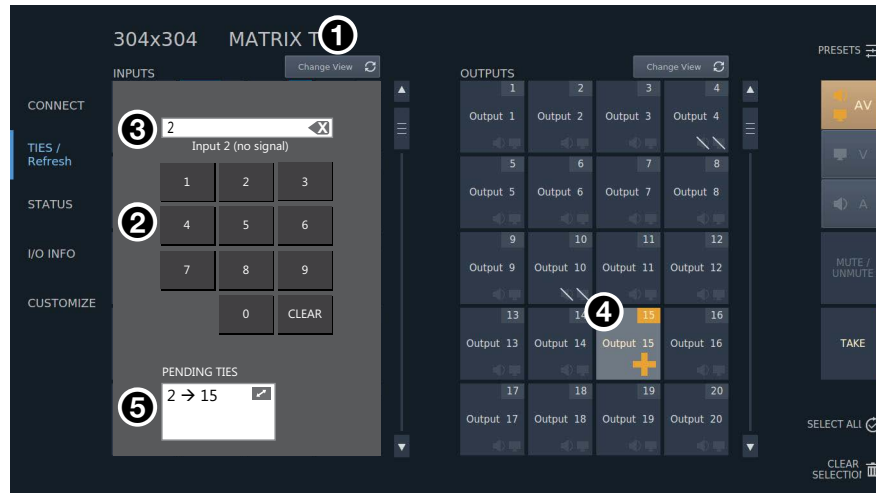

Figure 33. Change View – Inputs

1. Use the keypad (2) to enter the value of the input.

The number appears in the top text box (3) and the name given to the input appears underneath.

NOTE: If the value entered in the top text box is greater than the number of inputs available on the switcher, the message **OUT OF RANGE** appears below the text box. Press **Clear** and reenter the number.

Any outputs that are already tied to that input light as they did in the default view.

2. Press the buttons for one or more outputs that you want to tie to that input.

The selected output buttons light up. A plus sign appears in the bottom right corner (4) and the tie is shown in the **Pending Ties** text box (5).

NOTE: The **Pending Ties** box does not show ties to the selected input that have already been saved.

3. If the the number of pending ties exceeds the space in the text box, scroll bars appear in the text box. You can also press the button in the top right corner (🗒) to expand the box (see figure 34).
4. Press **Take** to save the ties.

The progress bar (see [figure 29](#) on page 28) appears as the changes are saved.

To return to the default view, press **Change View** again.

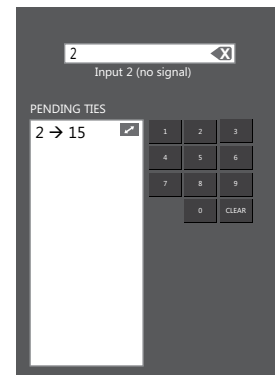

Figure 34. Expanded Pending Ties Box

Change View – outputs

Figure 35 shows the view when **Change View** for outputs (1) is pressed.

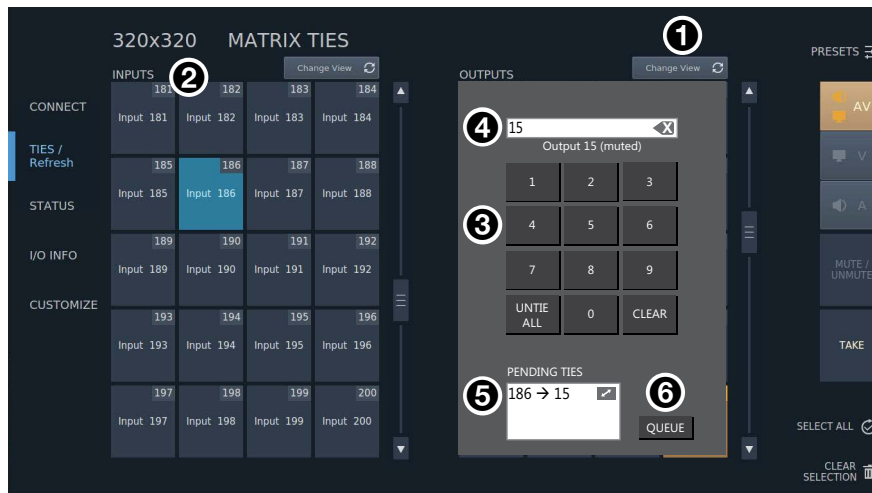

Figure 35. Change View – Outputs

1. Select an input button (2).
2. Use the keypad (3) to enter the value of the output.
3. The number appears in the top text box (4).

The output number and the mute status for that output is shown below the text box.

NOTE: If the value entered in the top text box is greater than the number of outputs available on the switcher, the message **OUT OF RANGE** appears below the text box. Press **Clear** and reenter the number.

Continue entering the ties, one at a time. The pending ties are listed in the **Pending Ties** box (5). You can have multiple pending ties listed at once.

Once a tie has been set up, the **Queue** button (6) appears.

4. Press either the **Queue** button or the **Take** button to save the changes.

The progress bar (see [figure 29](#) on page 28) appears as the changes are saved.

NOTE: You can configure ties with both the **Change View** (inputs) and **Change View** (outputs) open at the same time.

Presets

The configuration that is currently being used by the matrix switcher is the current configuration (or Configuration 0). Extron matrix switchers allow you to save commonly used configurations as presets, which can be recalled. Once they are recalled, they become the current configuration, replacing the configuration that was being used.

Global and room presets

There are two types of presets:

- Global memory preset
- Room memory preset

Global memory preset

When a configuration is stored as a global memory preset, all active inputs and the outputs tied to them are saved. The number of global presets supported depends on the matrix switcher model. FOX 3200 models support up to 32 global presets. Other FOX models support up to 64 global presets. When a global preset is retrieved from memory, it becomes the current configuration.

Room memory preset

A room consists of a small subset of virtual outputs that are logically related to each other. They do not have to be literally in the same room. They are grouped together for the convenience of the operator.

Rooms and room presets can be recalled but cannot be created with the FPC 6000. They must be created by SIS commands sent from a PC to the switcher (see the user guide for your matrix switcher).

- Depending on the model, Extron matrix switchers can support up to 10 rooms.
- Each room can have 1 to 16 virtual outputs.
- Each room can have up to 10 presets.

A room preset consists of virtual outputs in a single room that have been stored. When a room preset is retrieved from memory, it becomes the current configuration.

Saving presets

Rooms and room presets must be saved using SIS commands (see the matrix switcher user guide for instructions).

To save a global preset follow these instructions:

1. Create one or more sets of ties (see [Create a Tie](#) on page 27).
2. Open the **Presets** menu (see [figure 39](#) on page 35).
3. Press **Save As . . .**

The **Saving Preset** menu opens:

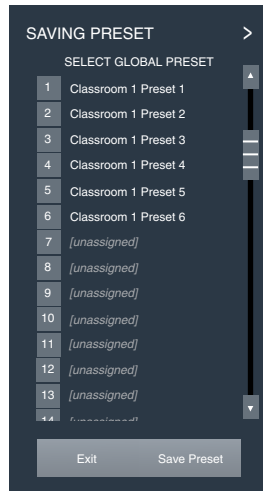

Figure 36. Saving Preset Menu

4. Select an **[unassigned]** preset.

A keyboard opens:



Figure 37. Saving Preset Keyboard

5. Press the keys to enter a name for the preset. The name appears in the text box above the keyboard.

Use the **up arrow** key for upper case letters or the **.?123** key for numbers and special characters. You can use any combination of upper case letters, lower case letters, numbers, and special characters.

NOTE: If you do not name the preset, the next available name from the series **Preset 1, Preset 2, etc.** is automatically assigned.

6. Press **Submit** on the keyboard or **Save Preset** in the **Saving Preset** menu. The preset is saved.

Overwriting an existing preset

To overwrite an existing preset, follow these instructions:

1. Create one or more sets of ties and open the **Saving Presets** menu as described in **steps 1-3** of the previous section.
2. Select one of the presets that has already been named and saved.
3. Press **Save Preset**.

A warning dialog box appears:

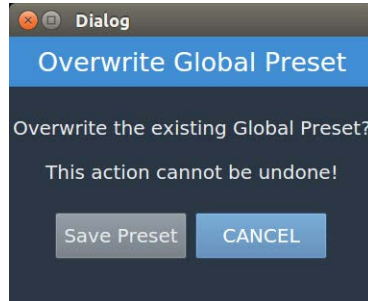

Figure 38. Overwrite Warning Dialog

4. Press **Save Preset** to save or **CANCEL** to exit without saving.

Recalling a global preset

1. To recall or save a preset, press the **Presets** button (see [figure 23](#), **E**, on page 24) on the right of the screen. The Presets menu opens.

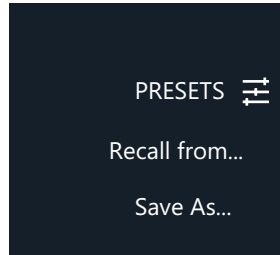

Figure 39. FPC 6000 Presets Menu

2. Press **Recall from...**

The **Recalling Preset** menu opens as a sidebar on the right of the screen with the global presets listed.

3. If required, press the **Global** tab (it is usually selected by default).

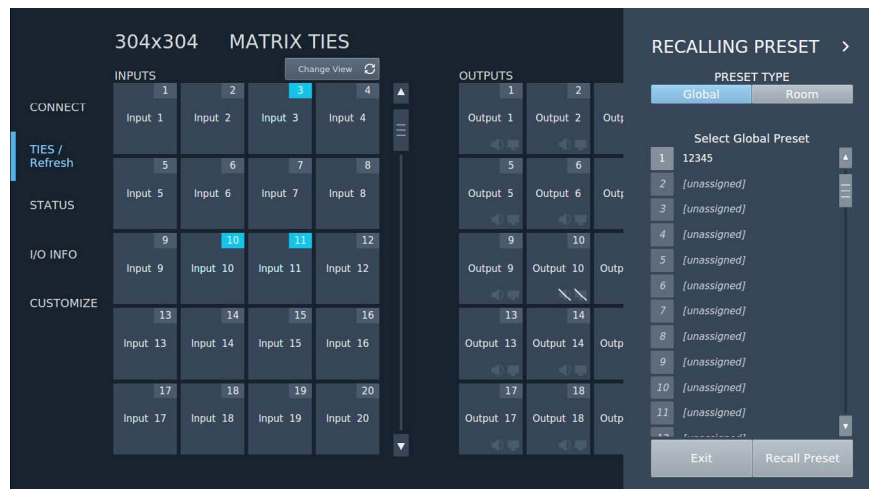

Figure 40. Recalling a Global Preset

4. Press the global preset that you want to recall.

Use the scroll bar to view the complete list.

NOTE: The number of global presets available depends on the matrix switcher model. See the user guide for your matrix switcher for complete information.

5. Press **Recall Preset**.

The progress bar (see [figure 29](#) on page 28) appears with the message **Global Preset X. *NNN* Successfully Recalled**, where *X* is the number of the Global Preset and *NNN* is the name assigned to the preset.

The configuration in the recalled preset becomes the current configuration.

Recalling a room preset

1. Open the Presets Menu (see [figure 39](#) on the previous page).
2. Press **Recall from...** The Recalling Preset menu opens.
3. Press the **Room** tab.

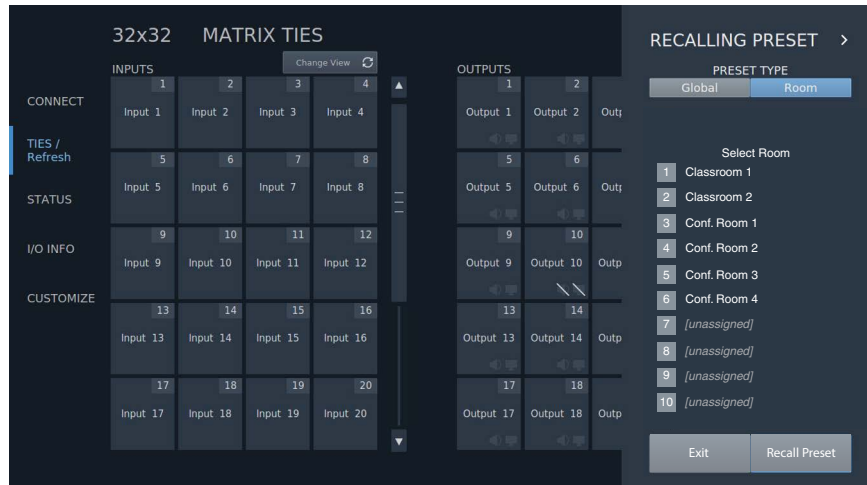

Figure 41. Selecting a Room

NOTE: Matrix switchers have ten rooms available.

4. Press a number to select the desired room.

The selected room is shown at the top of the column and the presets that are available for that room are listed beneath.

NOTE: Ten presets are available for each room.

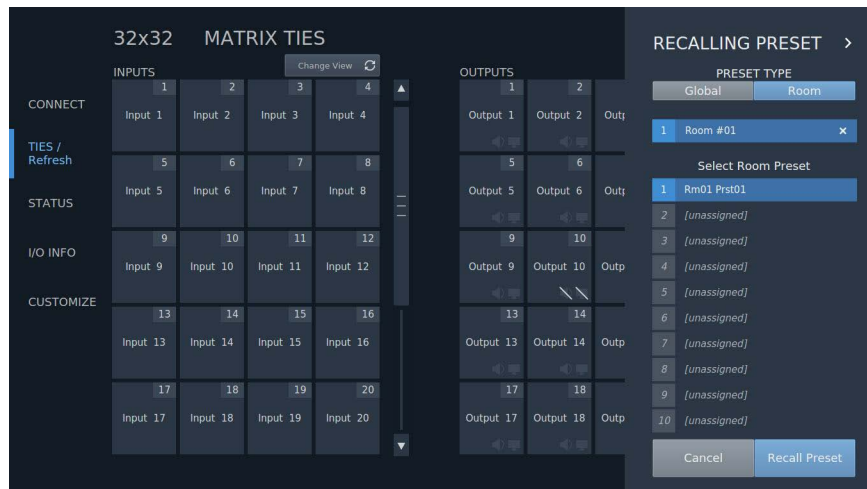

Figure 42. Recalling a Room Preset

5. Press a number to select the room preset.
6. Press **Recall Preset**.

The progress bar (see [figure 29](#) on page 28) appears with the message **Global Preset X. MWN Successfully Recalled**, where X is the number of the Global preset and MWN is the name assigned to the preset.

Status Screen

This screen is read-only. It provides information about status of the matrix switcher. Press **Status** in the menu bar on the left of the screen. The **Status** screen opens.

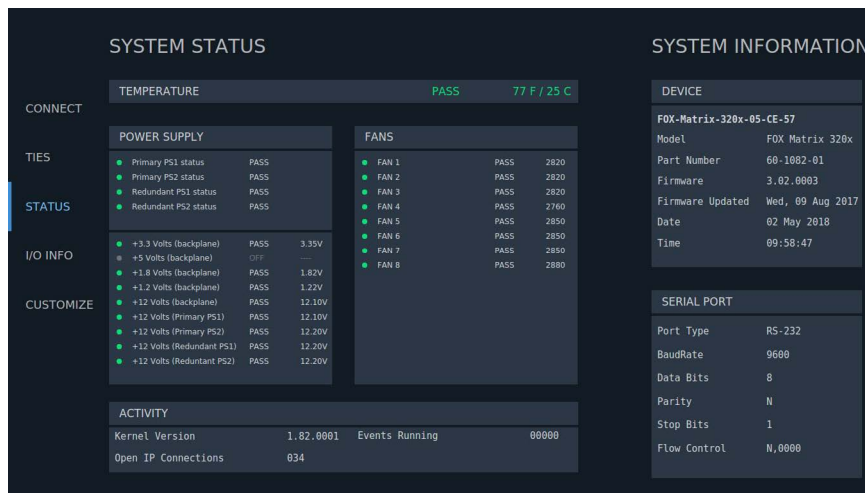

Figure 43. FPC 6000 Status Screen.

I/O Info Screen

The I/O Info screen allows you to find complete information about a single input or output. Press **I/O Info** in the menu bar on the left of the screen. The **I/O Info** screen opens with the **Inputs** tab selected.

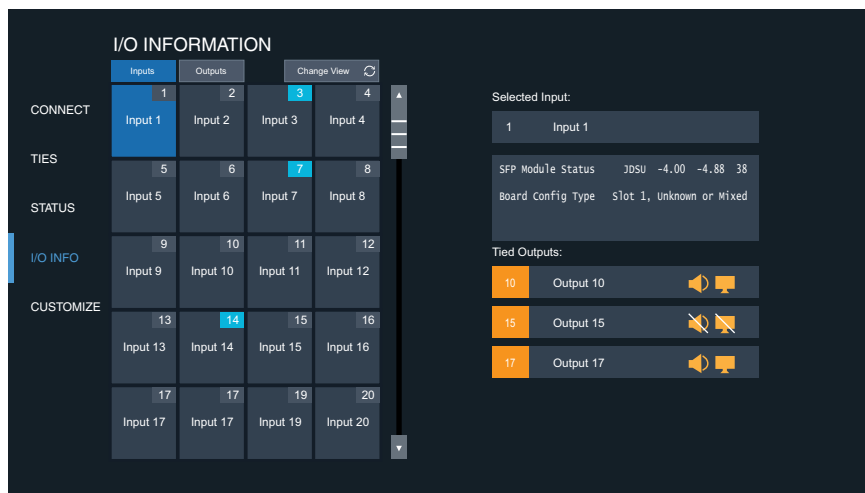

Figure 44. FPC 6000 I/O Info Screen (Inputs).

The inputs are organized in the same way that they are in the **Ties** screen.

From this screen, you can:

- Select an input by pressing an input button. When you press an input button, details about that input appear on the right side of the screen. If the input is tied to one or more outputs, that information is also shown.

In figure 44, input 1 is selected and it is tied to outputs 10, 15, and 17. The video and audio for output 15 are both muted.

- Press **Change View**. This allows you to enter a value for the input:



Figure 45. Entering an Input Using the Change View Screen

- View outputs by pressing the **Outputs** tab.

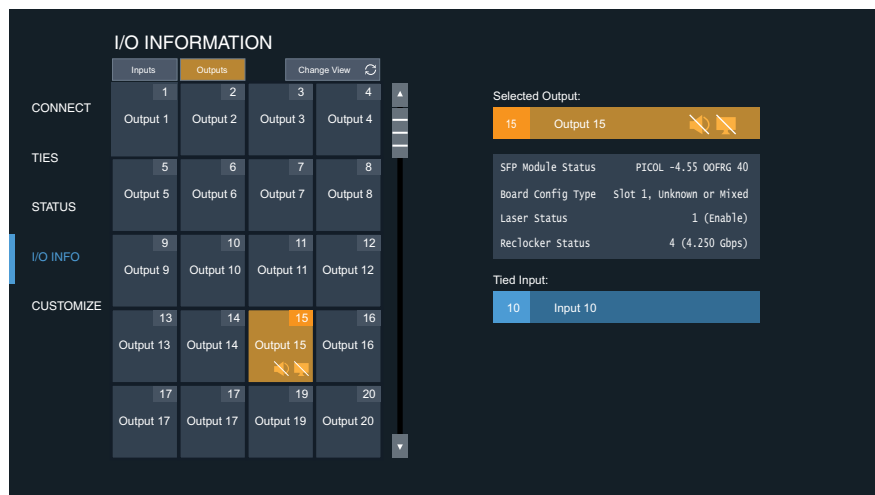

Figure 46. FPC 6000 I/O Info Screen (Outputs).

Select an output by pressing on an output button. When you press an output button, details about that output appear on the right side of the screen. If the output is tied to an input, that information is also shown.

In figure 46, output 15 is selected and it is tied to input 10. The video and audio for output 15 are both muted.

To enter an output manually, press **Change View**. A screen opens that is similar to figure 45, above.

Customize Screen

Press **Customize** in the menu bar on the left of the screen. The **Customize** screen opens.

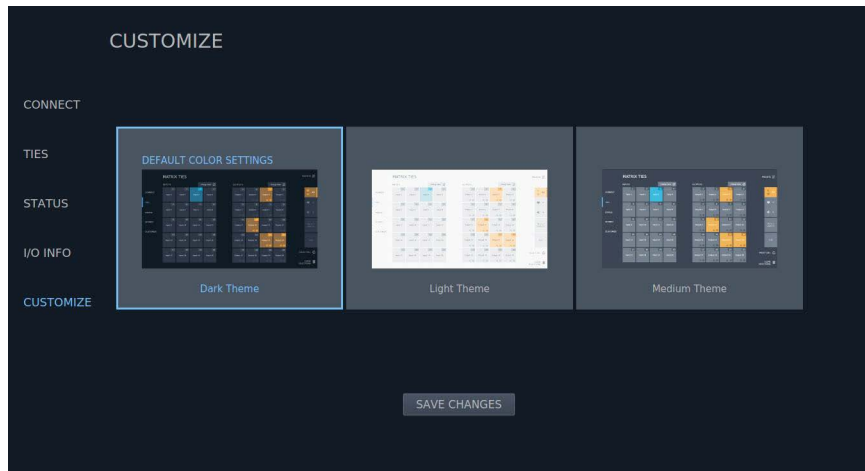

Figure 47. FPC 6000 Customize Screen.

On this screen you can change the appearance of the graphical user interface.

There are three options:

- **Dark Theme** (default)
 - **Medium Theme**
 - **Light Theme**
- 1.** Press the desired option. The selected option is highlighted in blue.
 - 2.** Press **Save Changes** to save the selection.

The FPC 6000 may take a few moments to update the screen view.

Reset Modes

The FPC 6000 has three reset modes that are initiated by pressing the **Reset** button:

- **Use Factory Firmware**
- **Reset All IP Settings**
- **Reset to Factory Defaults**

The **Reset** button is found on the rear panel (see [figure 5, B](#), on page 10).

Use Factory Firmware

This mode is used to boot up the unit with factory-installed firmware for a single power cycle in the event of a firmware update that failed or incompatibility issues arising with user-loaded firmware.

Activation

To start the Use Factory Firmware reset mode and replace firmware:

1. Remove power from the touchpanel.
2. On the touchpanel, hold down the recessed **Reset** button (see [figure 5, B](#)) while re-applying power to the unit. When power is restored, the **Reset** LED lights. Hold the **Reset** button for a further two seconds before releasing it. The touchpanel enters factory firmware mode.
3. Upload new firmware to the unit as desired (see [Updating Firmware Using the Touchpanel Web Page](#) on page 21).

NOTE: Do not continue to operate the touchpanel using the factory firmware version. If you want to use the factory default firmware, you must upload that version again.

Result

The unit reverts to factory-installed firmware. Event scripting does not start if the unit is powered on in this mode. All user files and settings such as drivers, adjustments, and IP settings are maintained.

NOTE: To return the unit to the firmware version that was running prior to the reset, cycle power to the unit.

The login screen opens with the message **Project Not Running**.

The FPC 6000 cannot be accessed from the front panel.

The FPC 6000 IP address has not been changed. Use a PC to open the FPC 6000 web page and install new firmware (see [Updating Firmware Using the Touchpanel Web Page](#)). Once the new firmware is installed, the FPC 6000 will function normally.

Reset All IP Settings

This mode resets all IP settings to factory defaults.

Activation

To reset all IP settings:

1. Hold down the **Reset** button for about 6 seconds until the Power LED blinks twice (once at 3 seconds and again at 6 seconds).
2. Release and press **Reset** momentarily (for <1 second) within 1 second. Nothing happens if the momentary press does not occur within 1 second.

Result

Reset All IP Settings mode:

- Sets the IP address back to factory default (192.168.254.251).
- Sets the subnet back to factory default (255.255.255.0).
- Sets the default gateway address to the factory default (0.0.0.0).
- Sets all other IP settings, addresses, and domain and host names back to factory default.
- Turns DHCP off.

The screen goes black with a message **Project Not Running**. The FPC 6000 cannot be accessed from the front panel and the IP address has been changed.

Press the rear panel **Menu** button (see [figure 5, C](#) on page 10). Use the **Network** page of the **Setup** menu (see page 14) to reset the IP address.

Once the IP address has been reset, use a PC to open the FPC 6000 web page and install new firmware (see [Updating Firmware Using the Touchpanel Web Page](#) on page 21). Once the new firmware is installed, the FPC 6000 functions normally.

Reset to Factory Defaults

This mode resets all IP settings and touchpanel settings to factory defaults and removes all configurations. It allows you to start over with configuration and uploading.

Activation

To reset the unit to all factory default settings:

1. Hold down the **Reset** button for about 9 seconds until the Power LED blinks three times (once at 3 seconds, again at 6 seconds, and again at 9 seconds).
2. Release and press **Reset** momentarily (for <1 second) within 1 second. Nothing happens if the momentary press does not occur within 1 second.

Result

Reset to Factory Defaults mode performs a complete reset to factory defaults (except the firmware):

- Does everything Reset All IP Settings mode does.
- Removes touchpanel user interface layout and configurations.
- Resets all touchpanel settings to factory default.
- Resets passwords to default

NOTES:

- The factory configured passwords for all accounts on this device have been set to the device serial number. Passwords are case sensitive.
- If the device is reset to default settings, the password is the default password configuration. The default password is **extron**.
- To change the password, you must use the Extron Toolbelt utility (see the *Toolbelt Help File*). Talk to your Extron rep about obtaining a license for Toolbelt.

The screen goes black with a message **Project Not Running**. The FPC 6000 cannot be accessed from the front panel and the IP address has been changed.

Press the rear panel **Menu** button (see [figure 5](#),  on page 10). Use the **Network** page of the **Setup** menu (see page 14) to reset the IP address.

Once the IP address has been reset, use a PC to open the FPC 6000 web page and install new firmware (see [Updating Firmware Using the Touchpanel Web Page](#) on page 21). Once the new firmware is installed, the FPC 6000 functions normally.

Extron Warranty

Extron Electronics warrants this product against defects in materials and workmanship for a period of three years from the date of purchase. In the event of malfunction during the warranty period attributable directly to faulty workmanship and/or materials, Extron Electronics will, at its option, repair or replace said products or components, to whatever extent it shall deem necessary to restore said product to proper operating condition, provided that it is returned within the warranty period, with proof of purchase and description of malfunction to:

USA, Canada, South America, and Central America:

Extron Electronics
1230 South Lewis Street
Anaheim, CA 92805
U.S.A.

Asia:

Extron Electronics Asia Pte. Ltd.
135 Joo Seng Road, #04-01
PM Industrial Bldg.
Singapore 368363
Singapore

Japan:

Extron Electronics, Japan
Kyodo Building, 16 Ichibancho
Chiyoda-ku, Tokyo 102-0082
Japan

Europe:

Extron Europe
Hanzeboulevard 10
3825 PH Amersfoort
The Netherlands

China:

Extron China
686 Ronghua Road
Songjiang District
Shanghai 201611
China

Middle East:

Extron Middle East
Dubai Airport Free Zone
F13, PO Box 293666
Dubai, United Arab Emirates

Africa:

Extron South Africa
South Tower
160 Jan Smuts Avenue
Rosebank 2196, South Africa

This Limited Warranty does not apply if the fault has been caused by misuse, improper handling care, electrical or mechanical abuse, abnormal operating conditions, or if modifications were made to the product that were not authorized by Extron.

NOTE: If a product is defective, please call Extron and ask for an Application Engineer to receive an RA (Return Authorization) number. This will begin the repair process.

USA: 714.491.1500 or 800.633.9876

Asia: 65.6383.4400

Europe: 31.33.453.4040 or 800.3987.6673

Japan: 81.3.3511.7655

Africa: 27.11.447.6162

Middle East: 971.4.299.1800

Units must be returned insured, with shipping charges prepaid. If not insured, you assume the risk of loss or damage during shipment. Returned units must include the serial number and a description of the problem, as well as the name of the person to contact in case there are any questions.

Extron Electronics makes no further warranties either expressed or implied with respect to the product and its quality, performance, merchantability, or fitness for any particular use. In no event will Extron Electronics be liable for direct, indirect, or consequential damages resulting from any defect in this product even if Extron Electronics has been advised of such damage.

Please note that laws vary from state to state and country to country, and that some provisions of this warranty may not apply to you.